

AAZA



HIGH PRESSURE WITH STRAIGHT IMPELLER

MANUFACTURING FEATURES:

- Fan made of Fe360 sheet. The fan paint finish is based on a Qualicoat polyester powder coating stoved at 200°C, with an average film thickness of 70 microns. Average heat resistance of coating is 180°C with peaks of 200°C.
- Fully welded housing.
- High efficiency simple inlet straight blade impeller made of Fe360 sheet statically and dynamically balanced. Impellers are painted with polyester primer that resists temperatures up to 300°C.
- Standard asynchronous squirrel-cage motor with IP-55 protection and class F insulation. Manufactured with standard voltages: 230/400V 50Hz in three phase motors up to 4kW and 400/690V 50Hz for higher powers.
- Standard orientation LG270.
- It allows adjusting the orientation locally from models 400 to 630. Models sizes from 710 to 1000 size the orientation is fixed.

APPLICATIONS:

- Designed for inline installation, they are suitable for:
- Industrial applications, extraction or injection of air.
 - Cooling of machines and parts.
 - Clean and dusty air transport.
 - Exhaust after filters, separators and cyclones.
 - Pneumatic transport.
 - Maximum working temperature: carried air: 130°C, ambient: 60°C.

UNDER REQUEST

- Fans for 60Hz and special voltages.
- 2 speed motor.
- C4 or C5 coating painting
- Hot dip galvanized
- Special steel (Cor-Ten A, Hardox...)
- Inox 304 (normal or electropolished finish)
- Inox 316 (normal or electropolished finish)
- Cooling wheel
- Anticaloric paint
- Reinforced housing
- Fully welded housing (waterproof)
- Insulated housing
- Split casing (for big sizes)
- Inspection door to facilitate maintenance and cleaning
- Drain plug.
- Airtight axle
- Frontal foot
- Double suction flange
- Available in non-sparking air passage and standard motor.
- Other brands of motors.
- Orientation: RD0, RD45, RD90, RD135, RD180, RD225, RD270, RD315, LG0, LG45, LG90, LG135, LG180. LG225, LG315.

Accessories



AB AC AVR AVS

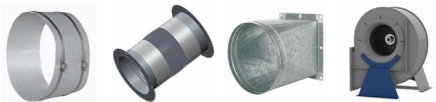

BA-400 BAD EI FS



INT JE 45 RA RI



SFC

Technical data

Three-phase motor / 2 poles

Code	Model	R.P.M.	Rated I. (A) 400V	Rated power kW	Max. Airflow w m3/h	Sound db (A)**	Weight t	Connect. diagram
502904017	AAZA 400 T2 0,75kW	2800	1,58	0,75	440	71	39	1
502904018	AAZA 400 T2 1,1kW	2800	2,33	1,1	480	71	39	1
502904518	AAZA 450 T2 1,1kW	2800	2,33	1,1	550	73	42	1
502904519	AAZA 450 T2 1,5kW	2865	3,14	1,5	660	74	45	1
502905027	AAZA 500 T2 2,2kW	2840	4,58	2,2	870	76	55	1
502905029	AAZA 500 T2 3kW	2880	5,92	3	870	77	63	1
502905629	AAZA 560 T2 3kW	2880	5,92	3	940	79	89	1
502905632	AAZA 560 T2 4kW	2880	7,63	4	1.230	80	100	1
502906334	AAZA 630 T2 5,5kW	2910	10,6	5,5	1.450	84	134	1
502906336	AAZA 630 T2 7,5kW	2910	14,1	7,5	1.810	85	134	1
502907136	AAZA 710 T2 7,5kW	2910	14,1	7,5	1.230	87	202	1
502907121	AAZA 710 T2 11kW	2940	20,8	11	2.530	88	218	1
502908024	AAZA 800 T2 15kW	2935	27,4	15	2.530	92	262	1
502908026	AAZA 800 T2 18,5kW	2940	34,4	18,5	2.890	92	277	1

Three-phase motor / 4 poles

Code	Model	R.P.M.	Rated I. (A) 400V	Rated power kW	Max. Airflow w m3/h	Sound db (A)**	Weight t	Connect. diagram
502908056	AAZA 800 T4 3kW	1420	6,17	3	1.810	76	195	1
502908059	AAZA 800 T4 4kW	1440	8,32	4	1.810	76	202	1
502909061	AAZA 900 T4 5,5kW	1460	10,5	5,5	2.530	78	307	1
502909063	AAZA 900 T4 7,5kW	1455	14,1	7,5	2.890	79	341	1
502910063	AAZA 1000 T4 7,5kW	1455	14,1	7,5	3.250	80	370	1
502910049	AAZA 1000 T4 11kW	1455	21,2	11	4.010	82	410	1

Notes:

** Total sound pressure level at the point of maximum flow measured in dB(A) in the suction measured in free field at a distance of 6m from the source

Dimensions

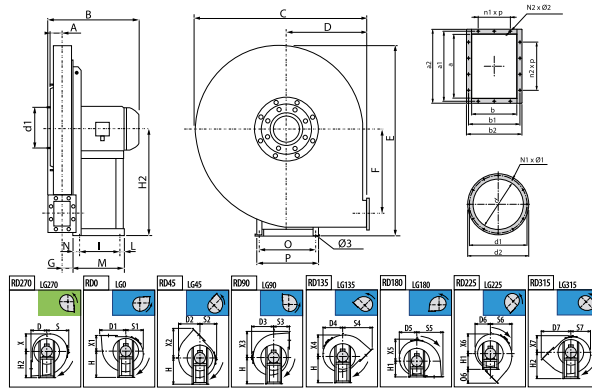

Model	A	B	C	D	D1	D2	D3	D4	D5
AAZA 400 T2 0,75kW	42	336	620	280	351	314	340	302	282
AAZA 400 T2 1,1kW	42	336	620	280	351	314	340	302	282
AAZA 450 T2 1,1kW	46	344	675	300	388	350	375	335	313
AAZA 450 T2 1,5kW	46	391	675	300	388	350	375	335	313
AAZA 500 T2 2,2kW	52	400	745	335	431	386	410	370	345
AAZA 500 T2 3kW	52	431	745	335	431	386	410	370	345
AAZA 560 T2 3kW	59	442	835	375	483	438	460	418	391
AAZA 560 T2 4kW	59	463	835	375	483	438	460	418	391
AAZA 630 T2 5,5kW	65	518	940	425	544	493	515	472	441
AAZA 630 T2 7,5kW	65	518	940	425	544	493	515	472	441
AAZA 710 T2 7,5kW	70	531	1045	475	606	547	570	522	492
AAZA 710 T2 11kW	70	636	1045	475	606	547	570	522	492
AAZA 800 T2 15kW	78	650	1170	530	679	622	640	592	554
AAZA 800 T2 18,5kW	78	650	1170	530	679	622	640	592	554
AAZA 800 T4 3kW	78	484	1170	530	679	622	640	592	554
AAZA 800 T4 4kW	78	505	1170	530	679	622	640	592	554
AAZA 900 T4 5,5kW	86	562	1315	600	759	696	715	668	628
AAZA 900 T4 7,5kW	86	562	1315	600	759	696	715	668	628
AAZA 1000 T4 7,5kW	95	581	1460	670	841	775	790	735	691
AAZA 1000 T4 11kW	95	686	1460	670	841	775	790	735	691

Model	D6	D7	E	F	G	H	H1	H2	I
AAZA 400 T2 0,75kW	293	445	657	273	38	375	375	375	121
AAZA 400 T2 1,1kW	293	445	657	273	38	375	375	375	121
AAZA 450 T2 1,1kW	319	486	713	305	42	400	400	400	121

Model	D6	D7	E	F	G	H	H1	H2	I
AAZA 450 T2 1,5kW	319	486	713	305	42	400	400	400	133
AAZA 500 T2 2,2kW	350	541	795	342	47	450	450	450	133
AAZA 500 T2 3kW	350	541	795	342	47	450	450	450	197
AAZA 560 T2 3kW	392	606	891	387	53	500	500	500	197
AAZA 560 T2 4kW	392	606	891	387	53	500	500	500	197
AAZA 630 T2 5,5kW	438	688	1001	436	58	560	560	560	237
AAZA 630 T2 7,5kW	438	688	1001	436	58	560	560	560	237
AAZA 710 T2 7,5kW	489	764	1122	488	65	630	630	630	237
AAZA 710 T2 11kW	489	764	1122	488	65	630	630	630	337
AAZA 800 T2 15kW	545	854	1264	551	72	710	710	710	337
AAZA 800 T2 18,5kW	545	854	1264	551	72	710	710	710	337
AAZA 800 T4 3kW	545	854	1264	551	72	710	710	710	197
AAZA 800 T4 4kW	545	854	1264	551	72	710	710	710	197
AAZA 900 T4 5,5kW	617	961	1428	620	80	800	800	800	237
AAZA 900 T4 7,5kW	617	961	1428	620	80	800	800	800	237
AAZA 1000 T4 7,5kW	670	1072	1591	690	90	900	900	900	237
AAZA 1000 T4 11kW	670	1072	1591	690	90	900	900	900	337

Model	L	M	N	N1XØ1	N2XØ2	O	O6	P	S
AAZA 400 T2 0,75kW	45	211	45	Nº4 M6x20	4X10	203	165	225	340
AAZA 400 T2 1,1kW	45	211	45	Nº4 M6x20	4x10	203	165	225	340
AAZA 450 T2 1,1kW	45	211	45	Nº8 M6x20	4x10	203	186	225	375
AAZA 450 T2 1,5kW	58	246	55	Nº8 M6x20	4x10	234	186	260	375
AAZA 500 T2 2,2kW	58	246	55	Nº8 M6x20	4x10	234	206	260	410
AAZA 500 T2 3kW	49	276	30	Nº8 M6x20	4x10	289	206	324	410
AAZA 560 T2 3kW	49	276	30	Nº8 M6x20	6x10	289	231	324	460
AAZA 560 T2 4kW	49	276	30	Nº8 M6x20	6x10	289	231	324	460
AAZA 630 T2 5,5kW	59	336	40	Nº8 M6x20	6x12	337	263	372	515
AAZA 630 T2 7,5kW	59	336	40	Nº8 M6x20	6x12	337	263	372	515
AAZA 710 T2 7,5kW	59	336	40	Nº8 M8x25	6x12	337	289	372	570
AAZA 710 T2 11kW	49	436	50	Nº8 M8x25	6x12	395	289	440	570

Model	L	M	N	N1XØ1	N2XØ2	O	O6	P	S
AAZA 800 T2 15kW	49	436	50	Nº8 M8x25	6x12	395	324	440	640
AAZA 800 T2 18,5kW	49	436	50	Nº8 M8x25	6x12	395	324	440	640
AAZA 800 T4 3kW	49	276	30	Nº8 M8x25	6x12	289	324	324	640
AAZA 800 T4 4kW	49	276	30	Nº8 M8x25	6x12	289	324	324	640
AAZA 900 T4 5,5kW	59	336	40	Nº8 M8x25	8x12	337	361	372	715
AAZA 900 T4 7,5kW	59	336	40	Nº8 M8x25	8x12	337	361	372	715
AAZA 1000 T4 7,5kW	59	336	40	Nº8 M8x25	8x12	337	172	372	790
AAZA 1000 T4 11kW	49	436	50	Nº8 M8x25	8x12	395	172	440	790

Model	S1	S2	S3	S4	S5	S6	S7	X	X1
AAZA 400 T2 0,75kW	282	293	280	445	351	314	302	282	280
AAZA 400 T2 1,1kW	282	293	280	445	351	314	302	282	280
AAZA 450 T2 1,1kW	313	319	300	486	388	350	335	313	300
AAZA 450 T2 1,5kW	313	319	300	486	388	350	335	313	300
AAZA 500 T2 2,2kW	345	350	335	541	431	386	370	345	335
AAZA 500 T2 3kW	345	350	335	541	431	386	370	345	335
AAZA 560 T2 3kW	391	392	375	606	483	438	418	391	375
AAZA 560 T2 4kW	391	392	375	606	483	438	418	391	375
AAZA 630 T2 5,5kW	441	438	425	688	544	493	472	441	425
AAZA 630 T2 7,5kW	441	438	425	688	544	493	472	441	425
AAZA 710 T2 7,5kW	492	489	475	764	606	547	522	492	475
AAZA 710 T2 11kW	492	489	475	764	606	547	522	492	475
AAZA 800 T2 15kW	554	545	530	854	679	622	592	554	530
AAZA 800 T2 18,5kW	554	545	530	854	679	622	592	554	530
AAZA 800 T4 3kW	554	545	530	854	679	622	592	554	530
AAZA 800 T4 4kW	554	545	530	854	679	622	592	554	530
AAZA 900 T4 5,5kW	628	617	600	961	759	696	668	628	600
AAZA 900 T4 7,5kW	628	617	600	961	759	696	668	628	600
AAZA 1000 T4 7,5kW	691	670	670	1072	841	775	735	691	670
AAZA 1000 T4 11kW	691	670	670	1072	841	775	735	691	670

Model	X2	X3	X4	X5	X6	X7	a	a1	a2
AAZA 400 T2 0,75kW	445	351	314	340	302	293	95	129	155
AAZA 400 T2 1,1kW	445	351	314	340	302	293	95	129	155
AAZA 450 T2 1,1kW	486	388	350	375	335	319	105	139	165

Model	X2	X3	X4	X5	X6	X7	a	a1	a2
AAZA 450 T2 1,5kW	486	388	350	375	335	319	105	139	165
AAZA 500 T2 2,2kW	541	431	386	410	370	350	117	151	177
AAZA 500 T2 3kW	541	431	386	410	370	350	117	151	177
AAZA 560 T2 3kW	606	483	438	460	418	392	131	165	191
AAZA 560 T2 4kW	606	483	438	460	418	392	131	165	191
AAZA 630 T2 5,5kW	688	544	493	515	472	438	146	182	216
AAZA 630 T2 7,5kW	688	544	493	515	472	438	146	182	216
AAZA 710 T2 7,5kW	764	606	547	570	522	489	166	200	236
AAZA 710 T2 11kW	764	606	547	570	522	489	166	200	236
AAZA 800 T2 15kW	854	679	622	640	592	545	185	219	255
AAZA 800 T2 18,5kW	854	679	622	640	592	545	185	219	255
AAZA 800 T4 3kW	854	679	622	640	592	545	185	219	255
AAZA 800 T4 4kW	854	679	622	640	592	545	185	219	255
AAZA 900 T4 5,5kW	961	759	696	715	668	617	207	241	277
AAZA 900 T4 7,5kW	961	759	696	715	668	617	207	241	277
AAZA 1000 T4 7,5kW	1072	841	775	790	735	670	231	265	301
AAZA 1000 T4 11kW	1072	841	775	790	735	670	231	265	301

Model	b	b1	b2	d	d1	d2	n1xp	n2xp	Ø3
AAZA 400 T2 0,75kW	68	102	128	130	165	190	-	-	10
AAZA 400 T2 1,1kW	68	102	128	130	165	190	-	-	10
AAZA 450 T2 1,1kW	76	110	136	145	182	215	-	-	10
AAZA 450 T2 1,5kW	76	110	136	145	182	215	-	-	10
AAZA 500 T2 2,2kW	85	119	145	165	200	235	-	-	10
AAZA 500 T2 3kW	85	119	145	165	200	235	-	-	12
AAZA 560 T2 3kW	95	129	155	185	219	250	-	1x100	12
AAZA 560 T2 4kW	95	129	155	185	219	250	-	1x100	12
AAZA 630 T2 5,5kW	105	139	175	205	241	275	-	1x112	12
AAZA 630 T2 7,5kW	105	139	175	205	241	275	-	1x112	12
AAZA 710 T2 7,5kW	117	151	187	228	265	298	-	1x112	12
AAZA 710 T2 11kW	117	151	187	228	265	298	-	1x112	14
AAZA 800 T2 15kW	131	165	201	255	292	325	-	1x112	14
AAZA 800 T2 18,5kW	131	165	201	255	292	325	-	1x112	14
AAZA 800 T4 3kW	131	165	201	255	292	325	-	1x112	12
AAZA 800 T4 4kW	131	165	201	255	292	325	-	1x112	12
AAZA 900 T4 5,5kW	148	182	218	285	332	365	1x112	1x112	12
AAZA 900 T4 7,5kW	148	182	218	285	332	365	1x112	1x112	12
AAZA 1000 T4 7,5kW	166	200	236	320	366	400	1x112	1x112	12
AAZA 1000 T4 11kW	166	200	236	320	366	400	1x112	1x112	14

Wiring diagram

DIAGRAM Nº 1

230/400V

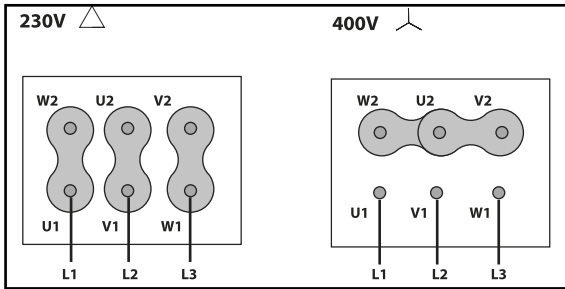

400/690V

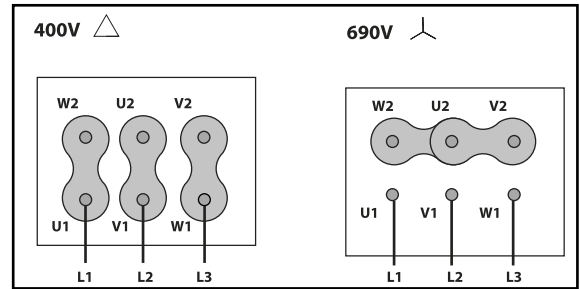

CHARACTERISTIC CURVE

1	AAZA 400 T2 0,75kW	2	AAZA 400 T2 1,1kW	3	AAZA 450 T2 1,1kW	4	AAZA 450 T2 1,5kW
5	AAZA 500 T2 2,2kW	6	AAZA 500 T2 3kW	7	AAZA 560 T2 3kW		

AIR FLOW - PRESSURE

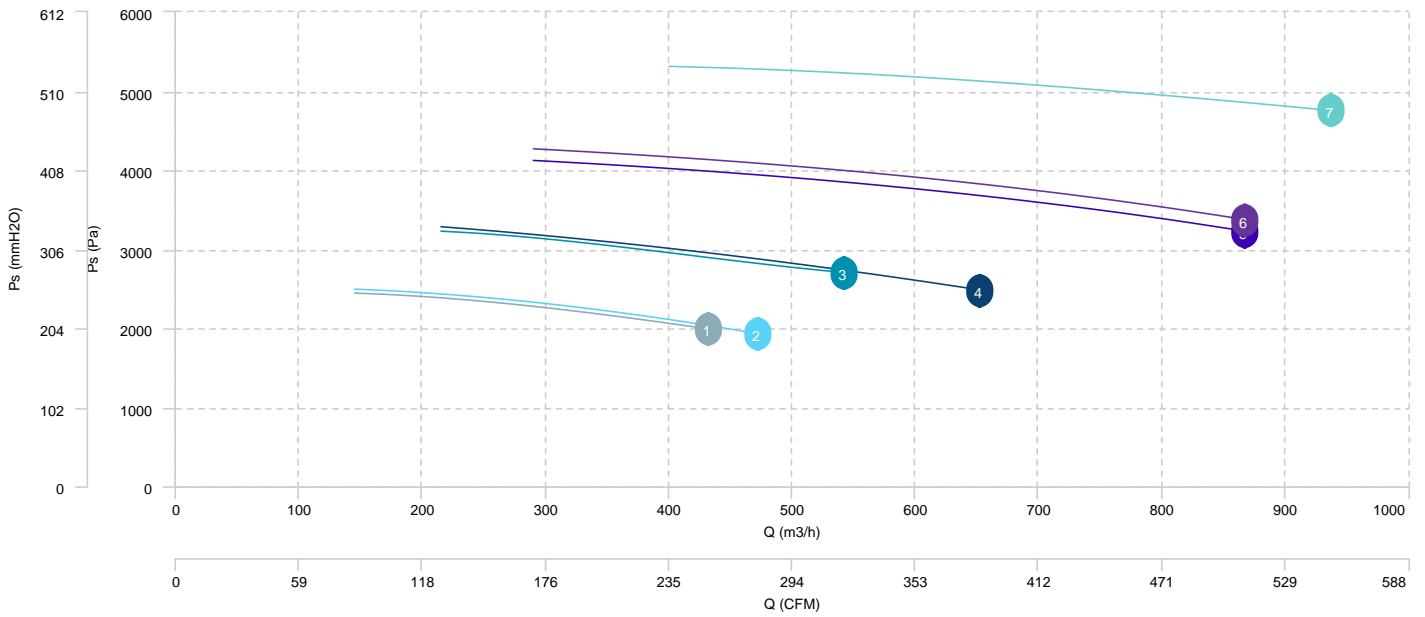

AIR FLOW - ABSORBED POWER

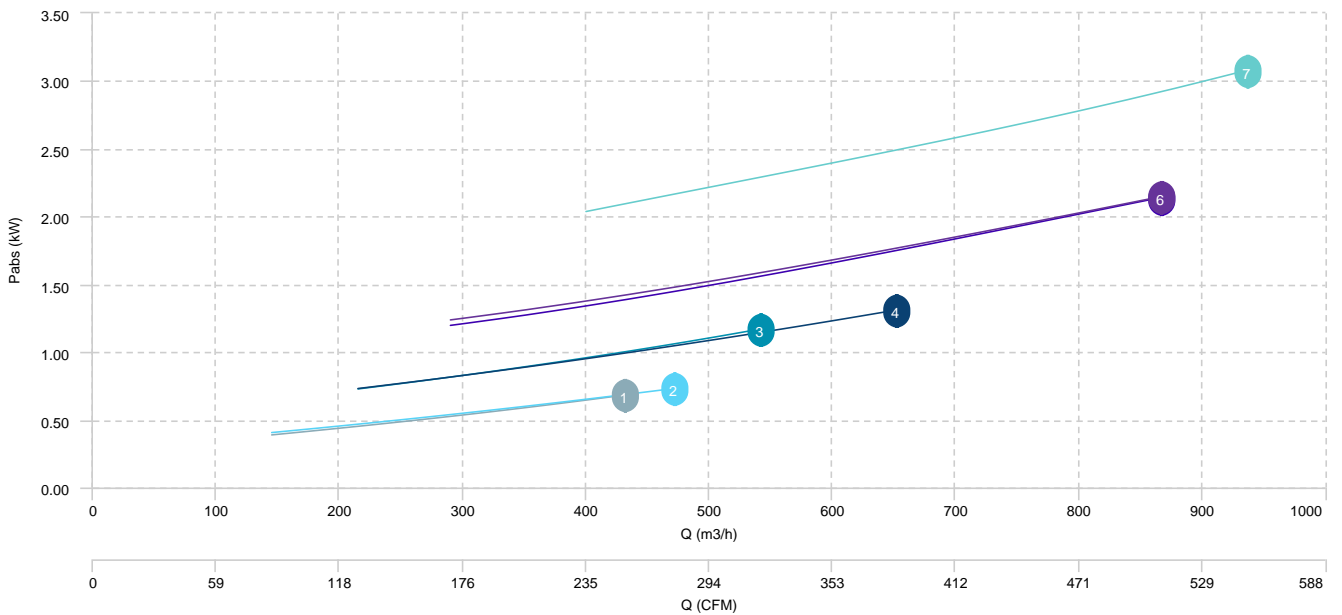

1	AAZA 560 T2 4kW	2	AAZA 630 T2 5,5kW	3	AAZA 630 T2 7,5kW	4	AAZA 710 T2 7,5kW
5	AAZA 710 T2 11kW	6	AAZA 800 T2 15kW	7	AAZA 800 T2 18,5kW		

AIR FLOW - PRESSURE

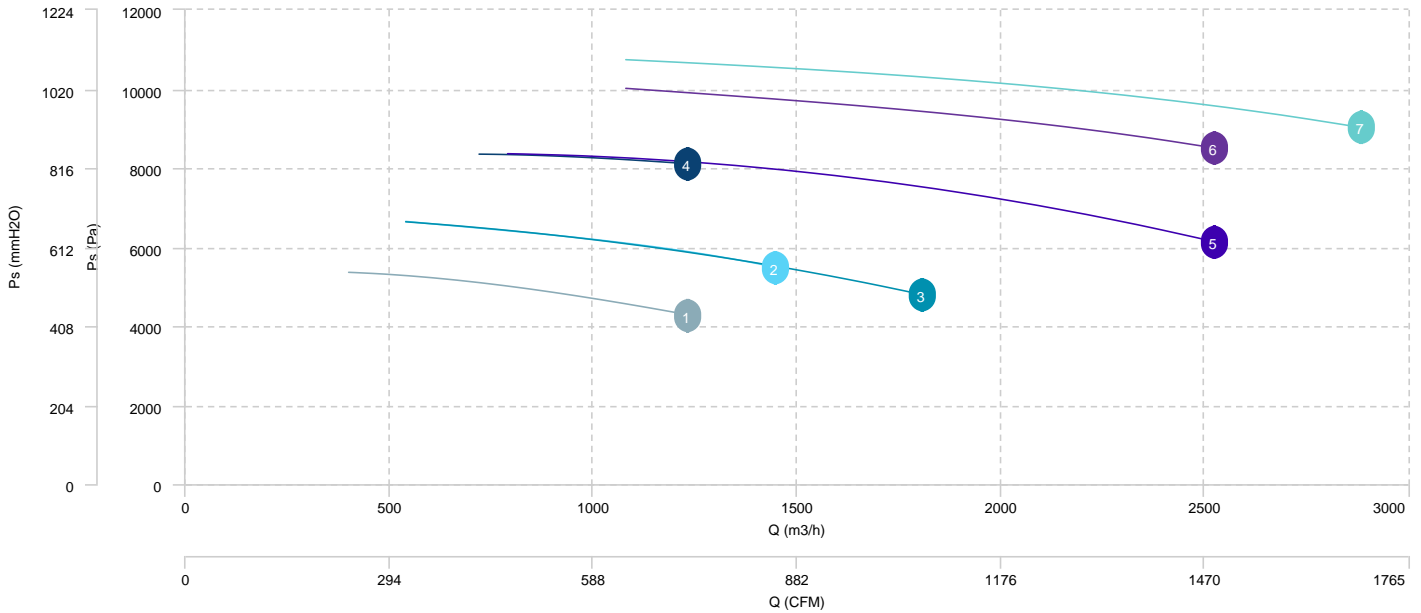

AIR FLOW - ABSORBED POWER

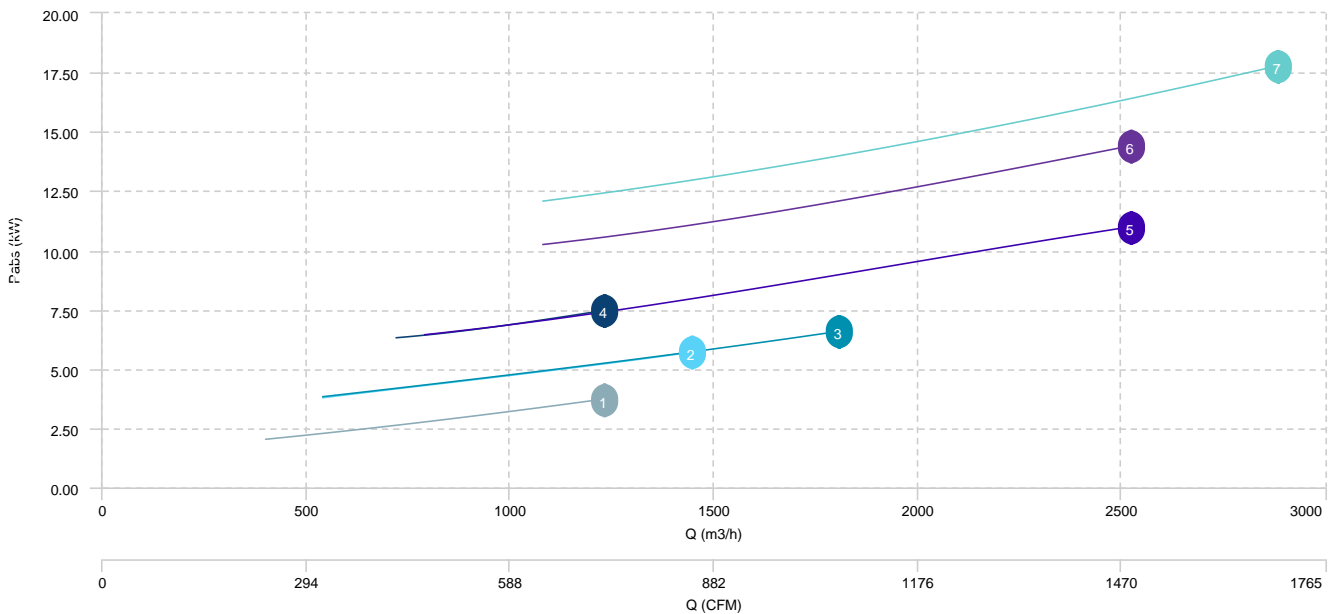

1	AAZA 800 T4 3kW	2	AAZA 800 T4 4kW	3	AAZA 900 T4 5,5kW	4	AAZA 900 T4 7,5kW
5	AAZA 1000 T4 7,5kW	6	AAZA 1000 T4 11kW				

AIR FLOW - PRESSURE

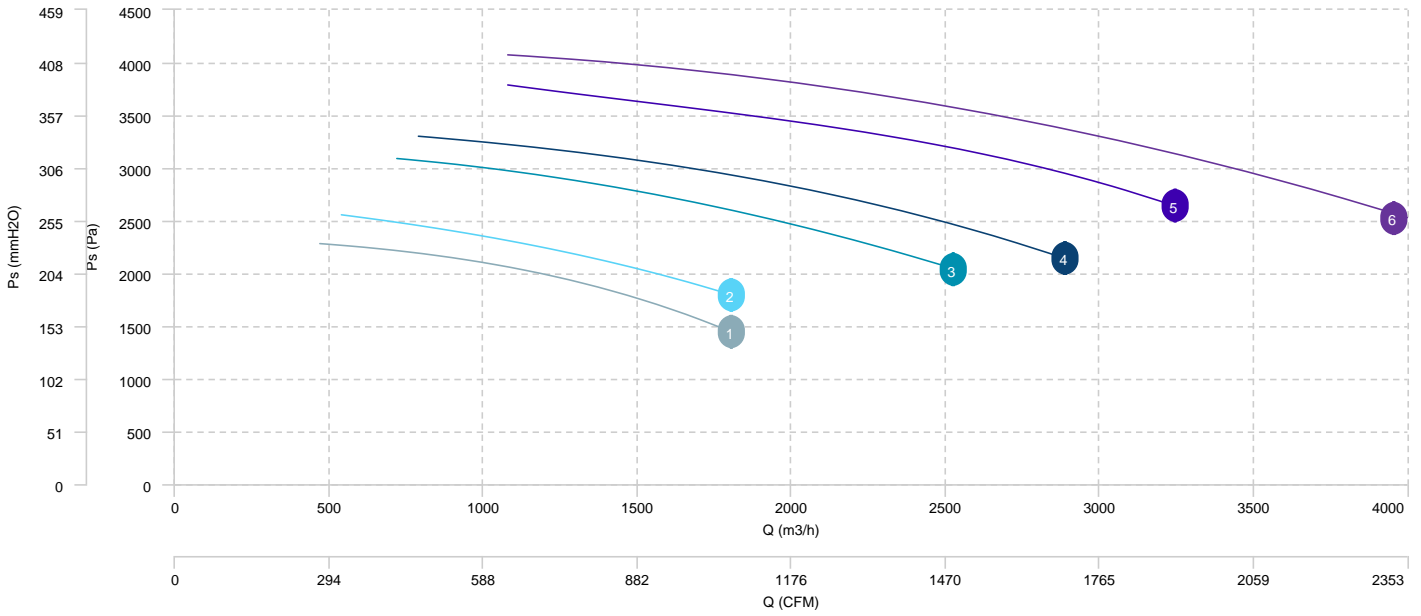

AIR FLOW - ABSORBED POWER

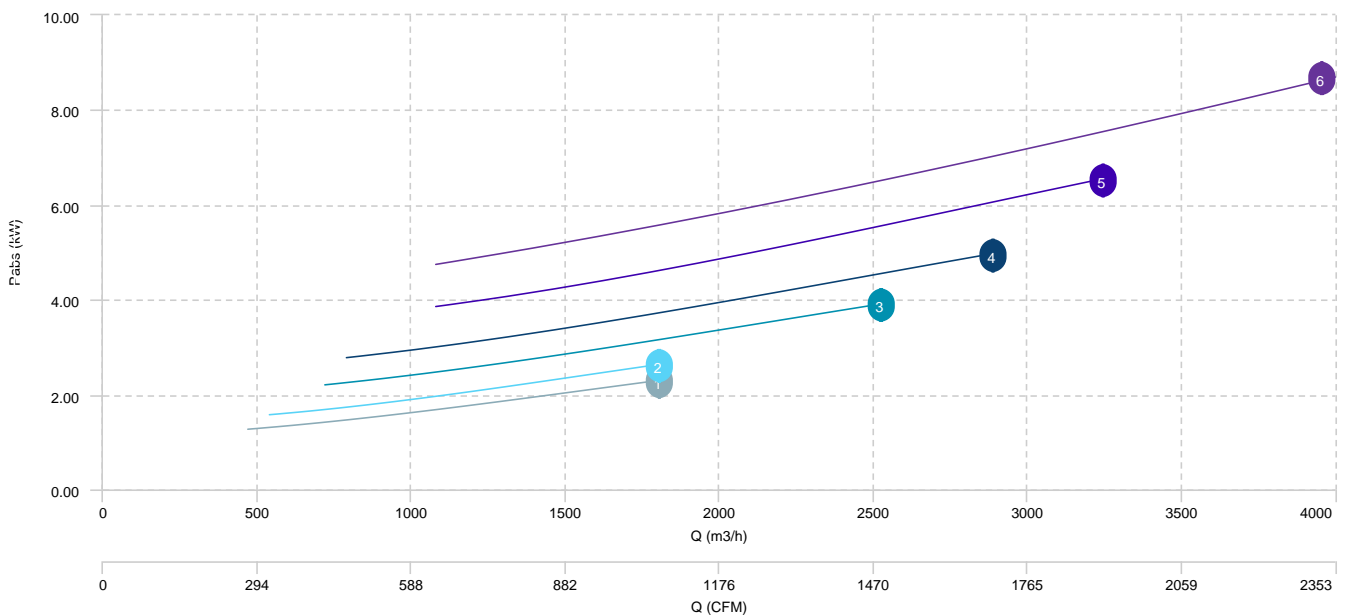

Sound data

Sound / 2 poles

Sound power Lw dB (A)										
Model		63 Hz	125 Hz	250 Hz	500 Hz	1000 Hz	2000 Hz	4000 Hz	8000 Hz	Total
AAZA 400 T2 0,75kW	Inlet	59	75	90	90	91	88	86	76	97
AAZA 400 T2 1,1kW	Inlet	60	76	91	91	92	89	86	77	97
AAZA 450 T2 1,1kW	Inlet	62	78	93	93	94	91	88	79	99
AAZA 450 T2 1,5kW	Inlet	62	78	93	93	94	91	89	79	100
AAZA 500 T2 2,2kW	Inlet	65	81	96	96	97	94	92	82	102
AAZA 500 T2 3kW	Inlet	65	81	96	96	97	94	92	82	103
AAZA 560 T2 3kW	Inlet	68	84	99	99	100	97	94	85	105
AAZA 560 T2 4kW	Inlet	68	84	99	99	100	97	95	85	106
AAZA 630 T2 5,5kW	Inlet	72	88	103	103	104	101	99	89	110
AAZA 630 T2 7,5kW	Inlet	73	89	104	104	105	102	100	90	111
AAZA 710 T2 7,5kW	Inlet	75	91	107	107	108	104	102	93	113
AAZA 710 T2 11kW	Inlet	77	93	108	108	109	106	103	94	114
AAZA 800 T2 15kW	Inlet	80	96	111	111	112	109	107	97	118
AAZA 800 T2 18,5kW	Inlet	81	97	112	112	113	110	107	98	118

Sound / 4 poles

Sound power Lw dB (A)										
Model		63 Hz	125 Hz	250 Hz	500 Hz	1000 Hz	2000 Hz	4000 Hz	8000 Hz	Total
AAZA 800 T4 3kW	Inlet	64	80	95	95	96	93	91	81	102
AAZA 800 T4 4kW	Inlet	65	81	96	96	97	94	92	82	102
AAZA 900 T4 5,5kW	Inlet	67	83	98	98	99	96	94	84	104
AAZA 900 T4 7,5kW	Inlet	67	83	99	99	100	96	94	85	105
AAZA 1000 T4 7,5kW	Inlet	68	84	99	99	100	97	95	85	106
AAZA 1000 T4 11kW	Inlet	70	86	101	101	102	99	97	87	108