

BD 3V



DOUBLE INLET, 3 SPEED MOTOR

MANUFACTURING FEATURES:

- Galvanised steel sheet housing .
- Polyamide impeller reinforced with fibreglass in models 7/7, 9/9, 10/10 and 12/12. Galvanised steel sheet impeller for all range.
- Double inlet forward curved impeller.
- Supplied with mounting feet (included in price).
- Exclusive system Casals fixing motor and turbine fan by flexible arms silent blocks to avoid any vibration. Arms in compliance with ROHS regulations 2002/95 / EC (Restriction of Hazardous Substances in electrical and electronic equipment)
- Closed 3 speed motor specially designed Casals: extruded aluminum housing, all protected inside the terminal box on the motor IP 65 protection and motor with IP54 protection and Class F insulation standard voltages: 230V 50Hz
- Integrated thermal protector in the winding

Accessories



INT



INT 3V



MBI



RA



REG



RI



RM



S

APPLICATIONS:

Designed for assembly in equipment:

- Ventilation boxes and air handling units.
- Centrifugal heaters.
- Industrial and professional kitchen hoods.
- Maximum working temperature: 50°C.

UNDER REQUEST:

- Impellers made of galvanized sheet.
- MBI assembled.

* While stocks last

Technical data

3 SPEED MOTOR / 4 poles

Code	Model	R.P.M.	Rated I. (A) 230V	Rated power kW	Max. Airflow m3/h	Sound db (A)**	Weigh t	diagram
251100268	BD 7/7 M4 0,12kW 3V*	1126 / 1266 / 1360	L1=1,5 L2=0,9 L3=0,6	0,12	720 / 1.050 / 1.739	53	9	1
251270268	BD 9/7 M4 0,35kW 3V	1167 / 1260 / 1400	L1=3,2 L2=2,4 L3=1,6	0,35	1.070 / 1.740 / 2. 620	66	15	1
251220268	BD 9/9 M4 0,35kW 3V	1167 / 1260 / 1400	L1=3,2 L2=2,4 L3=1,6	0,35	1.200 / 1.900 / 2. 919,10	53	16	1
251340268	BD 10/8 M4 0,59kW 3V	1032 / 1216 / 1400	L1=4,96 L2=2,9 L3=2	0,59	1.130 / 1.620 / 3. 235	68	20	1
251320268	BD 10/10 M4 0,59kW 3V	1032 / 1216 / 1400	L1=4,96 L2=2,9 L3=2	0,59	1.130 / 1.638 / 3. 700	57	22	1

3 SPEED MOTOR / 6 poles

Code	Model	R.P.M.	Rated I. (A) 230V	Rated power kW	Max. Airflow m3/h	Sound db (A)**	Weigh t	diagram
251600268	BD 12/9 M6 0,79kW 3V*	749 / 812 / 860	L1=6,5 L2=4,1 L3=3	0,79	2.520 / 4.140 / 5. 954	63	26	1
251520268	BD 12/12 M6 0,79kW 3V*	749 / 812 / 860	L1=6,5 L2=4,1 L3=3	0,79	2.500 / 4.200 / 6. 230	62	27	1

Notes:

** Total sound pressure level at the point of maximum flow measured in dB(A) in the suction measured in free field at a distance of 6m from the source

Dimensions

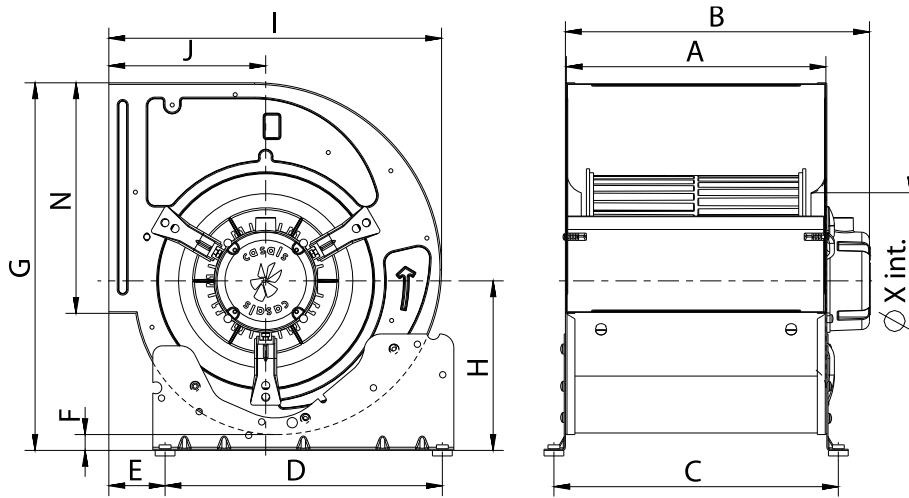

Model	A	B màx	C	D	E	F	G	H	I
BD 7/7 M4 0,12kW 3V*	230	302	259	245	48,5	9,5	337	150	313
BD 9/7 M4 0,35kW 3V	233	287	262	245	70	19	407	191	376
BD 9/9 M4 0,35kW 3V	301	354,5	330	245	70	19	407	191	376
BD 10/8 M4 0,59kW 3V	265	339	294	350	70,5	20	464	214	420
BD 10/10 M4 0,59kW 3V	329	384	359	350	70,5	20	464	214	420
BD 12/9 M6 0,79kW 3V*	310	389	339	350	77	17	536	244	490
BD 12/12 M6 0,79kW 3V*	396	450	425	350	77	17	536	244	490

Model	J	N	X
BD 7/7 M4 0,12kW 3V*	153	208	158
BD 9/7 M4 0,35kW 3V	184	260	202
BD 9/9 M4 0,35kW 3V	184	260	202
BD 10/8 M4 0,59kW 3V	198	291	220
BD 10/10 M4 0,59kW 3V	198	291	220
BD 12/9 M6 0,79kW 3V*	230	343,5	260
BD 12/12 M6 0,79kW 3V*	230	343,5	260

Wiring diagram

DIAGRAM N° 1

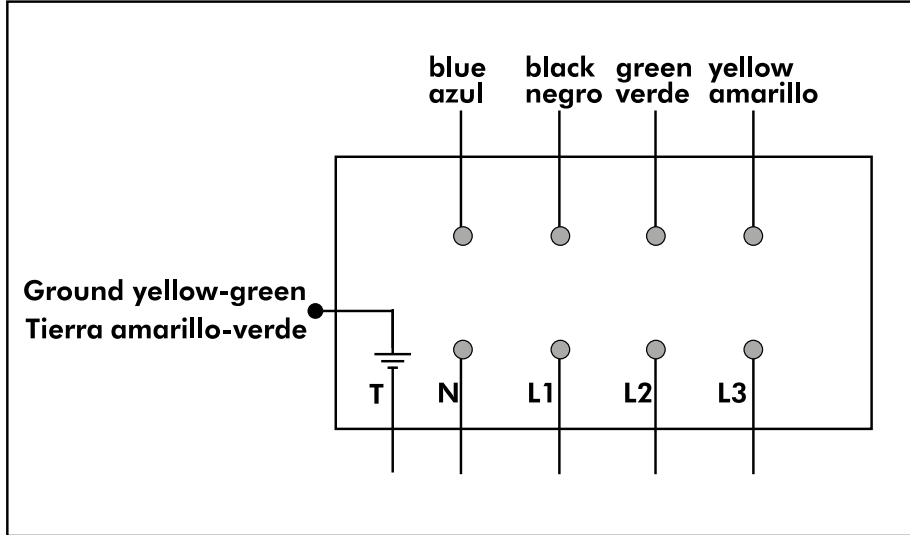

CHARACTERISTIC CURVE

- 1 BD 7/7 M4 0,12kW 3V*
- 2 BD 9/7 M4 0,35kW 3V
- 3 BD 9/9 M4 0,35kW 3V
- 4 BD 10/8 M4 0,59kW 3V
- 5 BD 10/10 M4 0,59kW 3V

AIR FLOW - PRESSURE

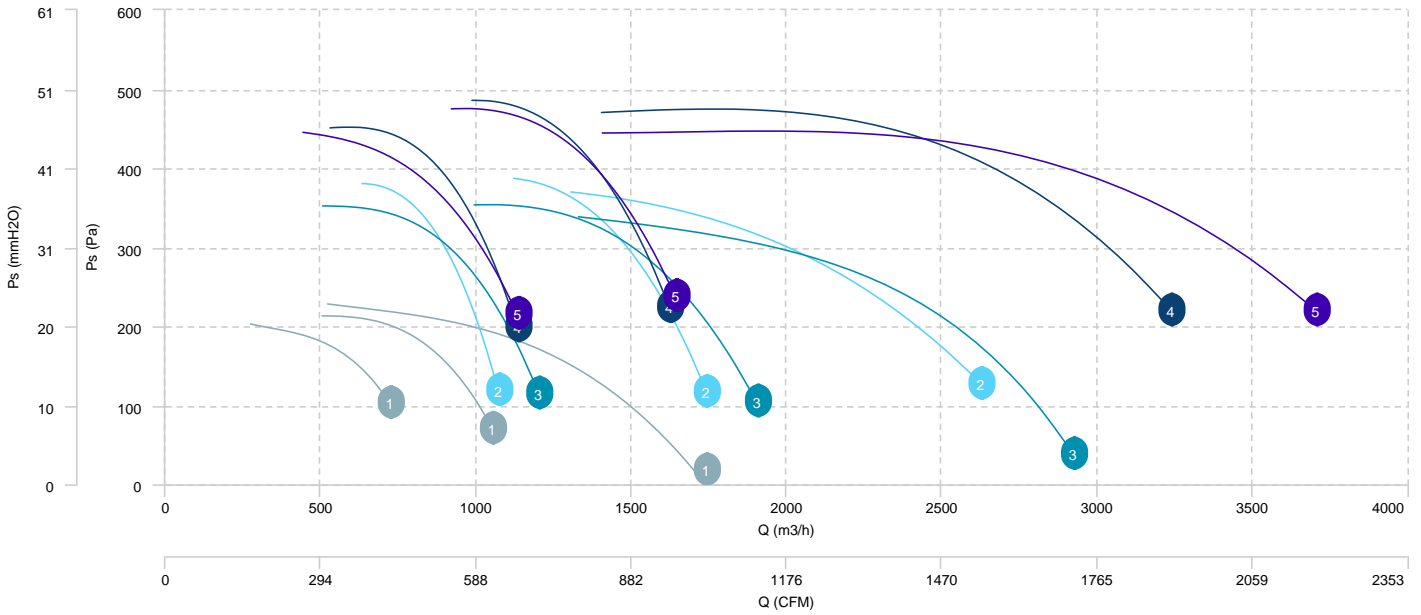

AIR FLOW - ABSORBED POWER

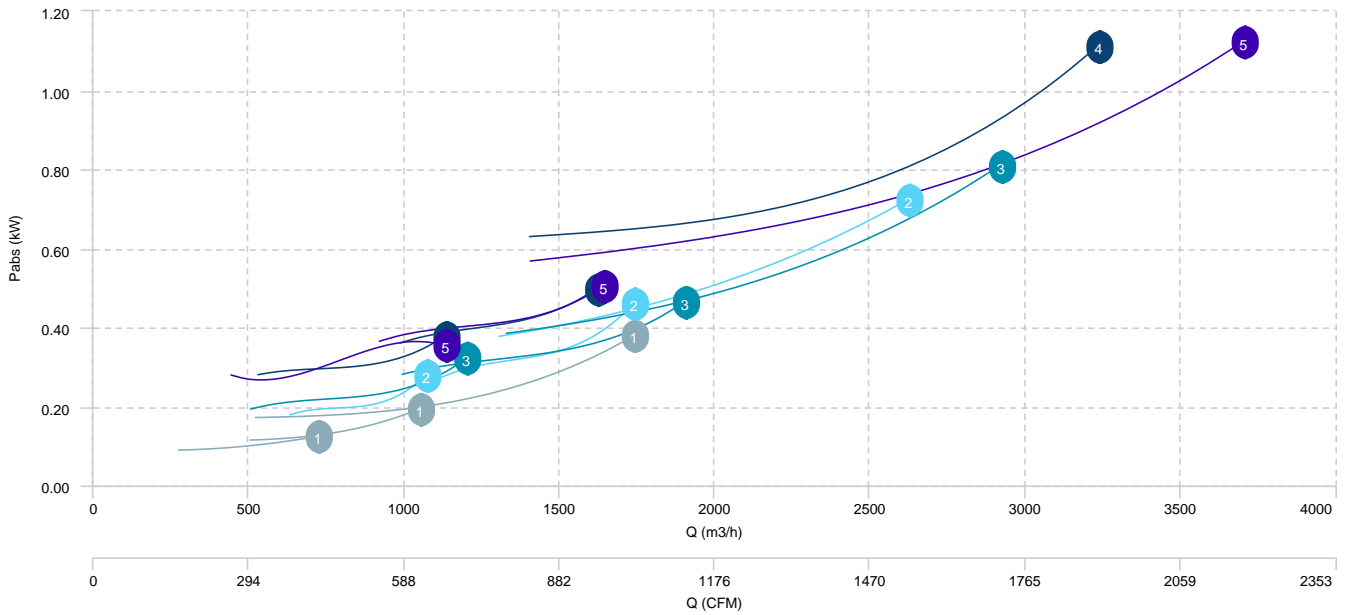

1 BD 12/9 M6 0,79kW 3V*

2 BD 12/12 M6 0,79kW 3V*

AIR FLOW - PRESSURE

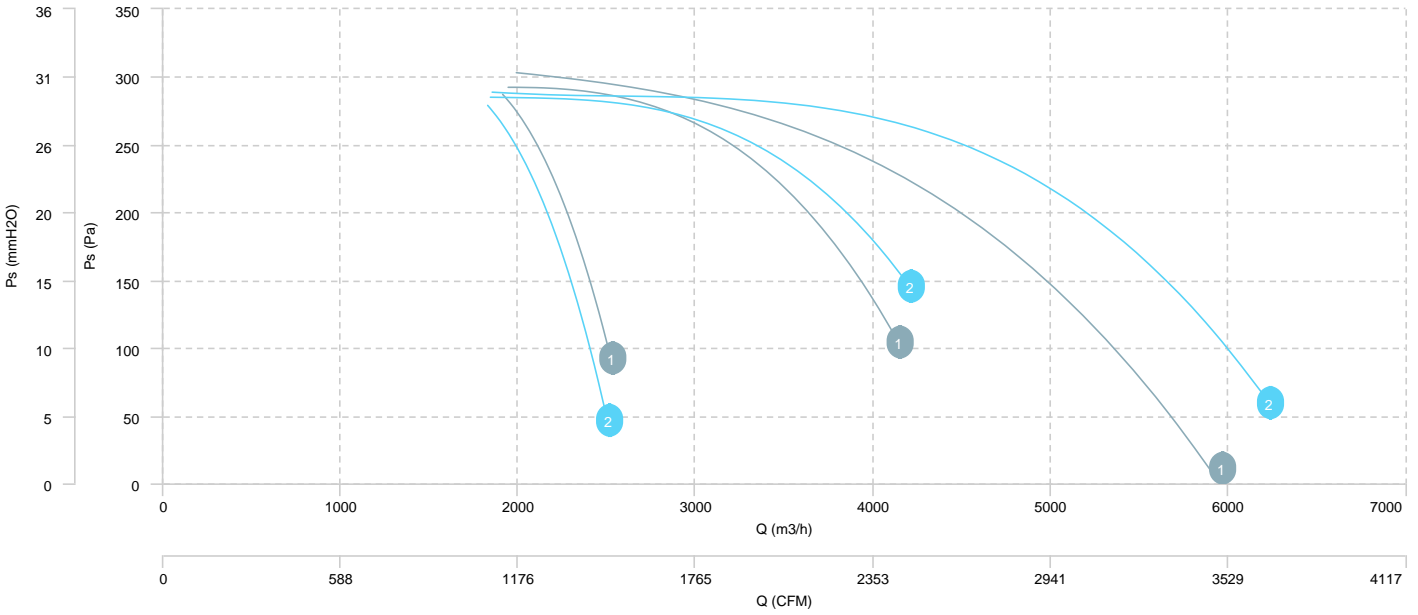

AIR FLOW - ABSORBED POWER

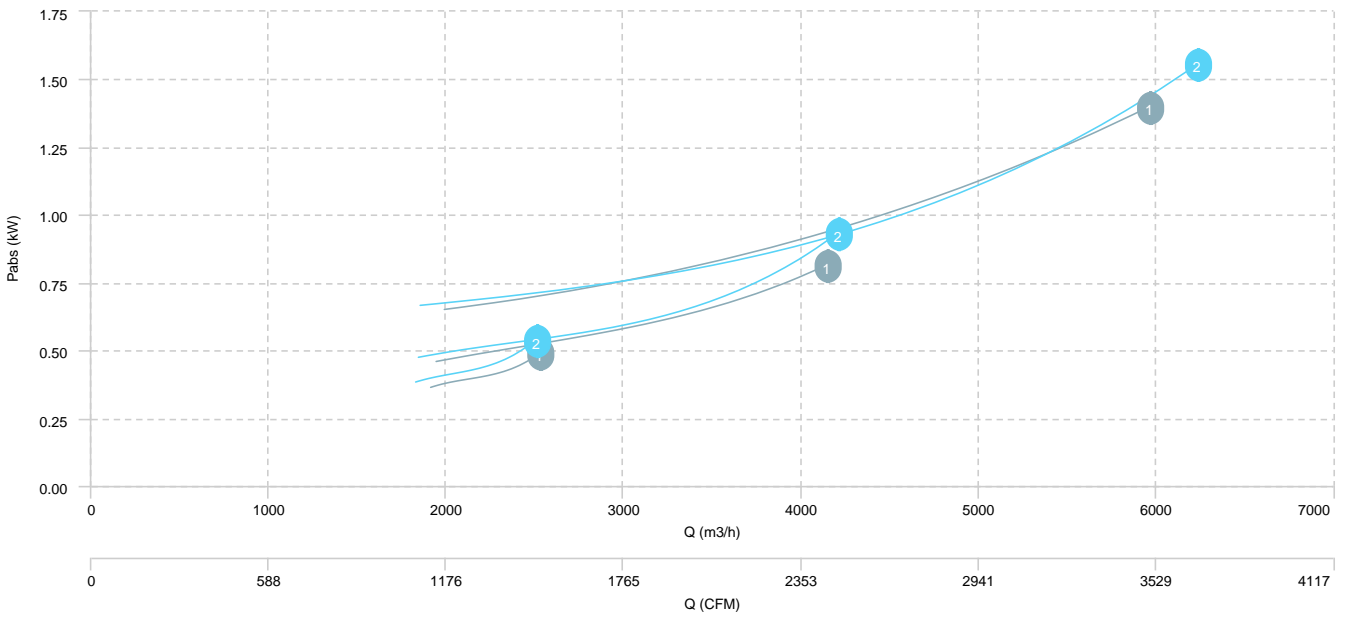

Sound data

Sound / 4 poles

Sound power Lw dB (A)										
Model		63 Hz	125 Hz	250 Hz	500 Hz	1000 Hz	2000 Hz	4000 Hz	8000 Hz	Total
BD 7/7 M4 0,12kW 3V* (1126 RPM)	Inlet	58	60	68	70	74	73	69	60	79
BD 9/7 M4 0,35kW 3V (1167 RPM)	Inlet	71	73	81	83	87	86	82	73	92
BD 9/9 M4 0,35kW 3V (1167 RPM)	Inlet	58	60	68	70	74	74	69	60	79
BD 10/8 M4 0,59kW 3V (1032 RPM)	Inlet	73	75	84	86	89	89	85	75	94
BD 10/10 M4 0,59kW 3V (1032 RPM)	Inlet	62	64	73	75	79	78	74	64	83

Sound / 6 poles

Sound power Lw dB (A)										
Model		63 Hz	125 Hz	250 Hz	500 Hz	1000 Hz	2000 Hz	4000 Hz	8000 Hz	Total
BD 12/9 M6 0,79kW 3V* (749 RPM)	Inlet	68	70	79	81	84	84	80	70	89
BD 12/12 M6 0,79kW 3V* (749 RPM)	Inlet	67	69	78	80	83	83	79	69	88

Notes:

* To calculate the sound power level at different rpm from those indicated above, use the following formula:

$$Lw \text{ dB(A)}_{rpmA} = Lw \text{ dB(A)}_{rpmB} + 52.5 \cdot \log_{10} \frac{rpmA}{rpmB}$$

erp data

ERP	
Fan type	Centrifugal fan radial or forward blades
Installation category	A
Efficiency category	Static
The fan has to be installed with FSC	No

ERP / 4 poles

Model	Motor power (kW)	Maximum efficiency point data						
		Max. efficiency (%)	Efficiency grade (N) (N)	Air Flow (m3/h)	Ps (Pa)	Pabs (kW)	speed (rpm)	Specific ratio
BD 9/7 M4 0,35kW 3V	0,35	40,95	51,75	769,10	362,72	0,20	1167	1,00
BD 9/7 M4 0,35kW 3V	0,35	46,10	55,74	1.212,49	379,91	0,30	1260	1,00
BD 9/7 M4 0,35kW 3V	0,35	36,79	45,55	1.542,66	356,34	0,41	1400	1,00
BD 9/9 M4 0,35kW 3V	0,35	33,55	43,99	828,98	324,76	0,22	1167	1,00
BD 9/9 M4 0,35kW 3V	0,35	40,12	49,56	1.324,08	336,96	0,32	1260	1,00
BD 9/9 M4 0,35kW 3V	0,35	35,46	44,10	1.692,34	320,17	0,43	1400	1,00
BD 10/8 M4 0,59kW 3V	0,59	32,25	41,87	836,54	417,56	0,30	1032	1,00
BD 10/8 M4 0,59kW 3V	0,59	40,64	49,51	1.204,78	465,73	0,40	1216	1,00
BD 10/8 M4 0,59kW 3V	0,59	38,70	45,97	2.241,52	458,38	0,71	1400	1,00
BD 10/10 M4 0,59kW 3V	0,59	28,42	37,81	832,91	385,51	0,33	1032	1,00
BD 10/10 M4 0,59kW 3V	0,59	38,54	47,35	1.224,28	450,84	0,41	1216	1,00
BD 10/10 M4 0,59kW 3V	0,59	41,73	49,02	2.472,05	436	0,71	1400	1,00