

## HCFX (F400+ATEX)



SHORT CASE AXIAL ATEX FAN 400°C/2H

MANUFACTURING FEATURES:

- Axial fan short casing with circular reinforced frame.
- Modular motor-impeller assembly. Cast aluminium impeller with variable pitch angle. Polyester powder finishing coat.
- Standard asynchronous squirrel-cage motor with IP-55 protection and Class H insulation certified 400°C/2h and ATEX (II3G). Manufactured with standard voltages: 230/400V 50Hz in three phase motors up to 3kW and 400V 50Hz for higher powers and 2 speed motors. IE3 efficiency motor from 0,75kW up to 45kW in single speed
- Protection ring made of aluminium.

APPLICATIONS:

Designed for inline installation, they are suitable for:

- Smoke emergency exhaust with motor inside the hazardous area.
- Maximum working temperature: 60°C.

UNDER REQUEST:

- Supply impeller (air direction from impeller to motor).
- 100% reversible impeller.

Official homologation by the European laboratory APPLUS according to EN 12101-3:2015

Certification Nr: 0370-CPR-0912

## Accessories



AC



AVS



BA-400



BAD



INT



INT 400



INT ATEX



JE 45



KIT TM



PO



RP



RP1



SFC



SIL-C /  
SIL-CN

## Technical data

### Three-phase motor / 4 poles

Code	Model	Angle	Min. Rated power kW	Max. Rated power kW	Max. Airflow m <sup>3</sup> /h	Sound db (A)**	Weight kg	Connect. diagram
	HCFX 45 T4 (A5:6) F400	20° - 42,5°	0,75	0,75	6.170	51	14	1
	HCFX 50 T4 (A5:6) F400	25° - 45°	0,75	0,75	9.180	55	20	1
	HCFX 56 T4 (A5:6) F400	20° - 45°	0,75	1,50	14.480	70	22	1
	HCFX 63 T4 (A5:6) F400	20° - 45°	0,75	2,20	20.110	74	25	1
	HCFX 71 T4 (A5:6) F400	20° - 45°	0,75	3,00	27.220	79	32	1
	HCFX 80 T4 (A5:6) F400	20° - 45°	2,20	4,00	37.370	76	39	1
	HCFX 90 T4 (A3:4) F400	20° - 42°	3,00	15,00	48.110	67	86	1
	HCFX 90 T4 (A3:8) F400	20° - 42°	3,00	15,00	54.810	72	91	1
	HCFX 100 T4 (A3:4) F400	20° - 42°	5,50	22,00	67.210	72	106	1
	HCFX 100 T4 (A3:8) F400	20° - 42°	5,50	22,00	77.810	81	111	1
	HCFX 112 T4 (A3:4) F400	20° - 42°	7,50	37,00	92.110	76	131	1
	HCFX 112 T4 (A3:8) F400	20° - 42°	7,50	37,00	104.010	83	137	1
	HCFX 125 T4 (A3:4) F400	20° - 42°	11,00	45,00	124.010	83	144	1
	HCFX 125 T4 (A3:8) F400	20° - 42°	11,00	45,00	141.010	89	151	1

### Three-phase motor / 6 poles

Code	Model	Angle	Min. Rated power kW	Max. Rated power kW	Max. Airflow m <sup>3</sup> /h	Sound db (A)**	Weight kg	Connect. diagram
	HCFX 45 T6 (A5:6) F400	25° - 45°	0,75	0,75	4.060	42	14	1
	HCFX 50 T6 (A5:6) F400	25° - 45°	0,75	0,75	5.950	46	20	1
	HCFX 56 T6 (A5:6) F400	20° - 45°	0,75	0,75	9.660	67	22	1
	HCFX 63 T6 (A5:6) F400	20° - 45°	0,75	0,75	13.410	71	25	1
	HCFX 71 T6 (A5:6) F400	20° - 45°	0,75	0,75	18.150	76	32	1
	HCFX 80 T6 (A5:6) F400	20° - 45°	0,75	2,20	24.910	72	39	1
	HCFX 90 T6 (A3:4) F400	20° - 42°	1,50	5,50	31.210	57	86	1
	HCFX 90 T6 (A3:8) F400	20° - 42°	1,50	5,50	35.510	62	91	1
	HCFX 100 T6 (A3:4) F400	20° - 42°	3,00	7,50	43.610	63	106	1
	HCFX 100 T6 (A3:8) F400	20° - 42°	3,00	7,50	50.410	71	111	1
	HCFX 112 T6 (A3:4) F400	20° - 42°	3,00	11,00	59.710	66	131	1
	HCFX 112 T6 (A3:8) F400	20° - 42°	3,00	11,00	67.610	73	137	1
	HCFX 125 T6 (A3:4) F400	20° - 42°	3,00	15,00	80.610	73	144	1
	HCFX 125 T6 (A3:8) F400	20° - 42°	3,00	15,00	91.410	80	151	1

## 2 speed motor / 4/8 poles

Code	Model	Angle	Min. Rated power kW	Max. Rated power kW	Max. Airflow m <sup>3</sup> /h	Sound db (A)**	Weight kg	Connect. diagram
	HCFX 45 T4/T8 (A5:6) F400	20° - 42,5°	0,60	1,60	6.170	51	14	1
	HCFX 50 T4/T8 (A5:6) F400	25° - 45°	0,60	1,60	9.180	55	20	1
	HCFX 56 T4/T8 (A5:6) F400	20° - 45°	0,60	2,80	14.480	70	22	2
	HCFX 63 T4/T8 (A5:6) F400	20° - 45°	0,60	2,80	20.110	74	25	2
	HCFX 71 T4/T8 (A5:6) F400	20° - 45°	0,60	4,00	27.220	79	32	2
	HCFX 80 T4/T8 (A5:6) F400	20° - 45°	1,20	7,50	37.370	76	39	2
	HCFX 90 T4/T8 (A3:4) F400	20° - 42°	2,80	17,00	48.110	67	86	2
	HCFX 90 T4/T8 (A3:8) F400	20° - 42°	5,50	17,00	54.810	72	91	2
	HCFX 100 T4/T8 (A3:4) F400	20° - 42°	5,50	20,00	67.210	72	106	2
	HCFX 100 T4/T8 (A3:8) F400	20° - 42°	5,50	20,00	77.810	81	111	2
	HCFX 112 T4/T8 (A3:4) F400	20° - 42°	5,50	37,00	92.110	76	131	2
	HCFX 112 T4/T8 (A3:8) F400	20° - 42°	5,50	37,00	104.010	83	137	2
	HCFX 125 T4/T8 (A3:4) F400	20° - 42°	7,50	44,00	124.010	83	144	2
	HCFX 125 T4/T8 (A3:8) F400	20° - 42°	7,50	44,00	141.010	89	151	2

**Notes:**

\* The motor is not included in fan weight

\*\* Total sound pressure level at the point of maximum flow measured in dB(A) in the suction measured in free field at a distance of 6m from the source

## Dimensions

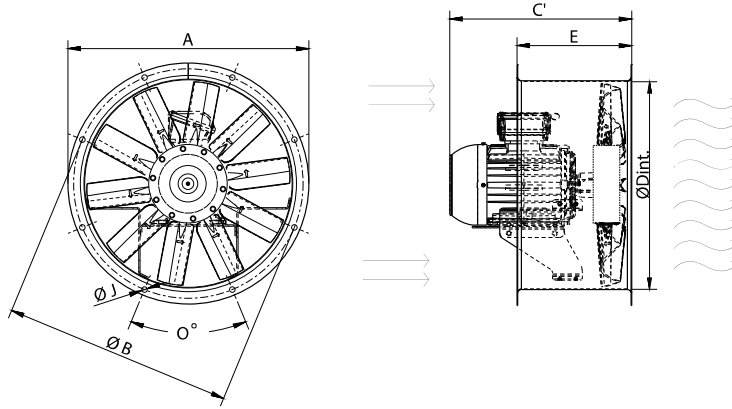

Model	C' (Mot. T.63)	C' (Mot. T.71)	C' (Mot. T.80)	C' (Mot. T.90L)	C' (Mot. T.90S)	C' (Mot. T.100L)	C' (Mot. T.112)	C' (Mot. T.112M)	C' (Mot. T.132)
HCFX 45 T4 (A5:6) F400	338	348	357	397	372	428	-	-	-
HCFX 45 T6 (A5:6) F400	338	348	357	397	372	428	-	-	-
HCFX 45 T4/T8 (A5:6) F400	338	348	357	397	372	428	-	-	-
HCFX 50 T4 (A5:6) F400	-	348	360	397	372	428	-	-	-
HCFX 50 T6 (A5:6) F400	-	348	360	397	372	428	-	-	-
HCFX 50 T4/T8 (A5:6) F400	-	348	360	397	372	428	-	-	-
HCFX 56 T4 (A5:6) F400	-	348	362	397	372	433	-	-	-
HCFX 56 T6 (A5:6) F400	-	348	362	397	372	433	-	-	-
HCFX 56 T4/T8 (A5:6) F400	-	348	362	397	372	433	-	-	-
HCFX 63 T4 (A5:6) F400	-	-	359	398	393	450	-	471	-
HCFX 63 T6 (A5:6) F400	-	-	359	398	393	450	-	471	-
HCFX 63 T4/T8 (A5:6) F400	-	-	359	398	393	450	-	471	-
HCFX 71 T4 (A5:6) F400	-	-	362	421	396	452	-	473	-
HCFX 71 T6 (A5:6) F400	-	-	362	421	396	452	-	473	-
HCFX 71 T4/T8 (A5:6) F400	-	-	362	421	396	452	-	473	-
HCFX 80 T4 (A5:6) F400	-	-	-	445	445	476	-	477	-
HCFX 80 T6 (A5:6) F400	-	-	-	445	445	476	-	477	-
HCFX 80 T4/T8 (A5:6) F400	-	-	-	445	445	476	-	477	-
HCFX 90 T4 (A3:4) F400	-	-	-	-	-	655	655	-	655
HCFX 90 T4 (A3:8) F400	-	-	-	-	-	655	655	-	655
HCFX 90 T6 (A3:4) F400	-	-	-	-	-	655	655	-	655
HCFX 90 T6 (A3:8) F400	-	-	-	-	-	655	655	-	655
HCFX 90 T4/T8 (A3:4) F400	-	-	-	-	-	655	655	-	655
HCFX 90 T4/T8 (A3:8) F400	-	-	-	-	-	655	655	-	655

Model	C' (Mot. T.63)	C' (Mot. T.71)	C' (Mot. T.80)	C' (Mot. T.90L)	C' (Mot. T.90S)	C' (Mot. T.100L)	C' (Mot. T.112)	C' (Mot. T.112M)	C' (Mot. T.132)
HCFX 100 T4 (A3:4) F400	-	-	-	-	-	-	-	-	655
HCFX 100 T4 (A3:8) F400	-	-	-	-	-	-	-	-	655
HCFX 100 T6 (A3:4) F400	-	-	-	-	-	-	-	-	655
HCFX 100 T6 (A3:8) F400	-	-	-	-	-	-	-	-	655
HCFX 100 T4/T8 (A3:4) F400	-	-	-	-	-	-	-	-	655
HCFX 100 T4/T8 (A3:8) F400	-	-	-	-	-	-	-	-	655
HCFX 112 T4 (A3:4) F400	-	-	-	-	-	-	-	-	765
HCFX 112 T4 (A3:8) F400	-	-	-	-	-	-	-	-	765
HCFX 112 T6 (A3:4) F400	-	-	-	-	-	-	-	-	765
HCFX 112 T6 (A3:8) F400	-	-	-	-	-	-	-	-	765
HCFX 112 T4/T8 (A3:4) F400	-	-	-	-	-	-	-	-	765
HCFX 112 T4/T8 (A3:8) F400	-	-	-	-	-	-	-	-	765
HCFX 125 T4 (A3:4) F400	-	-	-	-	-	-	-	-	765
HCFX 125 T4 (A3:8) F400	-	-	-	-	-	-	-	-	765
HCFX 125 T6 (A3:4) F400	-	-	-	-	-	-	-	-	765
HCFX 125 T6 (A3:8) F400	-	-	-	-	-	-	-	-	765
HCFX 125 T4/T8 (A3:4) F400	-	-	-	-	-	-	-	-	765
HCFX 125 T4/T8 (A3:8) F400	-	-	-	-	-	-	-	-	765

Model	C' (Mot. T.132M)	C' (Mot. T.132S)	C' (Mot. T.160L)	C' (Mot. T.160M)	C' (Mot. T.180L)	C' (Mot. T.180M)	C' (Mot. T.200)	C' (Mot. T.225)	E
HCFX 45 T4 (A5:6) F400	-	-	-	-	-	-	-	-	250
HCFX 45 T6 (A5:6) F400	-	-	-	-	-	-	-	-	250
HCFX 45 T4/T8 (A5:6) F400	-	-	-	-	-	-	-	-	250
HCFX 50 T4 (A5:6) F400	-	-	-	-	-	-	-	-	250
HCFX 50 T6 (A5:6) F400	-	-	-	-	-	-	-	-	250
HCFX 50 T4/T8 (A5:6) F400	-	-	-	-	-	-	-	-	250
HCFX 56 T4 (A5:6) F400	-	-	-	-	-	-	-	-	250
HCFX 56 T6 (A5:6) F400	-	-	-	-	-	-	-	-	250
HCFX 56 T4/T8 (A5:6) F400	-	-	-	-	-	-	-	-	250
HCFX 63 T4 (A5:6) F400	-	-	-	-	-	-	-	-	250
HCFX 63 T6 (A5:6) F400	-	-	-	-	-	-	-	-	250
HCFX 63 T4/T8 (A5:6) F400	-	-	-	-	-	-	-	-	250
HCFX 71 T4 (A5:6) F400	-	-	-	-	-	-	-	-	350
HCFX 71 T6 (A5:6) F400	-	-	-	-	-	-	-	-	350
HCFX 71 T4/T8 (A5:6) F400	-	-	-	-	-	-	-	-	350
HCFX 80 T4 (A5:6) F400	571	533	-	-	-	-	-	-	350
HCFX 80 T6 (A5:6) F400	571	533	-	-	-	-	-	-	350
HCFX 80 T4/T8 (A5:6) F400	571	533	-	-	-	-	-	-	350
HCFX 90 T4 (A3:4) F400	-	-	762	718	794	756	-	-	425

Model	C' (Mot. T.132M)	C' (Mot. T.132S)	C' (Mot. T.160L)	C' (Mot. T.160M)	C' (Mot. T.180L)	C' (Mot. T.180M)	C' (Mot. T.200)	C' (Mot. T.225)	E
HCFX 90 T4 (A3:8) F400	-	-	762	718	794	756	-	-	425
HCFX 90 T6 (A3:4) F400	-	-	762	718	794	756	-	-	425
HCFX 90 T6 (A3:8) F400	-	-	762	718	794	756	-	-	425
HCFX 90 T4/T8 (A3:4) F400	-	-	762	718	794	756	-	-	425
HCFX 90 T4/T8 (A3:8) F400	-	-	762	718	794	756	-	-	425
HCFX 100 T4 (A3:4) F400	-	-	762	718	794	756	-	-	425
HCFX 100 T4 (A3:8) F400	-	-	762	718	794	756	-	-	425
HCFX 100 T6 (A3:4) F400	-	-	762	718	794	756	-	-	425
HCFX 100 T6 (A3:8) F400	-	-	762	718	794	756	-	-	425
HCFX 100 T4/T8 (A3:4) F400	-	-	762	718	794	756	-	-	425
HCFX 100 T4/T8 (A3:8) F400	-	-	762	718	794	756	-	-	425
HCFX 112 T4 (A3:4) F400	-	-	772	765	804	766	869	954	500
HCFX 112 T4 (A3:8) F400	-	-	772	765	804	766	869	954	500
HCFX 112 T6 (A3:4) F400	-	-	772	765	804	766	869	954	500
HCFX 112 T6 (A3:8) F400	-	-	772	765	804	766	869	954	500
HCFX 112 T4/T8 (A3:4) F400	-	-	772	765	804	766	869	954	500
HCFX 112 T4/T8 (A3:8) F400	-	-	772	765	804	766	869	954	500
HCFX 125 T4 (A3:4) F400	-	-	772	765	804	766	869	954	500
HCFX 125 T4 (A3:8) F400	-	-	772	765	804	766	869	954	500
HCFX 125 T6 (A3:4) F400	-	-	772	765	804	766	869	954	500
HCFX 125 T6 (A3:8) F400	-	-	772	765	804	766	869	954	500
HCFX 125 T4/T8 (A3:4) F400	-	-	772	765	804	766	869	954	500
HCFX 125 T4/T8 (A3:8) F400	-	-	772	765	804	766	869	954	500

Model	O	ØA	ØB	ØD	ØJ
HCFX 45 T4 (A5:6) F400	8X45 <sup>º</sup>	525	500	452	12
HCFX 45 T6 (A5:6) F400	8X45 <sup>º</sup>	525	500	452	12
HCFX 45 T4/T8 (A5:6) F400	8X45 <sup>º</sup>	525	500	452	12
HCFX 50 T4 (A5:6) F400	12x30 <sup>º</sup>	600	560	504	12
HCFX 50 T6 (A5:6) F400	12x30 <sup>º</sup>	600	560	504	12
HCFX 50 T4/T8 (A5:6) F400	12x30 <sup>º</sup>	600	560	504	12
HCFX 56 T4 (A5:6) F400	12X30 <sup>º</sup>	646	620	559	12
HCFX 56 T6 (A5:6) F400	12X30 <sup>º</sup>	646	620	559	12
HCFX 56 T4/T8 (A5:6) F400	12X30 <sup>º</sup>	646	620	559	12
HCFX 63 T4 (A5:6) F400	12X30 <sup>º</sup>	725	690	633	12
HCFX 63 T6 (A5:6) F400	12X30 <sup>º</sup>	725	690	633	12
HCFX 63 T4/T8 (A5:6) F400	12X30 <sup>º</sup>	725	690	633	12
HCFX 71 T4 (A5:6) F400	16x22,5 <sup>º</sup>	802	770	715	12
HCFX 71 T6 (A5:6) F400	16x22,5 <sup>º</sup>	802	770	715	12
HCFX 71 T4/T8 (A5:6) F400	16x22,5 <sup>º</sup>	802	770	715	12

Model	O	ØA	ØB	ØD	ØJ
HCFX 80 T4 (A5:6) F400	16x22,5º	892	860	801	12
HCFX 80 T6 (A5:6) F400	16x22,5º	892	860	801	12
HCFX 80 T4/T8 (A5:6) F400	16x22,5º	892	860	801	12
HCFX 90 T4 (A3:4) F400	16x22,5º	1000	970	903.5	12
HCFX 90 T4 (A3:8) F400	16x22,5º	1000	970	903.5	12
HCFX 90 T6 (A3:4) F400	16x22,5º	1000	970	903.5	12
HCFX 90 T6 (A3:8) F400	16x22,5º	1000	970	903.5	12
HCFX 90 T4/T8 (A3:4) F400	16x22,5º	1000	970	903.5	12
HCFX 90 T4/T8 (A3:8) F400	16x22,5º	1000	970	903.5	12
HCFX 100 T4 (A3:4) F400	16x22,5º	1115	1070	1013	12
HCFX 100 T4 (A3:8) F400	16x22,5º	1115	1070	1013	12
HCFX 100 T6 (A3:4) F400	16x22,5º	1115	1070	1013	12
HCFX 100 T6 (A3:8) F400	16x22,5º	1115	1070	1013	12
HCFX 100 T4/T8 (A3:4) F400	16x22,5º	1115	1070	1013	12
HCFX 100 T4/T8 (A3:8) F400	16x22,5º	1115	1070	1013	12
HCFX 112 T4 (A3:4) F400	16x22,5º	1234	1190	1132	12
HCFX 112 T4 (A3:8) F400	16x22,5º	1234	1190	1132	12
HCFX 112 T6 (A3:4) F400	16x22,5º	1234	1190	1132	12
HCFX 112 T6 (A3:8) F400	16x22,5º	1234	1190	1132	12
HCFX 112 T4/T8 (A3:4) F400	16x22,5º	1234	1190	1132	12
HCFX 112 T4/T8 (A3:8) F400	16x22,5º	1234	1190	1132	12
HCFX 125 T4 (A3:4) F400	20x18º	1365	1320	1263	15
HCFX 125 T4 (A3:8) F400	20x18º	1365	1320	1263	15
HCFX 125 T6 (A3:4) F400	20x18º	1365	1320	1263	15
HCFX 125 T6 (A3:8) F400	20x18º	1365	1320	1263	15
HCFX 125 T4/T8 (A3:4) F400	20x18º	1365	1320	1263	15
HCFX 125 T4/T8 (A3:8) F400	20x18º	1365	1320	1263	15

# Wiring diagram

## Wiring diagram N° 1

230/400V

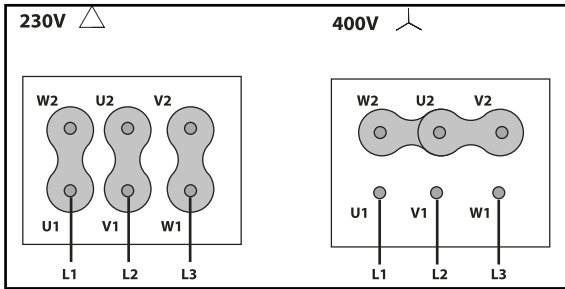

400/690V

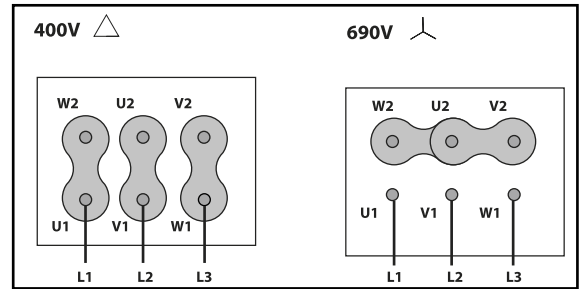

## Wiring diagram N° 2

400V DAHLANDER (Y,YY)

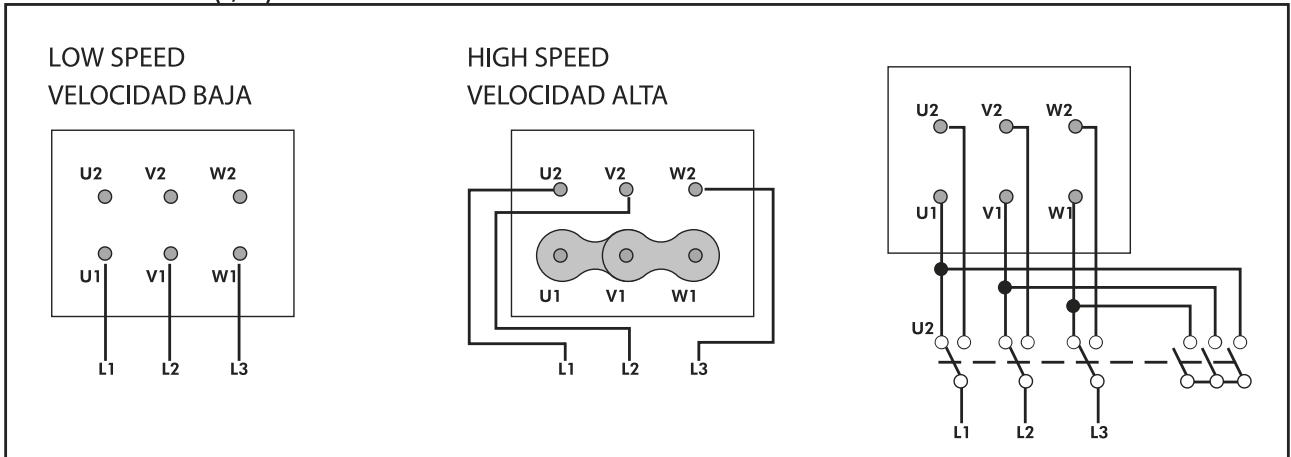



# CHARACTERISTIC CURVE

HCFX 45 T4 (A5:6) F400

## AIR FLOW - PRESSURE

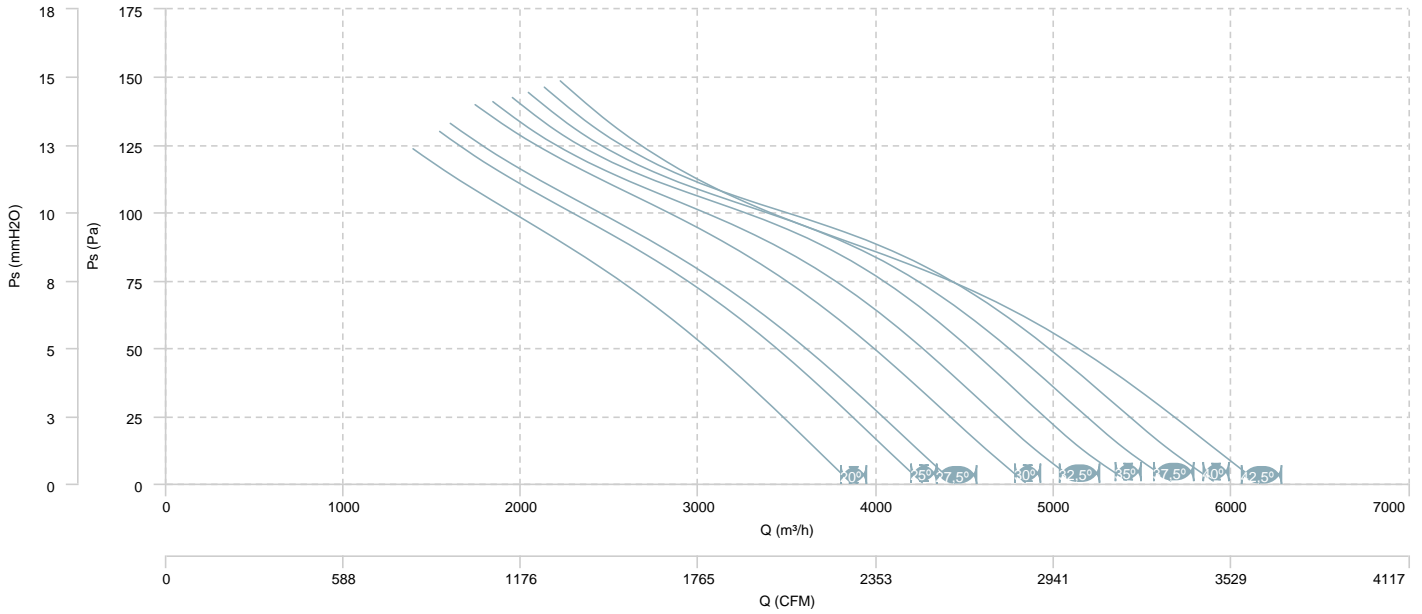

## AIR FLOW - MECHANICAL POWER

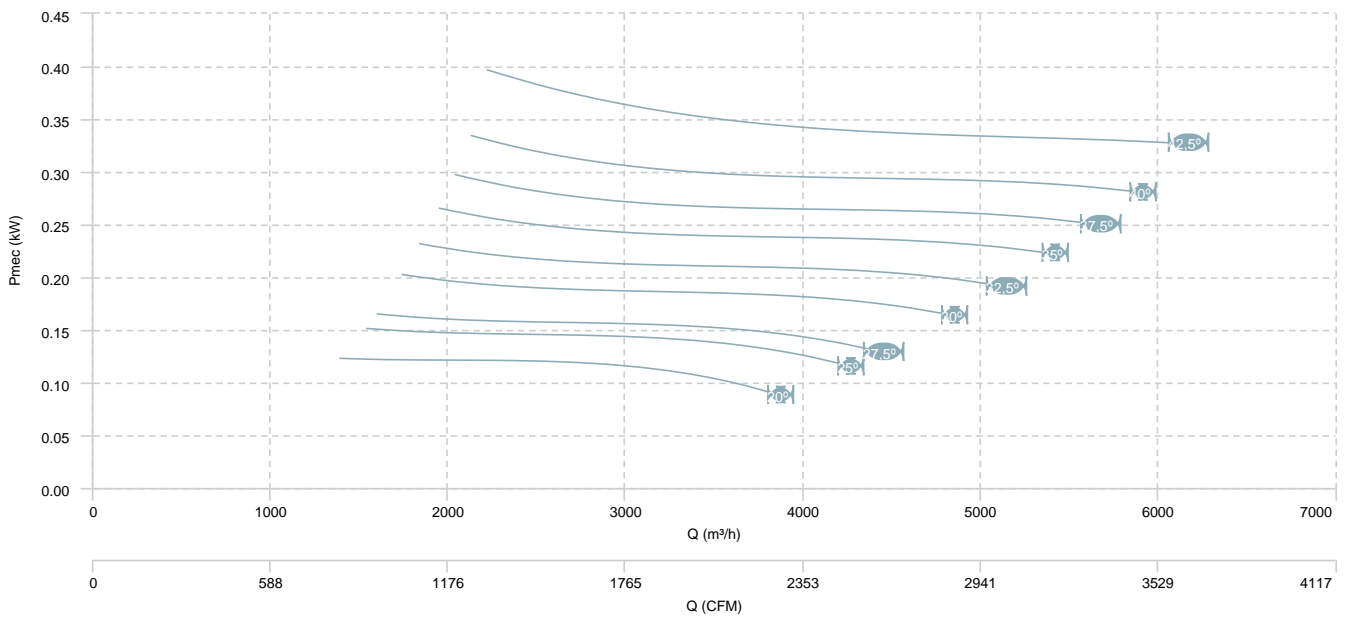

HCFX 45 T6 (A5:6) F400

**AIR FLOW - PRESSURE**

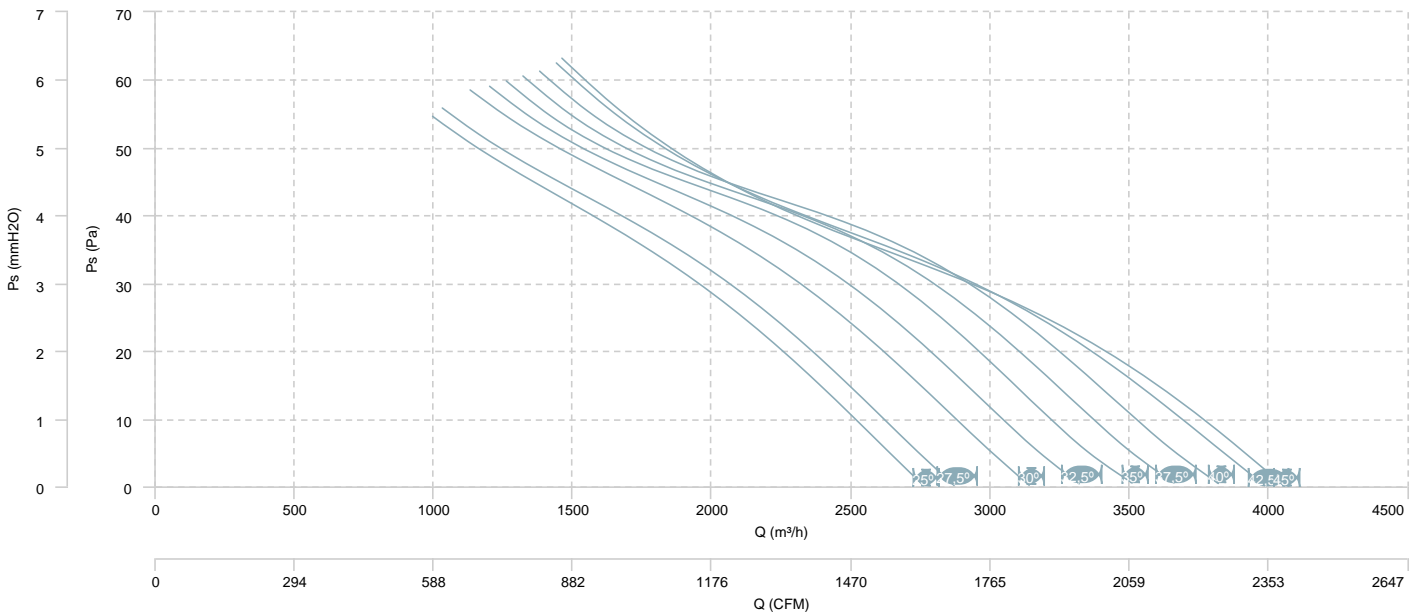

**AIR FLOW - MECHANICAL POWER**

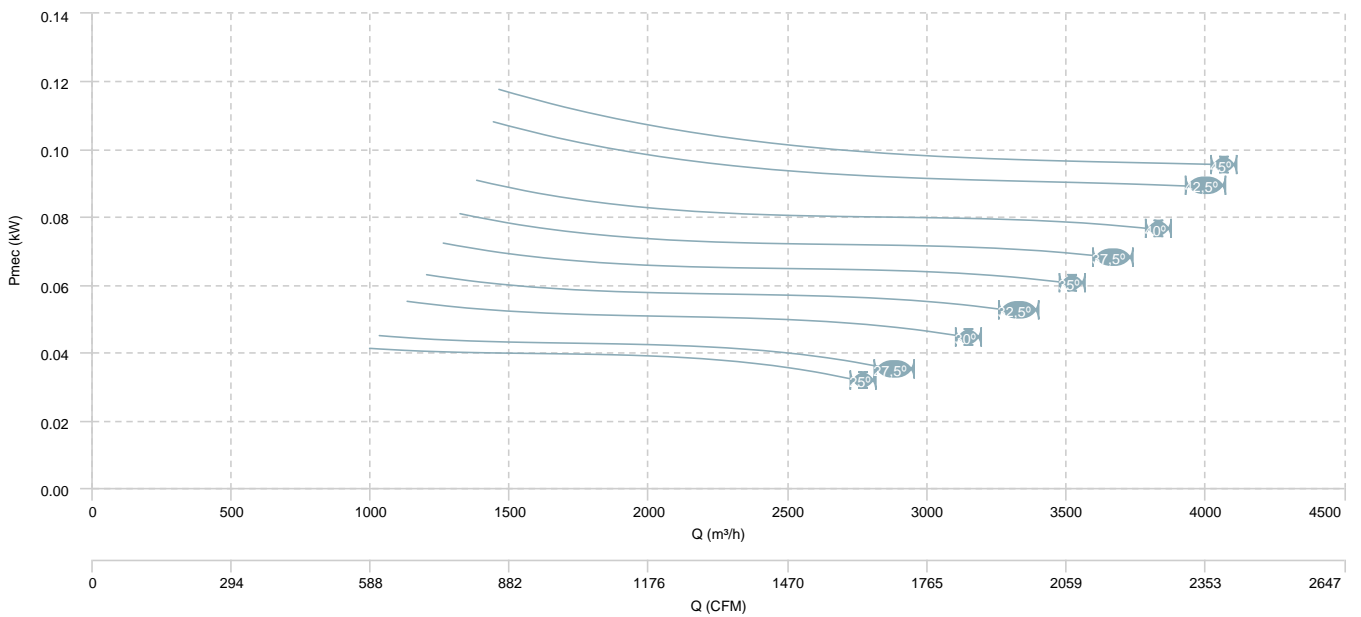

HCFX 45 T4/T8 (A5:6) F400

**AIR FLOW - PRESSURE (4 poles)**

HCFX 45 T4/T8 (A5:6) F400

**AIR FLOW - PRESSURE (8 poles)**

HCFX 50 T4 (A5:6) F400

**AIR FLOW - PRESSURE**

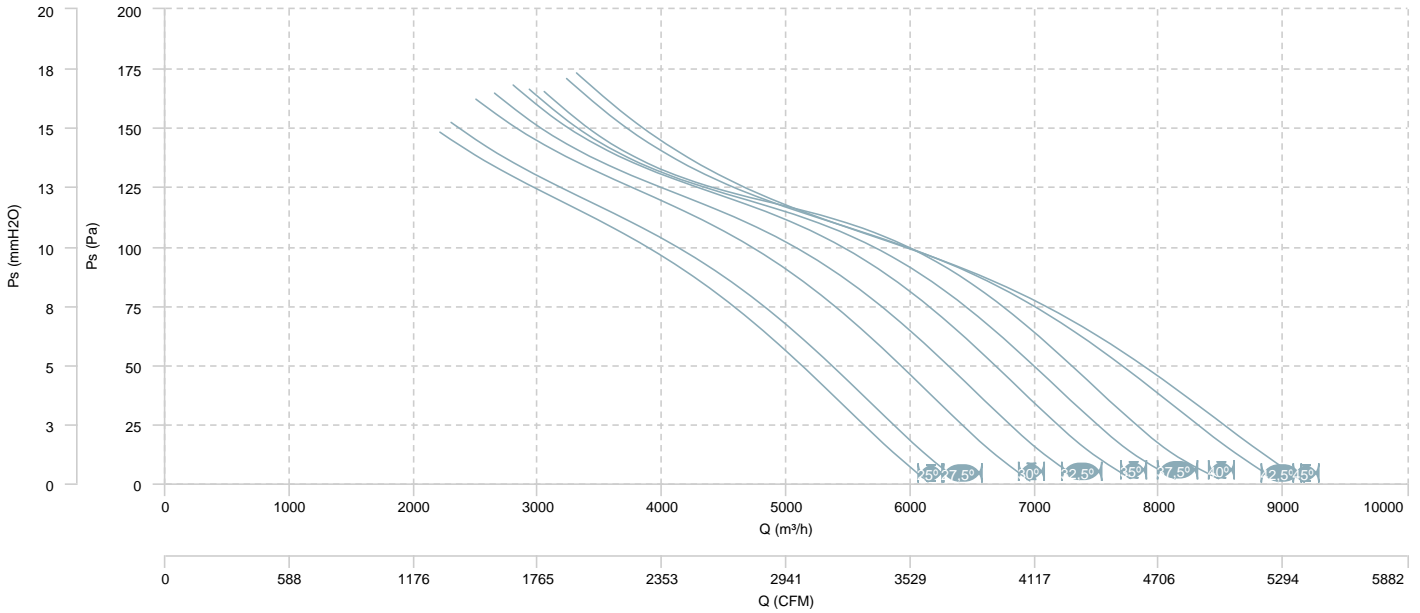

**AIR FLOW - MECHANICAL POWER**

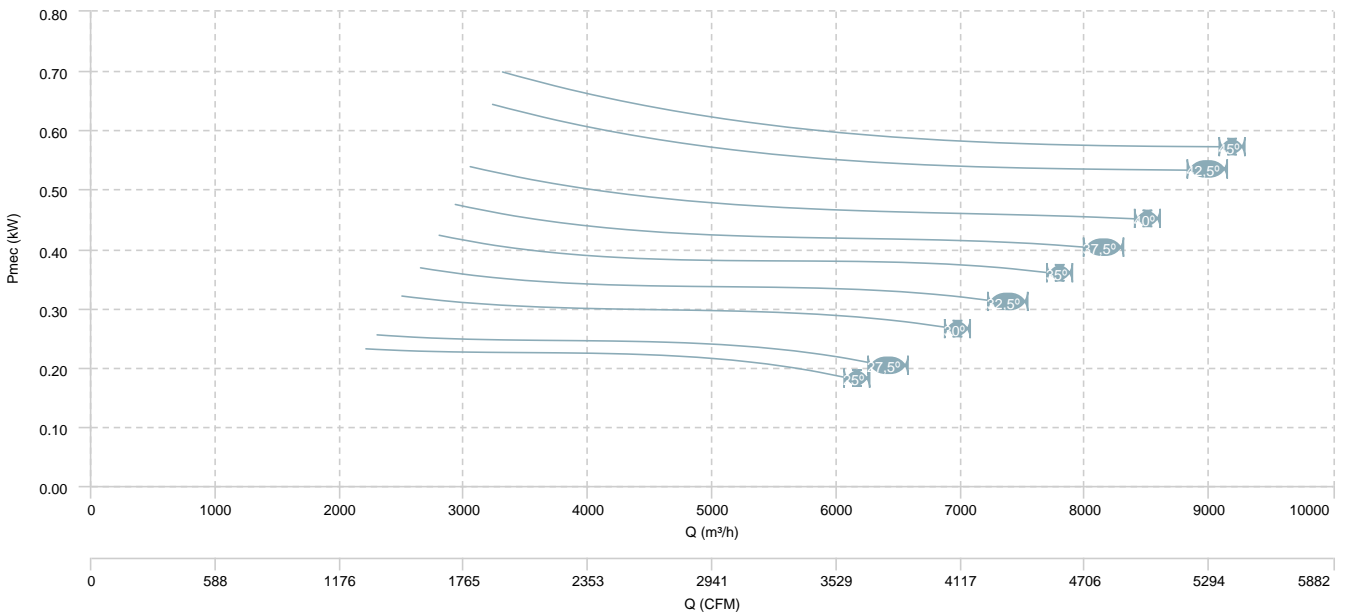

HCFX 50 T6 (A5:6) F400

**AIR FLOW - PRESSURE**

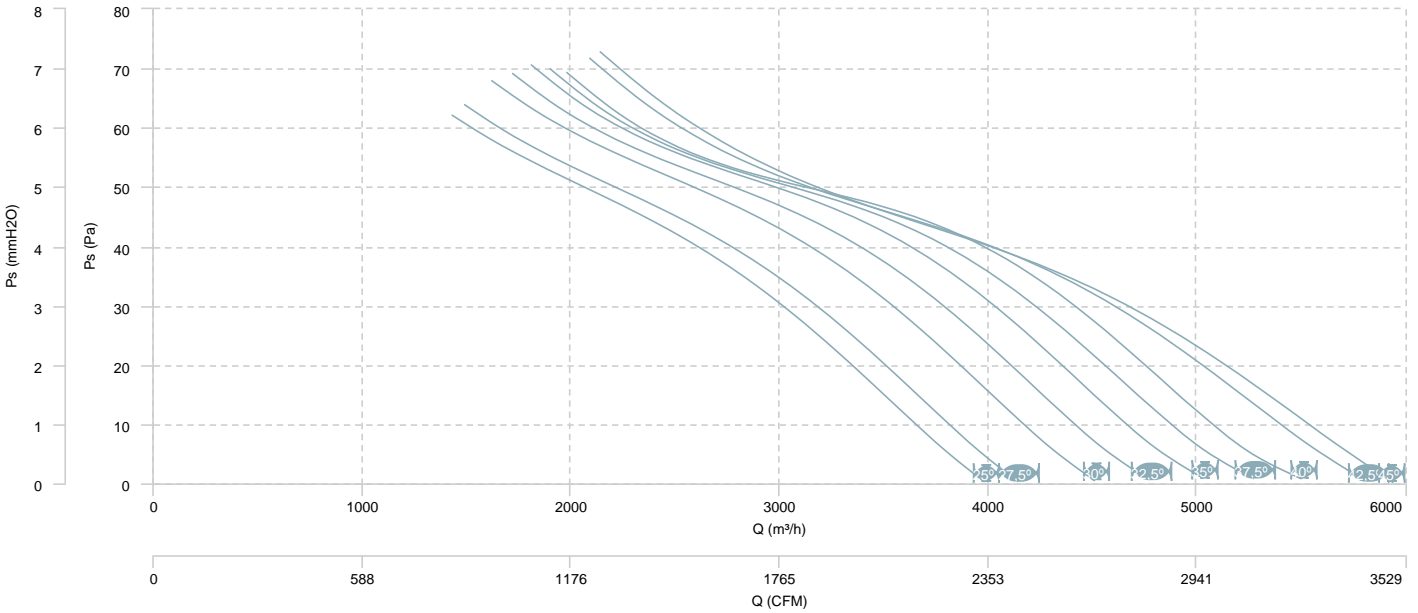

**AIR FLOW - MECHANICAL POWER**

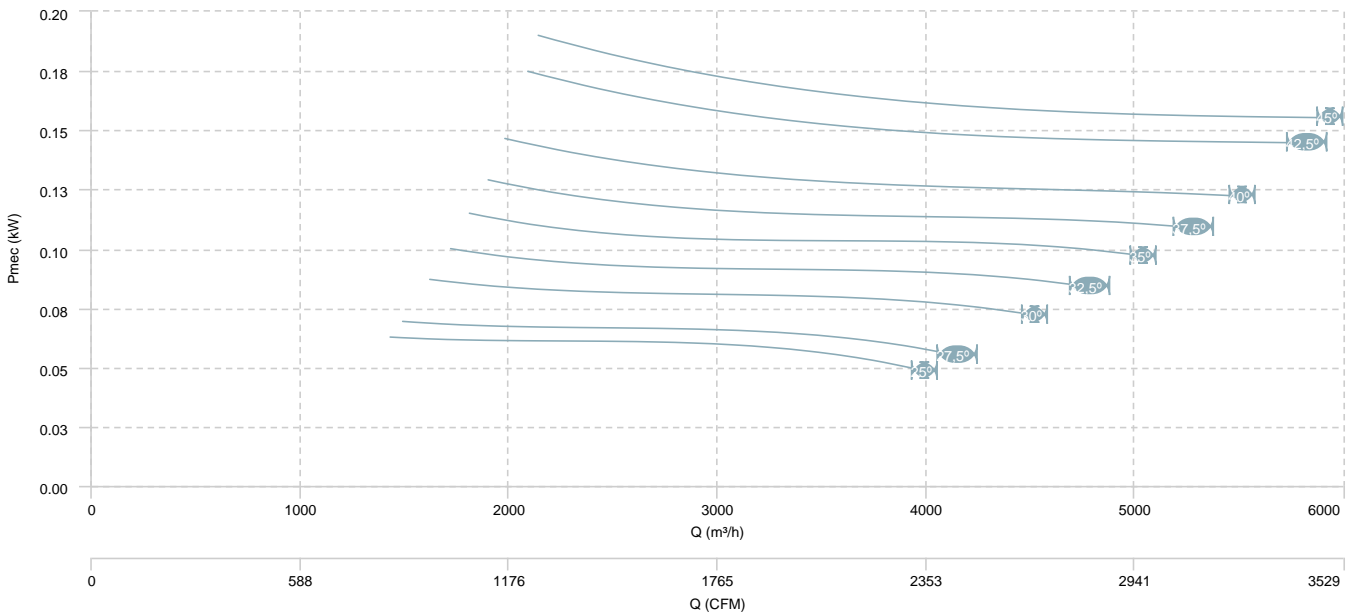

HCFX 50 T4/T8 (A5:6) F400

**AIR FLOW - PRESSURE (4 poles)**

HCFX 50 T4/T8 (A5:6) F400

**AIR FLOW - PRESSURE (8 poles)**



HCFX 56 T4 (A5:6) F400

**AIR FLOW - PRESSURE**

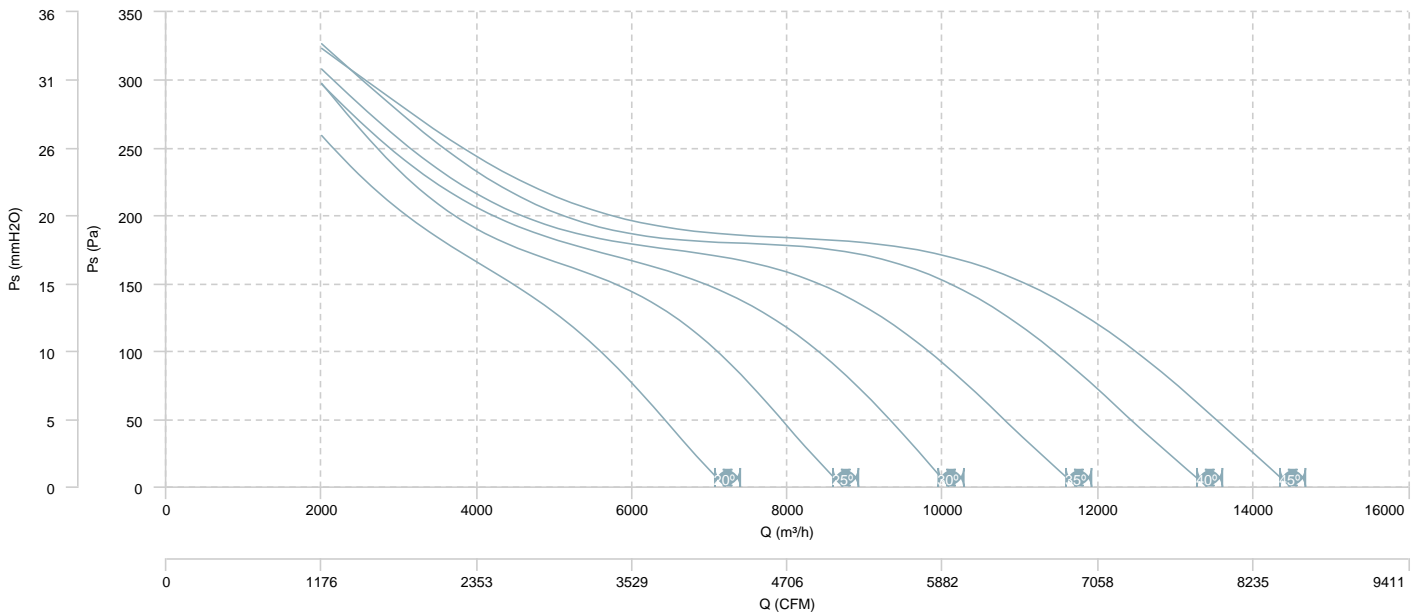

**AIR FLOW - MECHANICAL POWER**

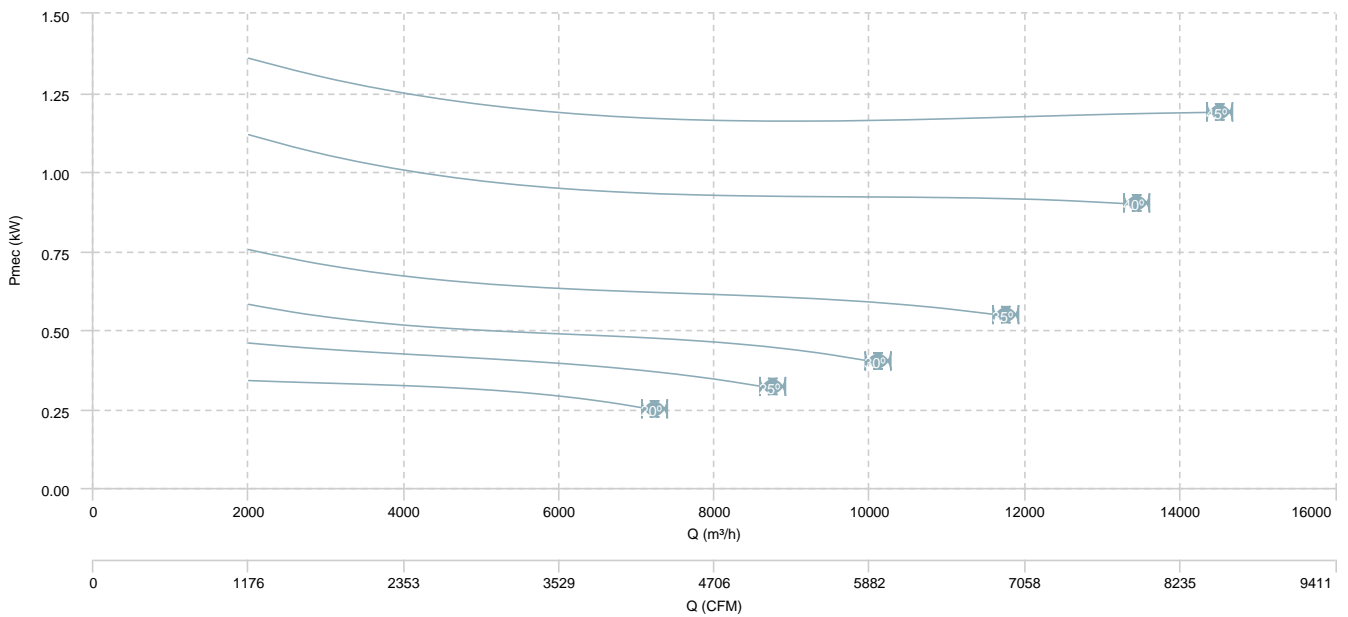

HCFX 56 T6 (A5:6) F400

**AIR FLOW - PRESSURE**

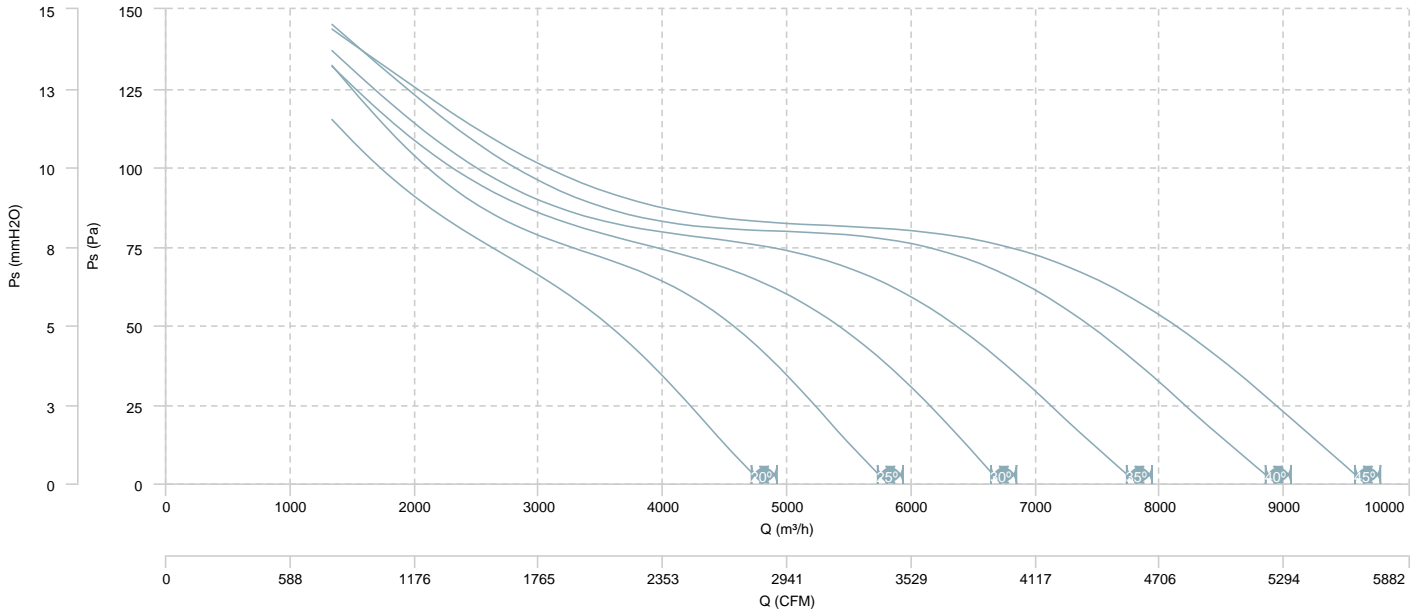

**AIR FLOW - MECHANICAL POWER**

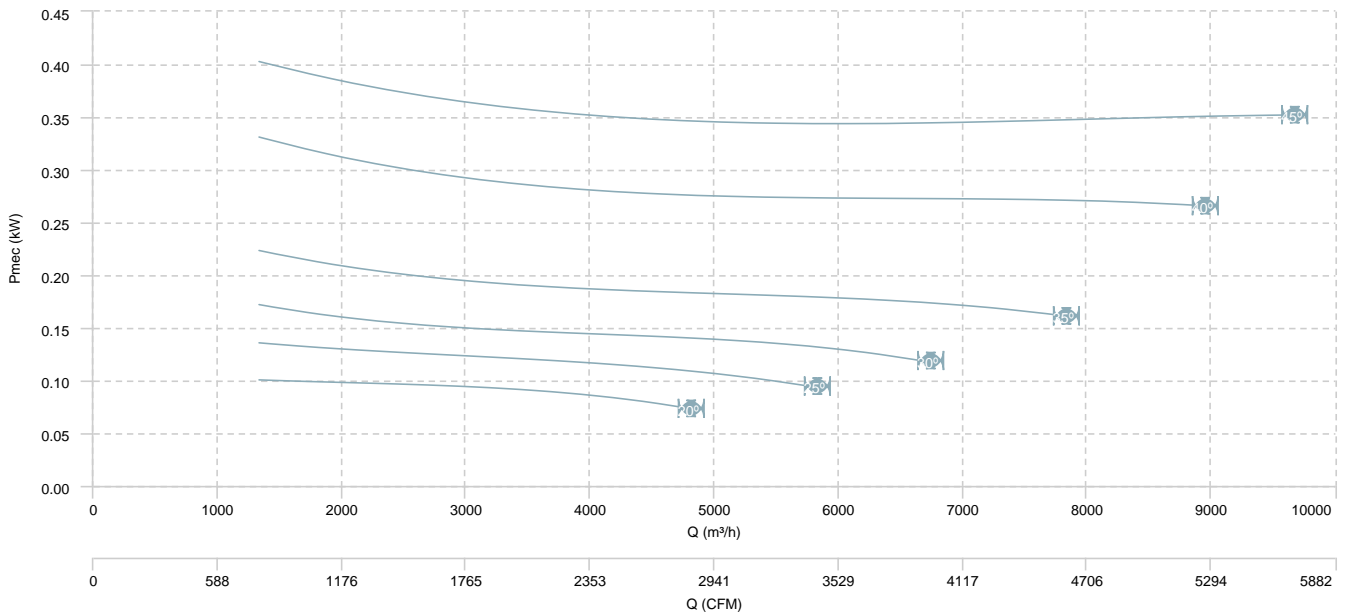

HCFX 56 T4/T8 (A5:6) F400

**AIR FLOW - PRESSURE (4 poles)**

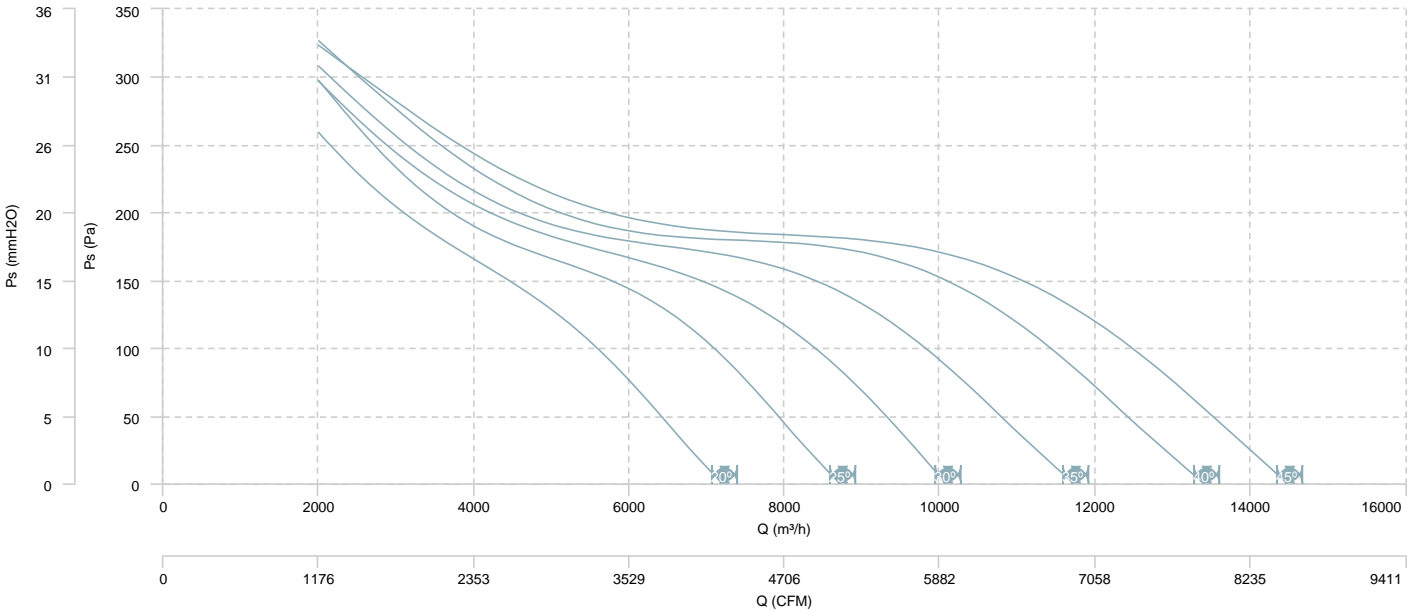

**AIR FLOW - MECHANICAL POWER (4 poles)**

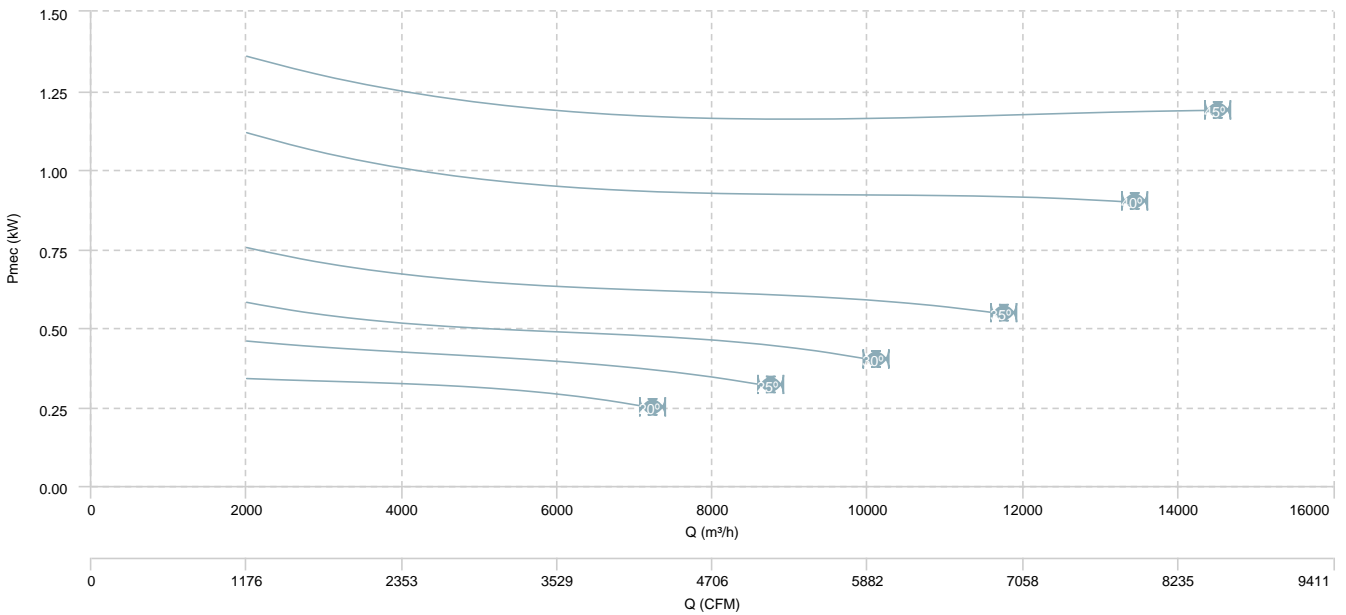

HCFX 56 T4/T8 (A5:6) F400

**AIR FLOW - PRESSURE (8 poles)**

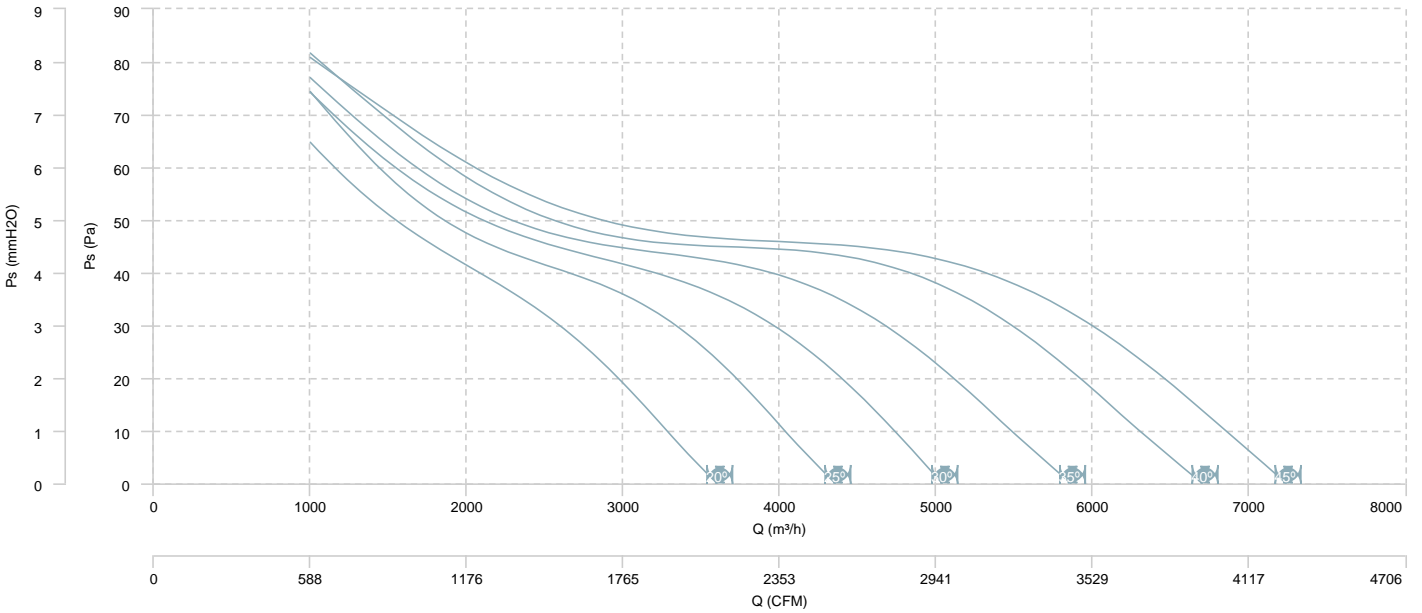

**AIR FLOW - MECHANICAL POWER (8 poles)**

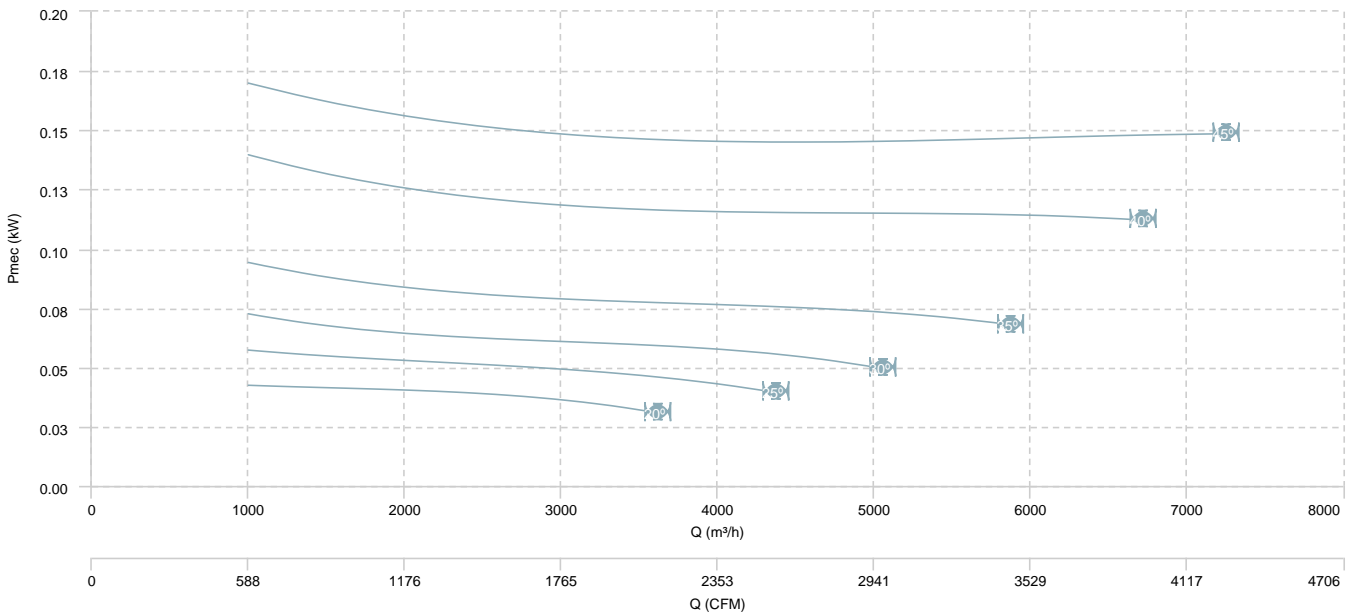

HCFX 63 T4 (A5:6) F400

**AIR FLOW - PRESSURE**

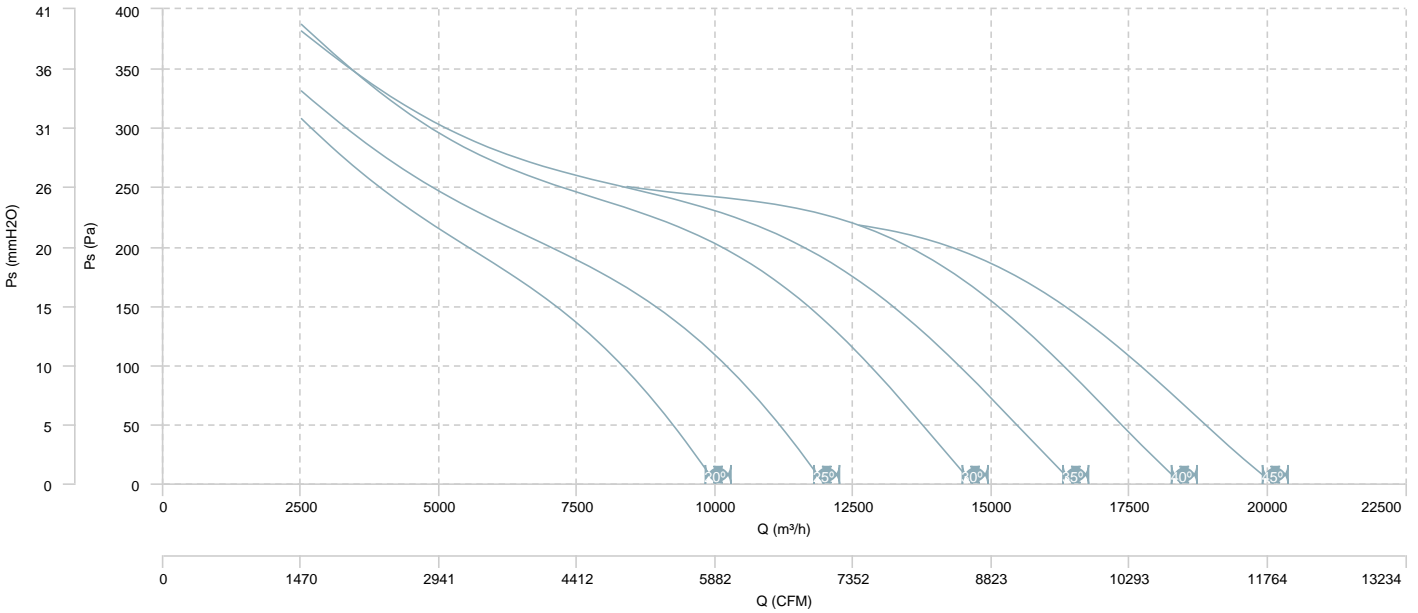

**AIR FLOW - MECHANICAL POWER**

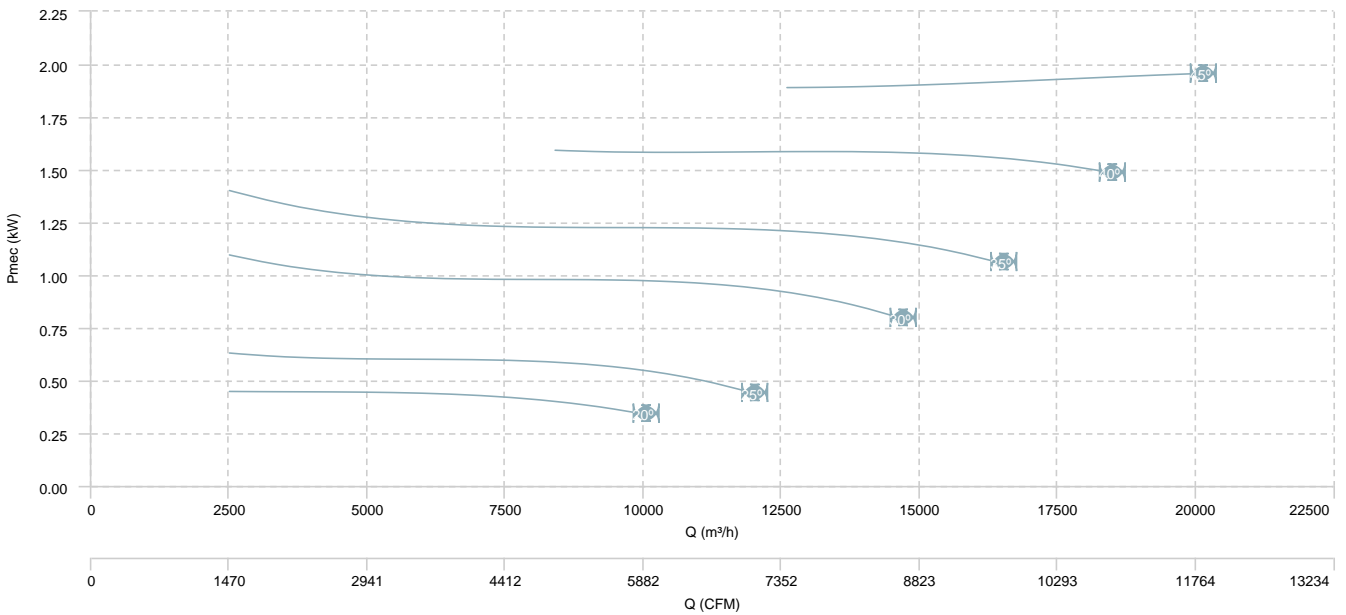

HCFX 63 T6 (A5:6) F400

**AIR FLOW - PRESSURE**

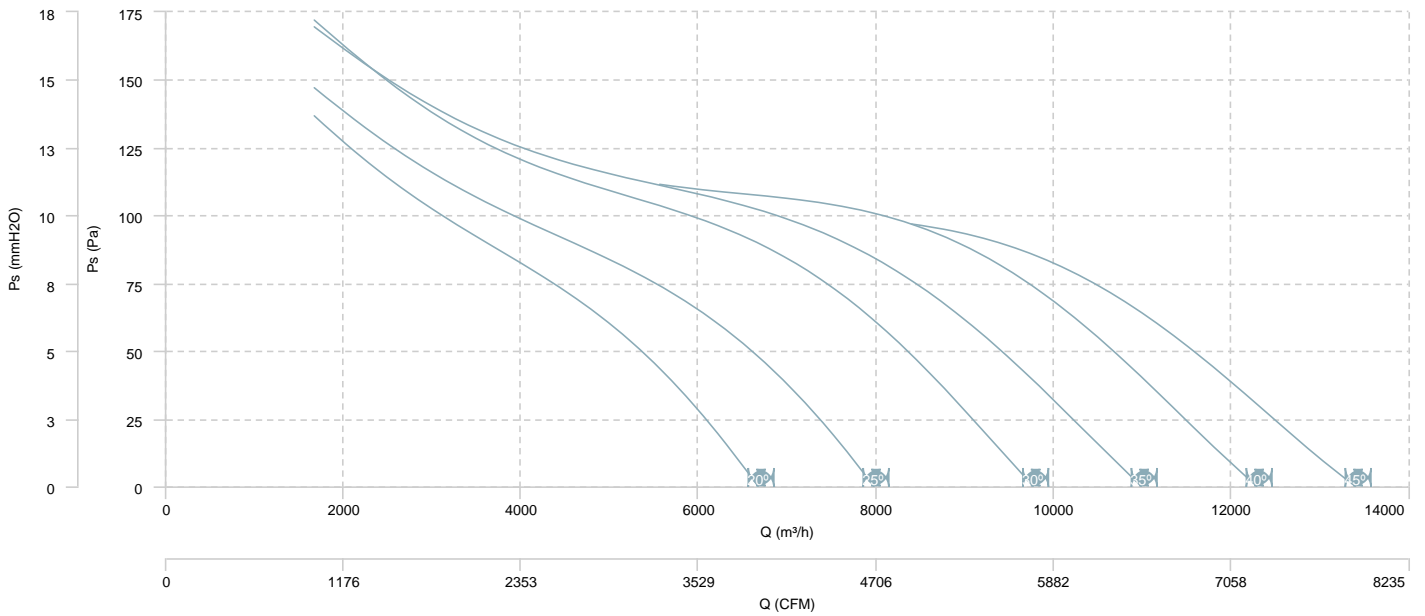

**AIR FLOW - MECHANICAL POWER**

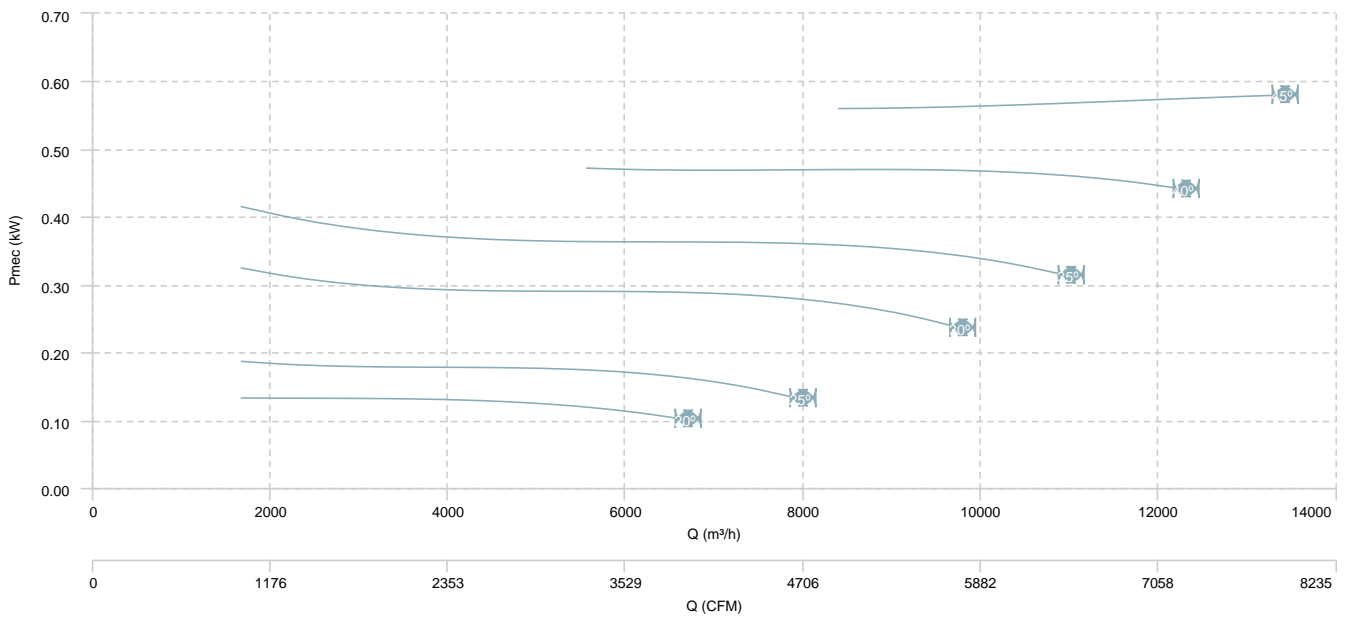

HCFX 63 T4/T8 (A5:6) F400

**AIR FLOW - PRESSURE (4 poles)**

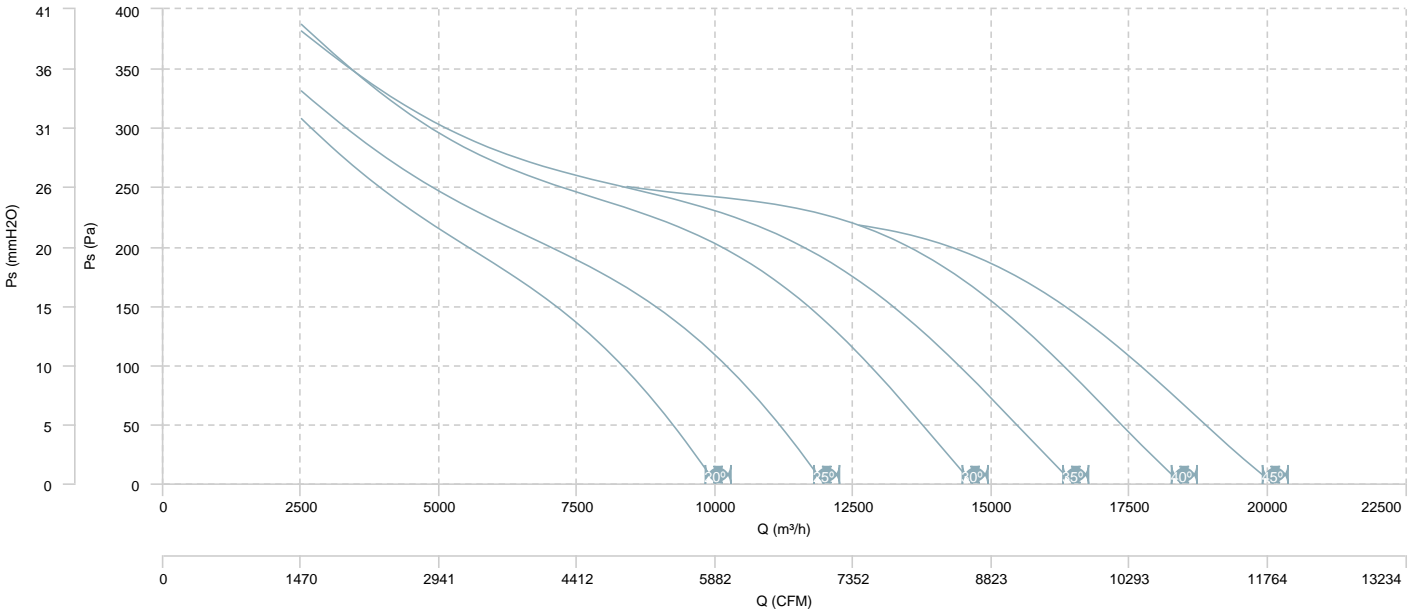

**AIR FLOW - MECHANICAL POWER (4 poles)**

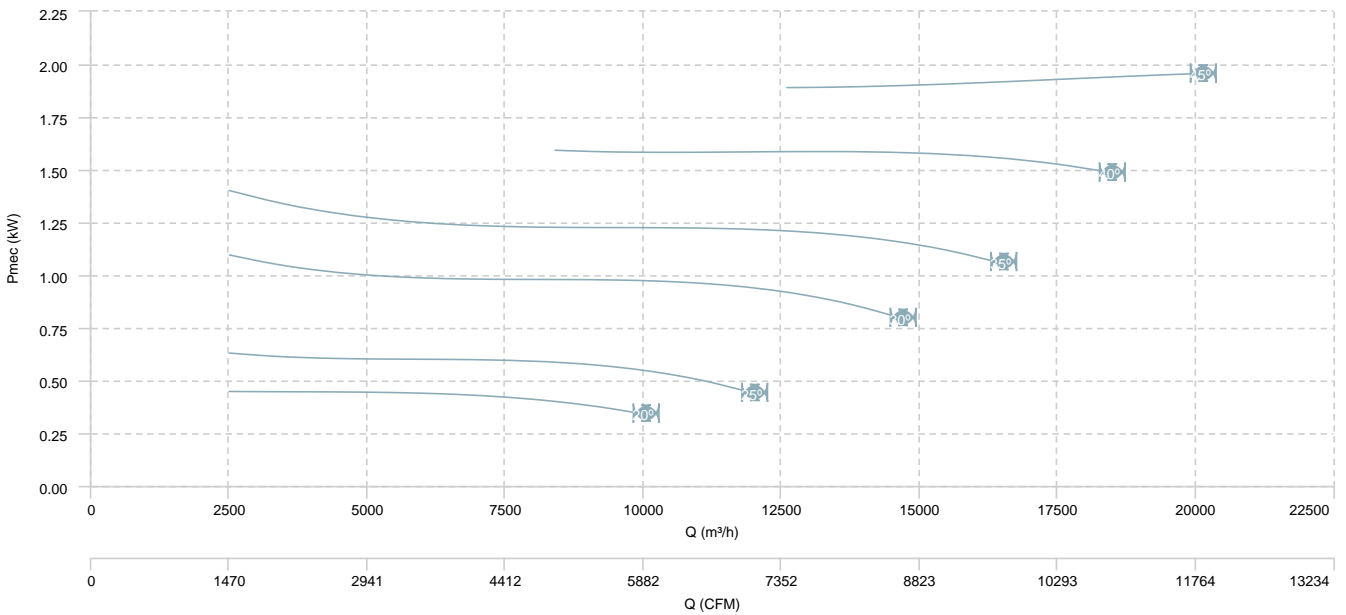

HCFX 63 T4/T8 (A5:6) F400

AIR FLOW - PRESSURE (8 poles)

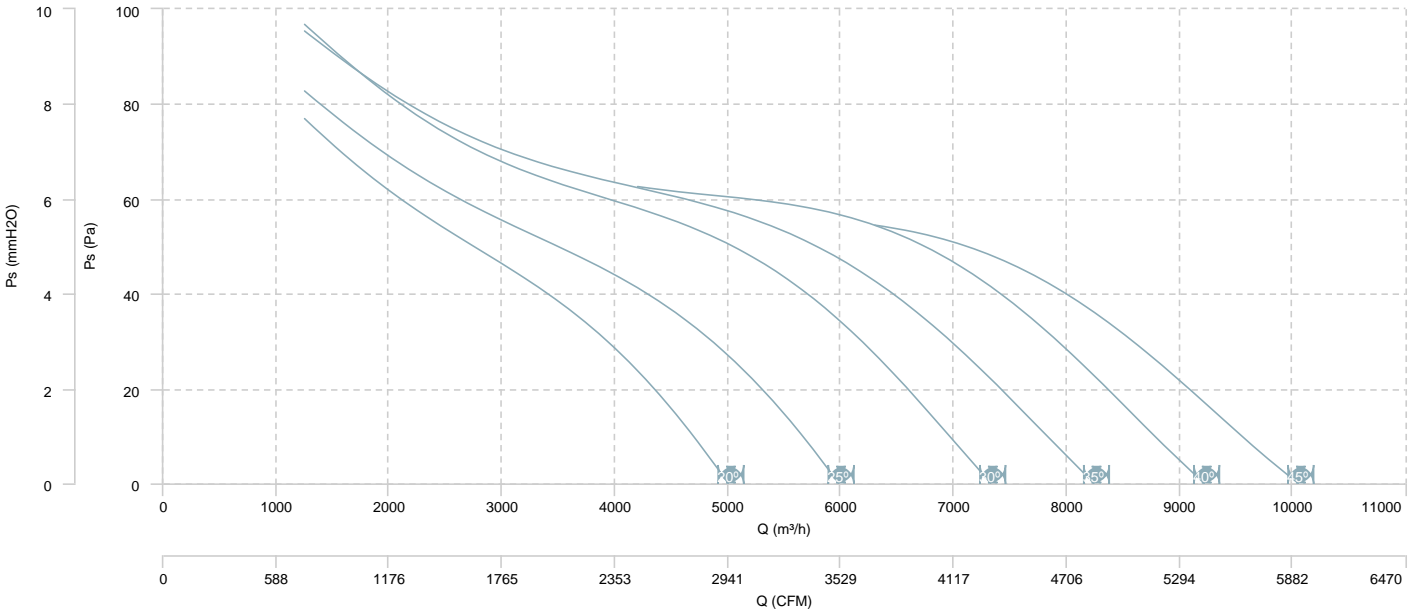

AIR FLOW - MECHANICAL POWER (8 poles)

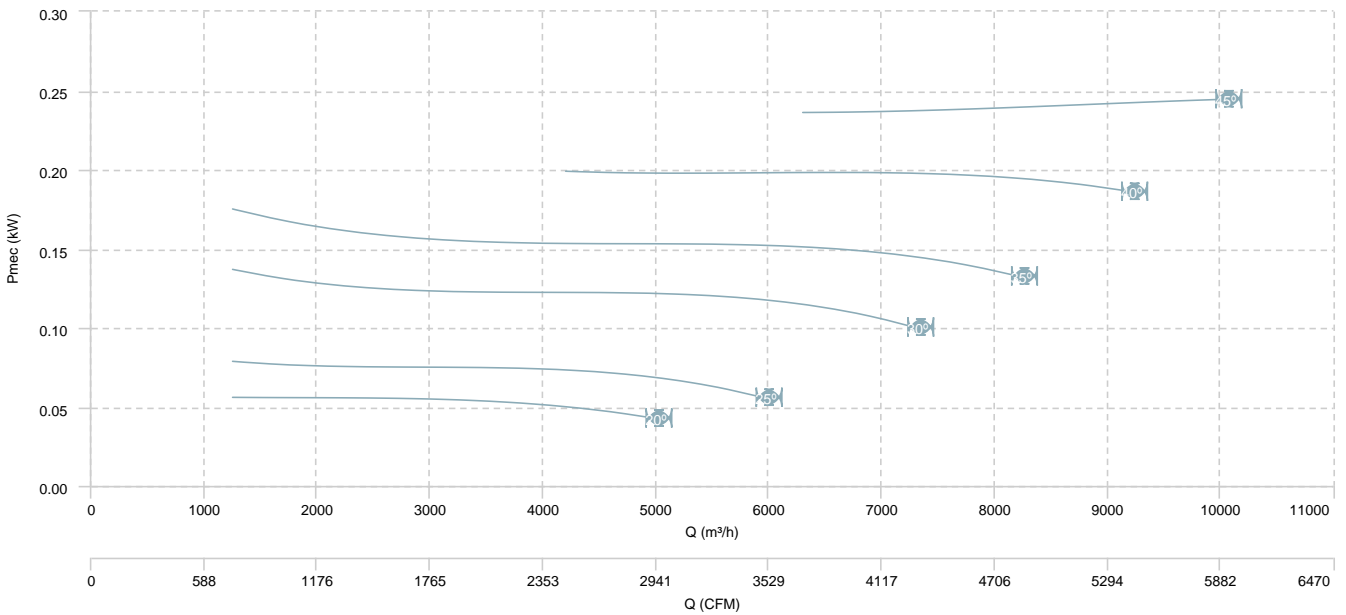



HCFX 71 T4 (A5:6) F400

**AIR FLOW - PRESSURE**

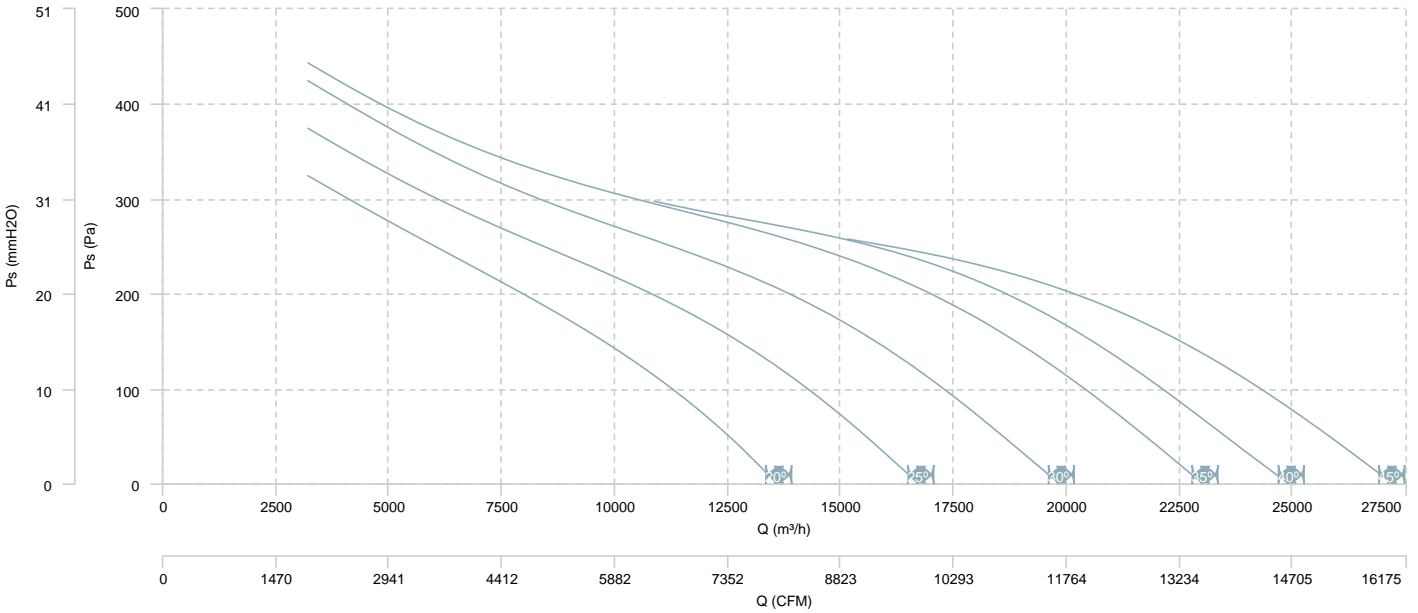

**AIR FLOW - MECHANICAL POWER**

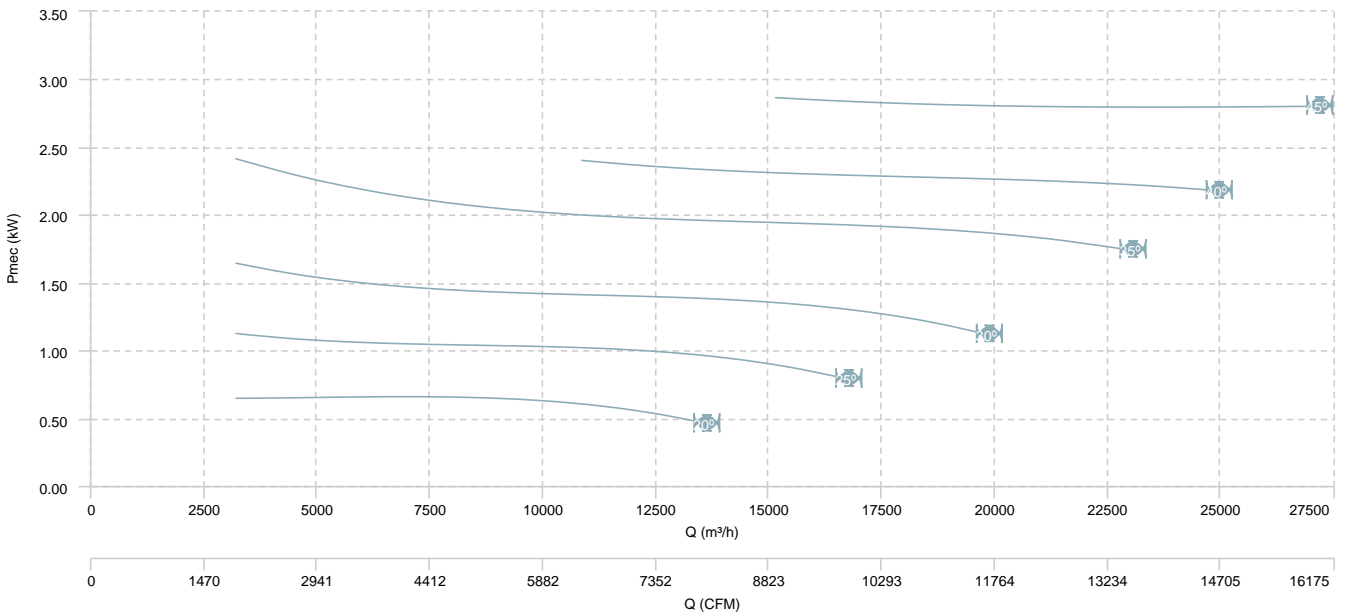

HCFX 71 T6 (A5:6) F400

**AIR FLOW - PRESSURE**

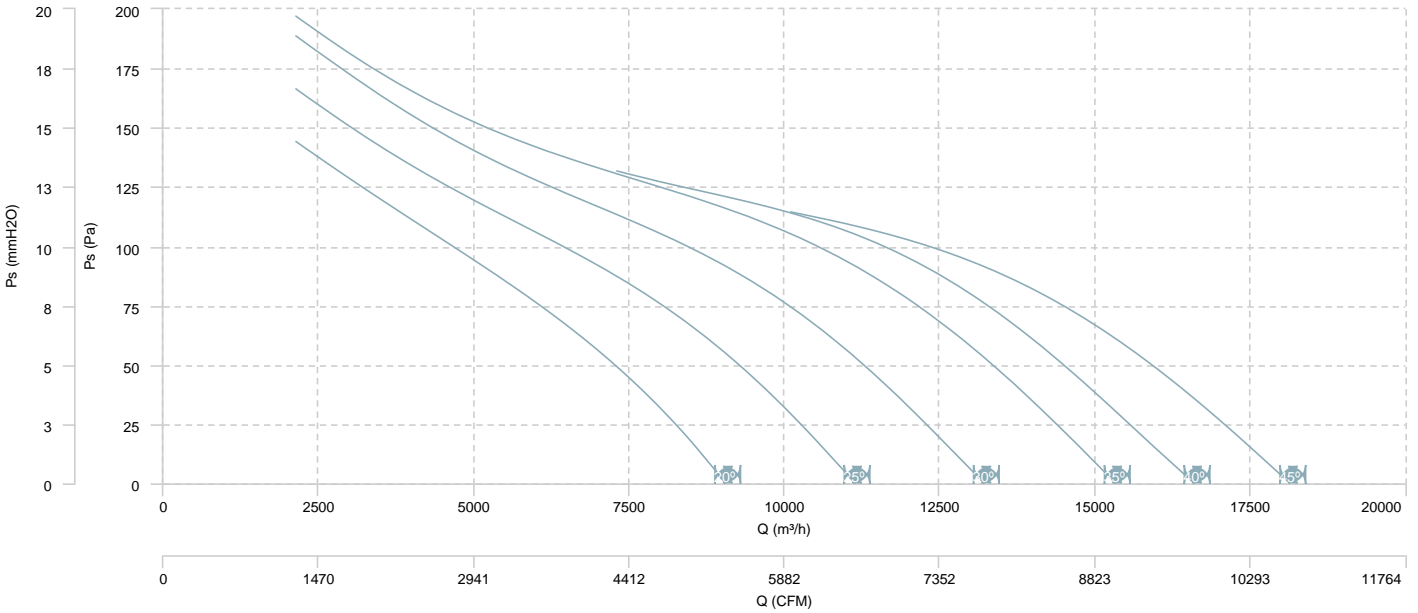

**AIR FLOW - MECHANICAL POWER**

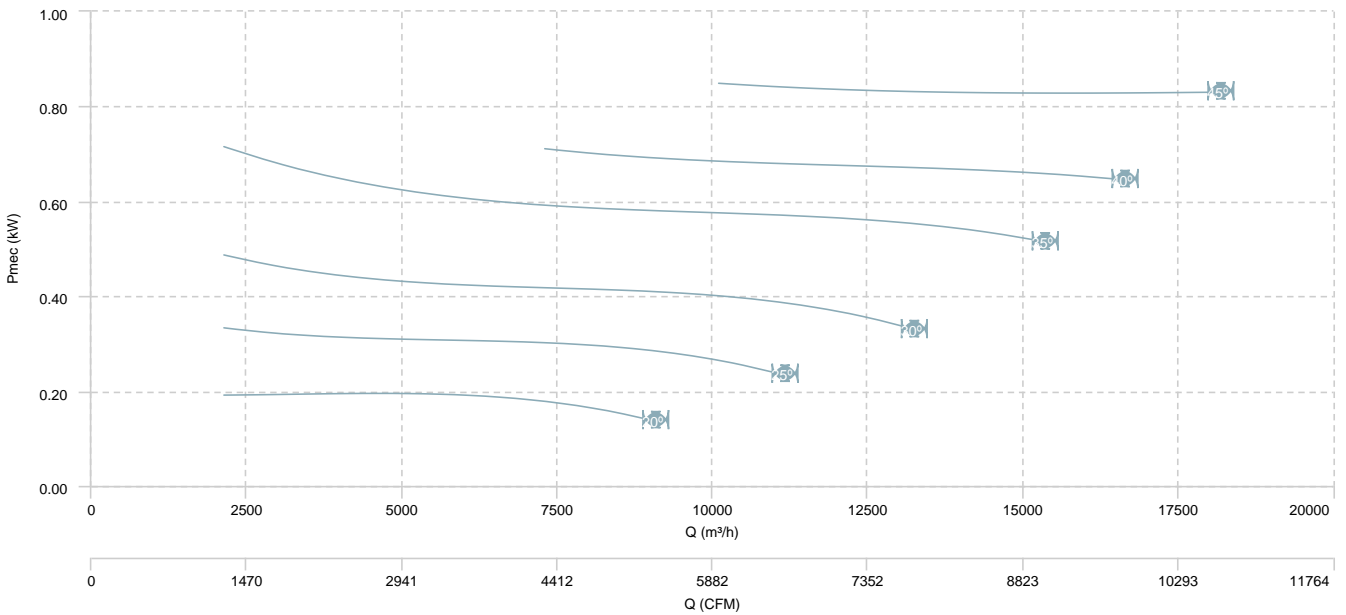

HCFX 71 T4/T8 (A5:6) F400

AIR FLOW - PRESSURE (4 poles)

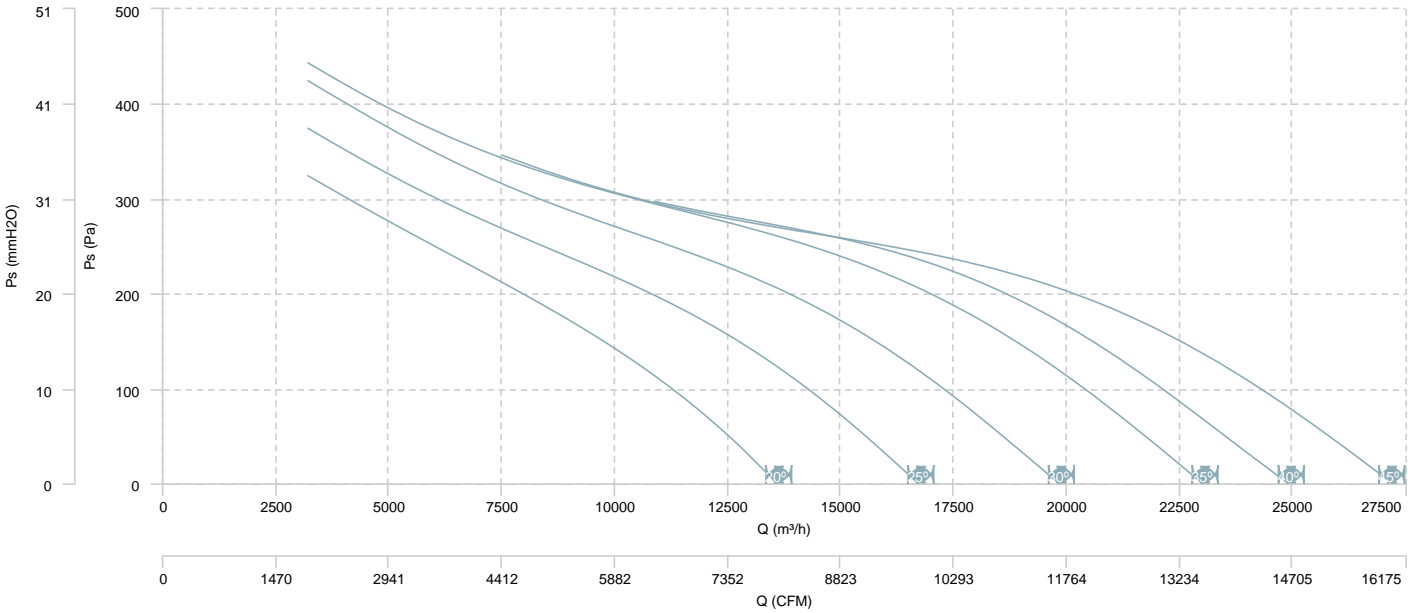

AIR FLOW - MECHANICAL POWER (4 poles)

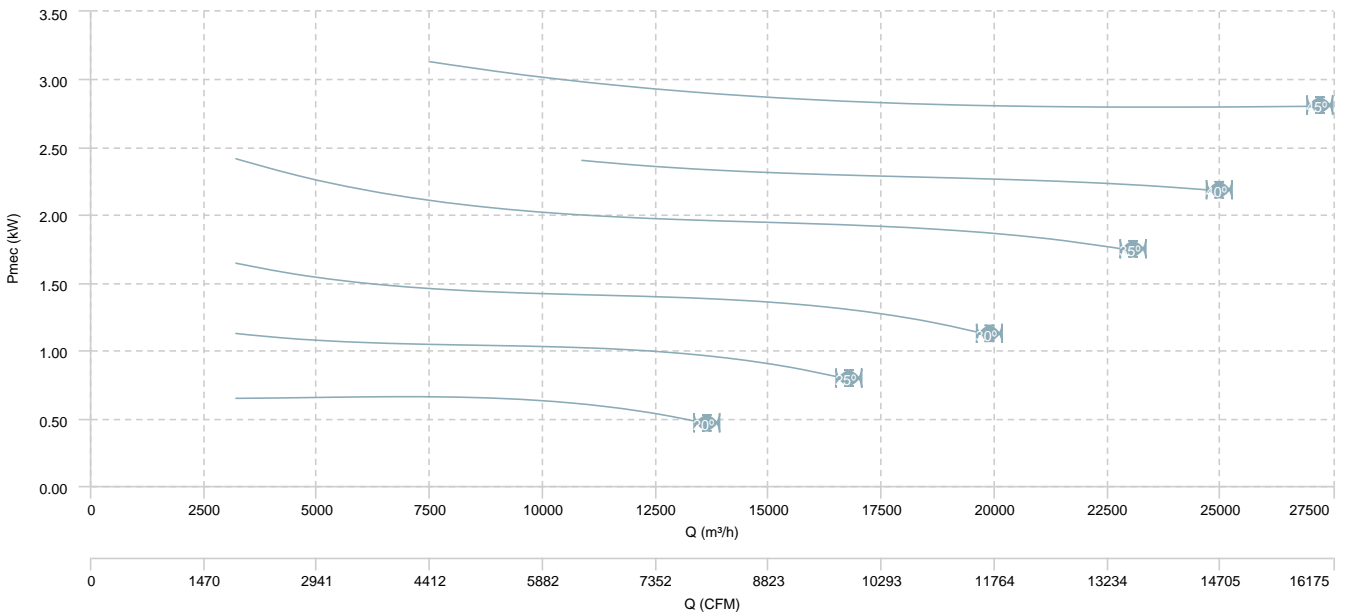

HCFX 71 T4/T8 (A5:6) F400

AIR FLOW - PRESSURE (8 poles)

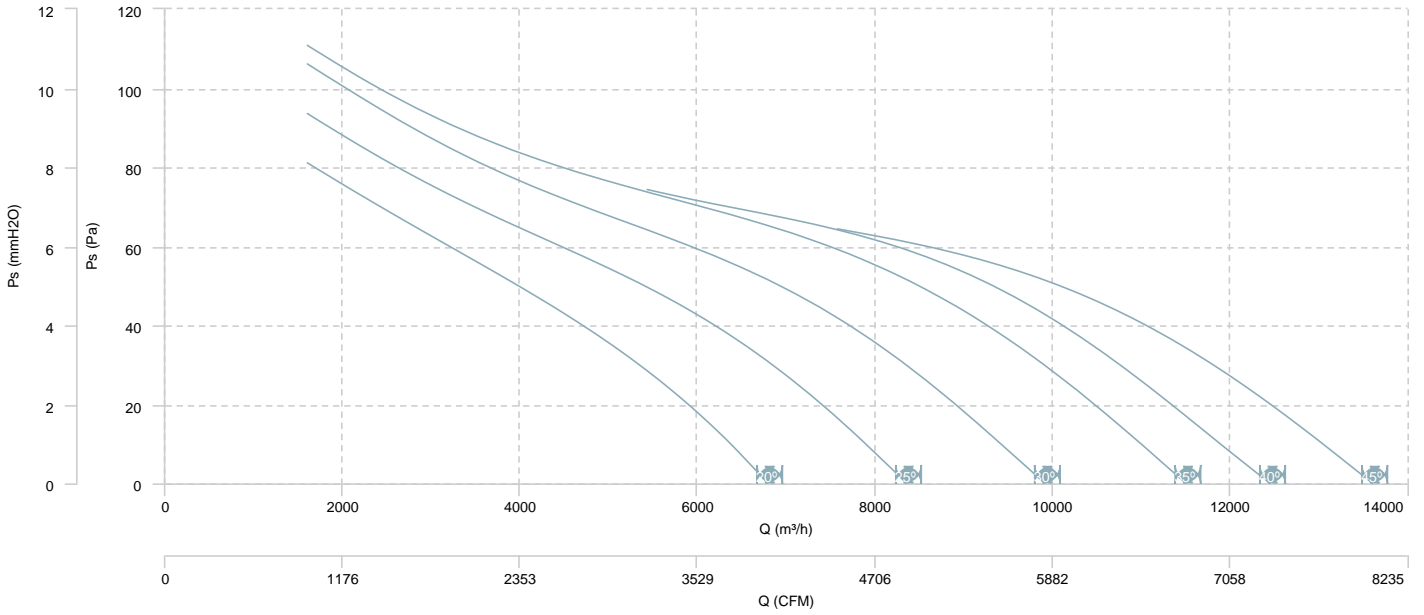

AIR FLOW - MECHANICAL POWER (8 poles)

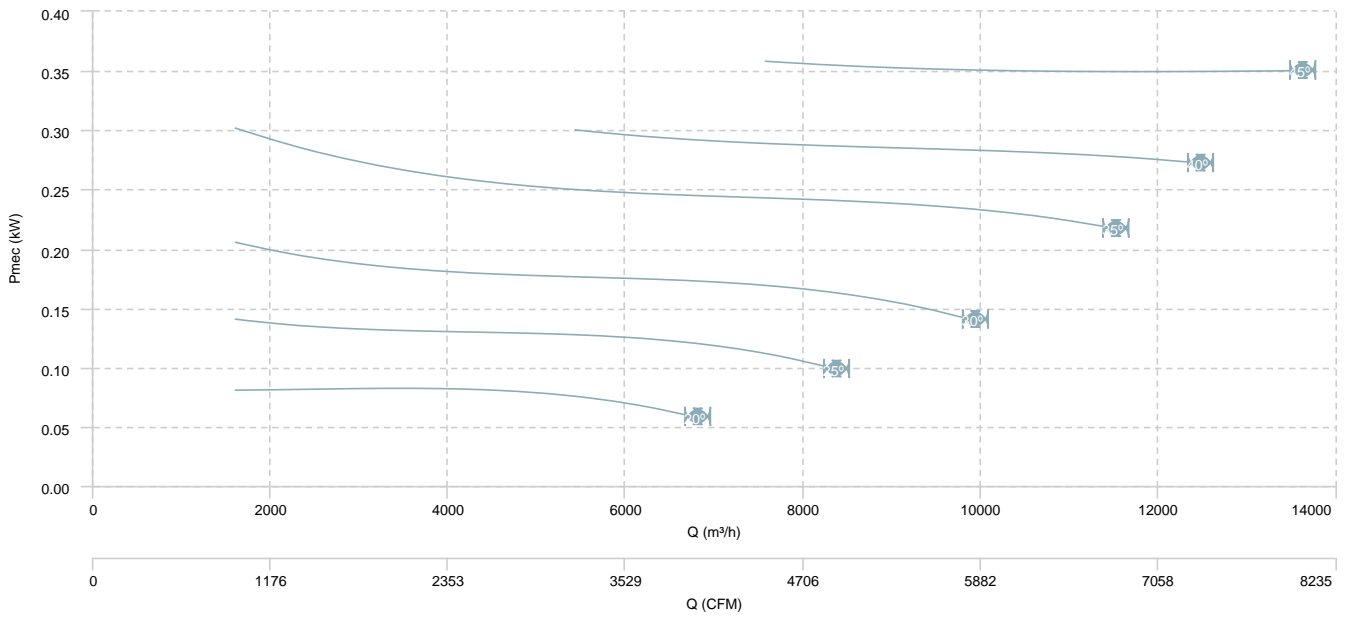

HCFX 80 T4 (A5:6) F400

**AIR FLOW - PRESSURE**

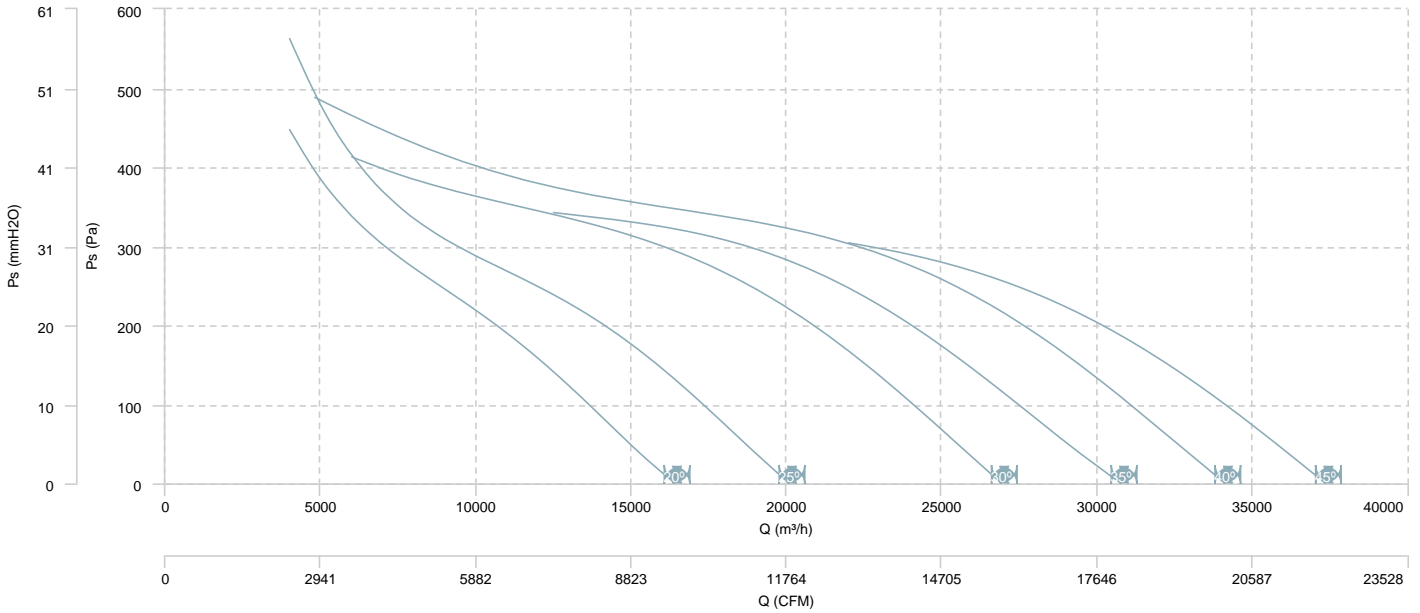

**AIR FLOW - MECHANICAL POWER**

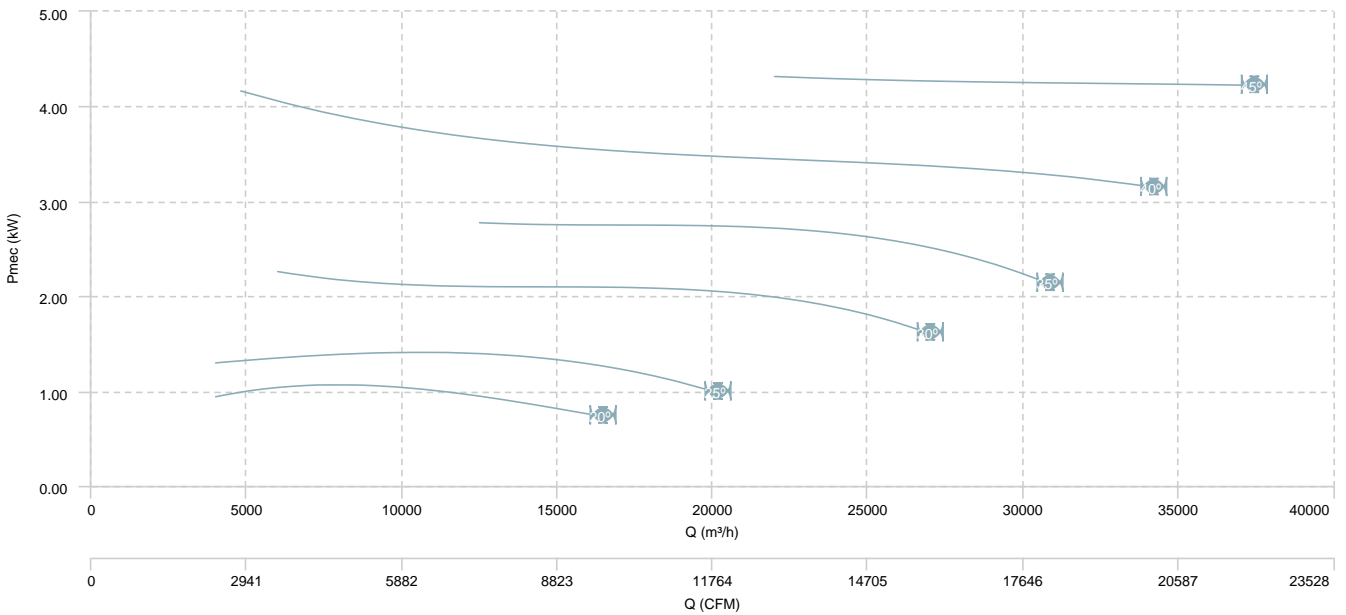

HCFX 80 T6 (A5:6) F400

**AIR FLOW - PRESSURE**

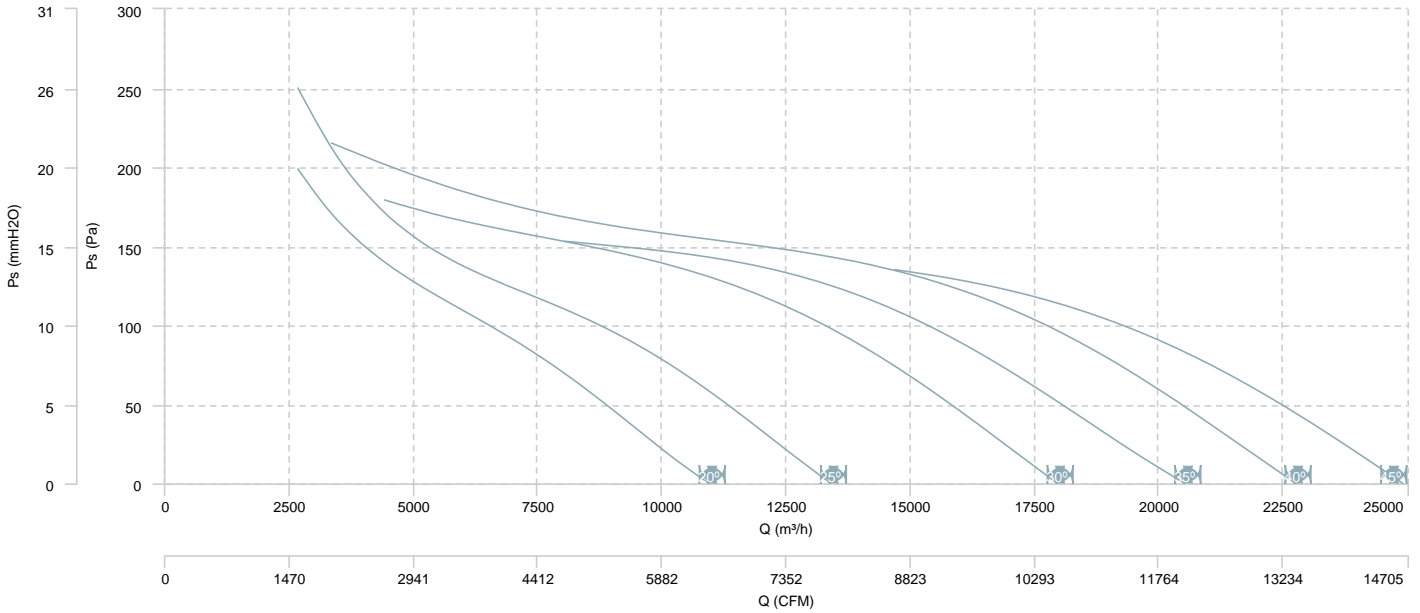

**AIR FLOW - MECHANICAL POWER**

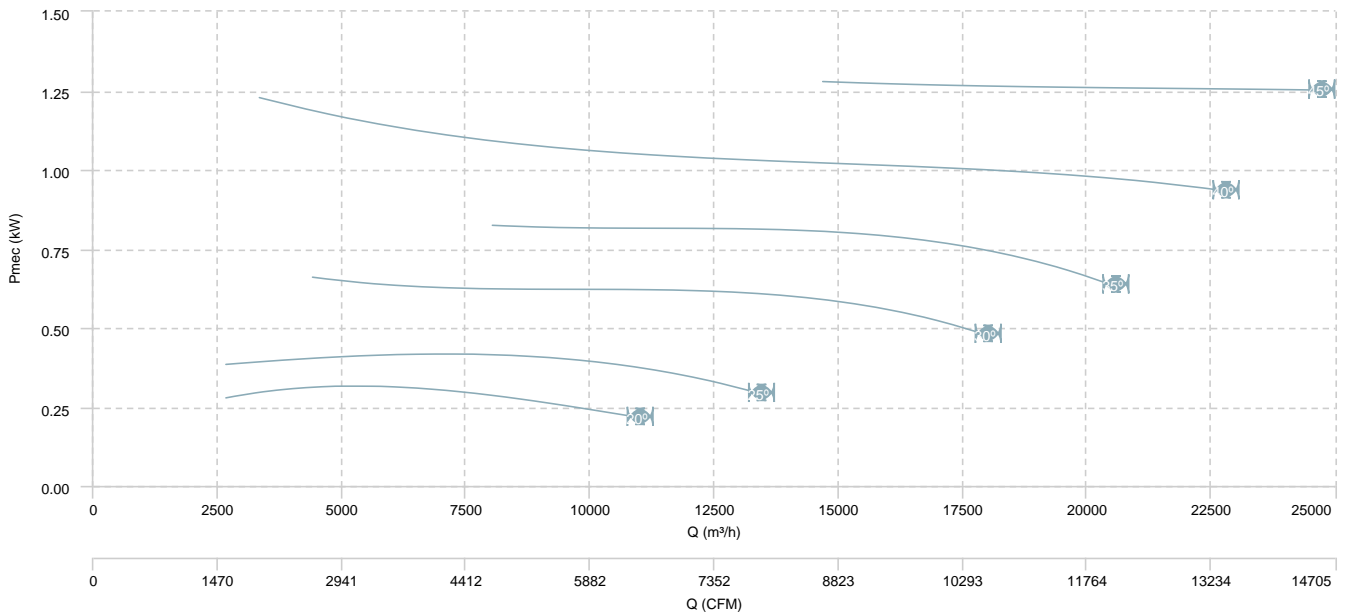

HCFX 80 T4/T8 (A5:6) F400

**AIR FLOW - PRESSURE (4 poles)**

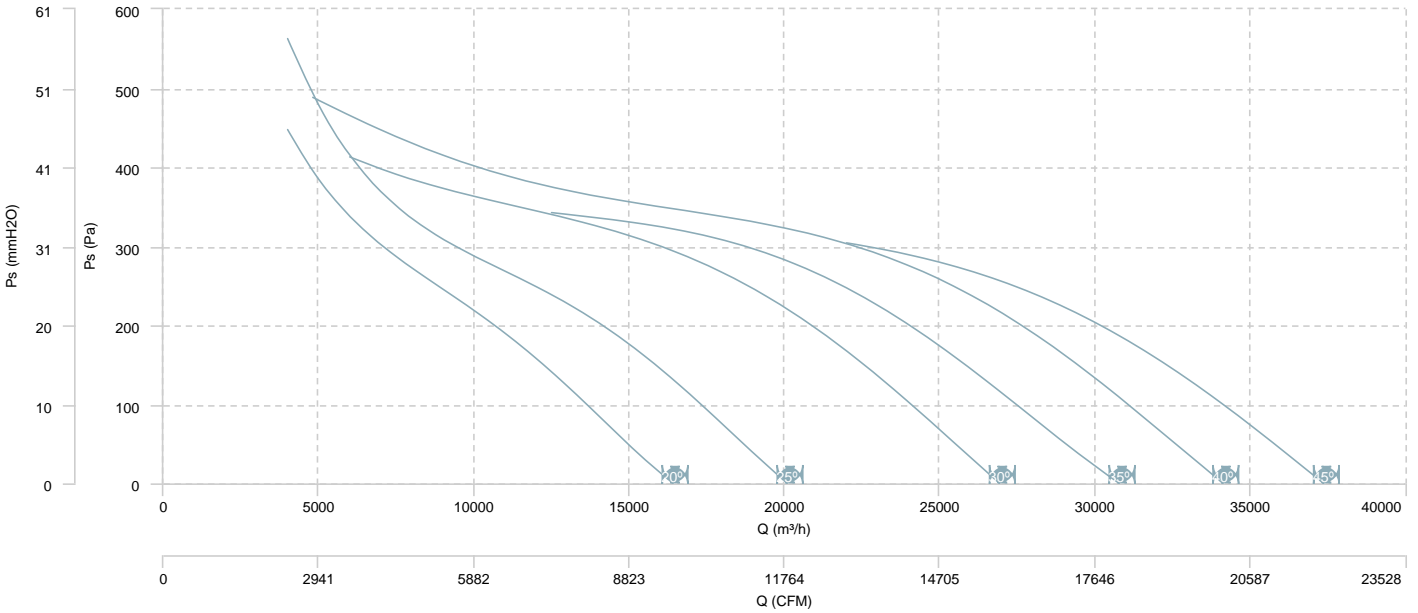

**AIR FLOW - MECHANICAL POWER (4 poles)**

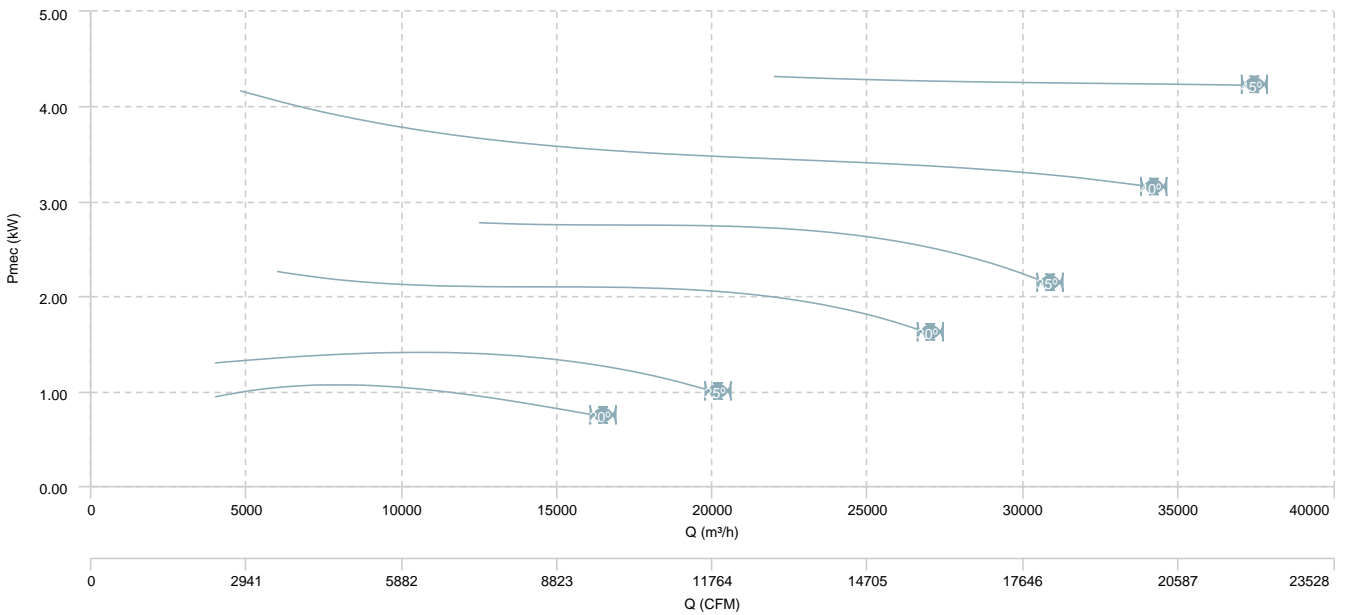

HCFX 80 T4/T8 (A5:6) F400

**AIR FLOW - PRESSURE (8 poles)**

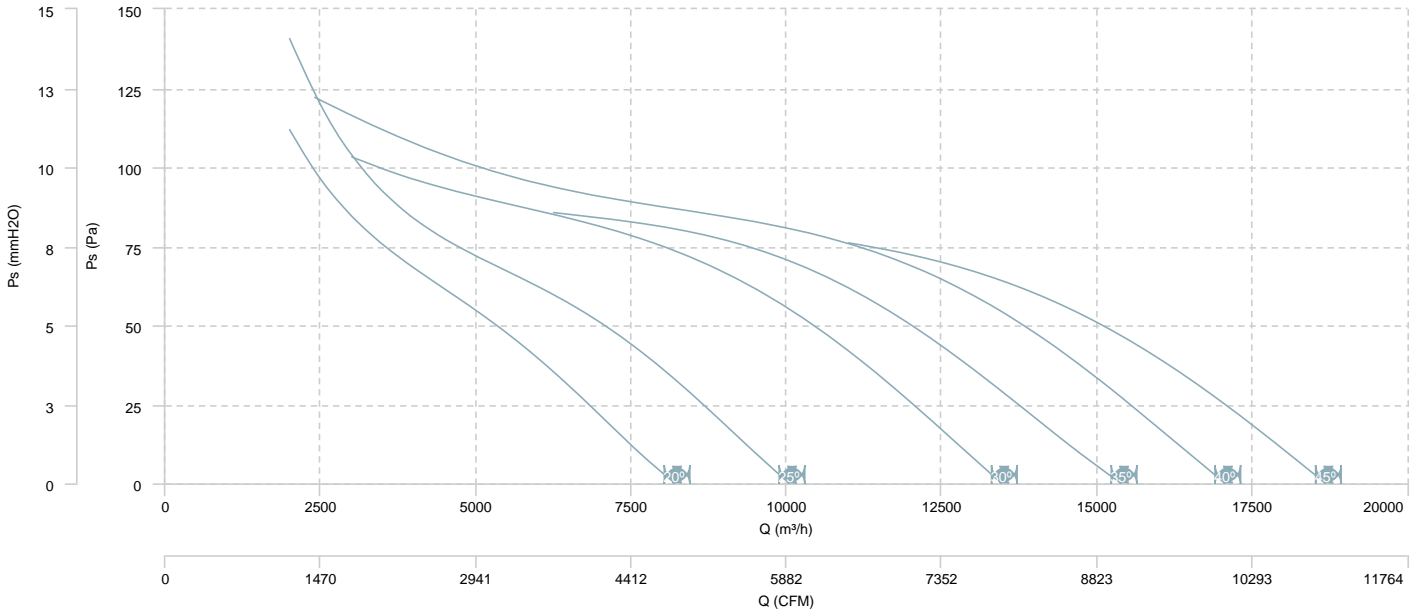

**AIR FLOW - MECHANICAL POWER (8 poles)**

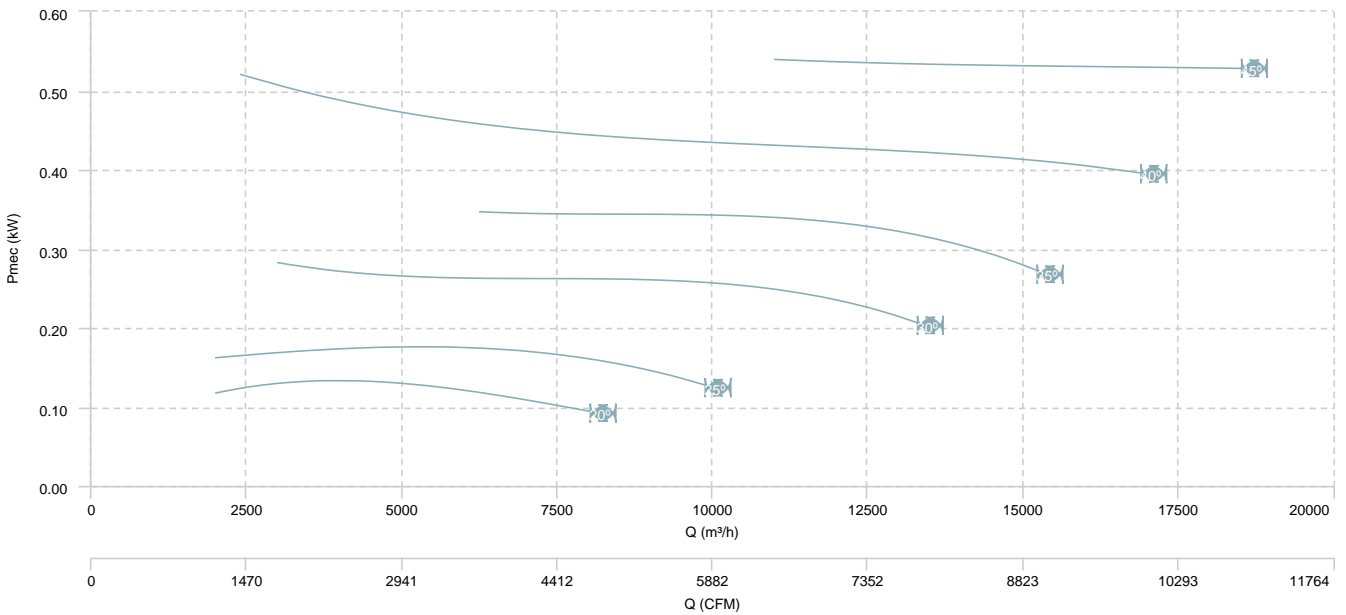



HCFX 90 T4 (A3:4) F400

**AIR FLOW - PRESSURE**

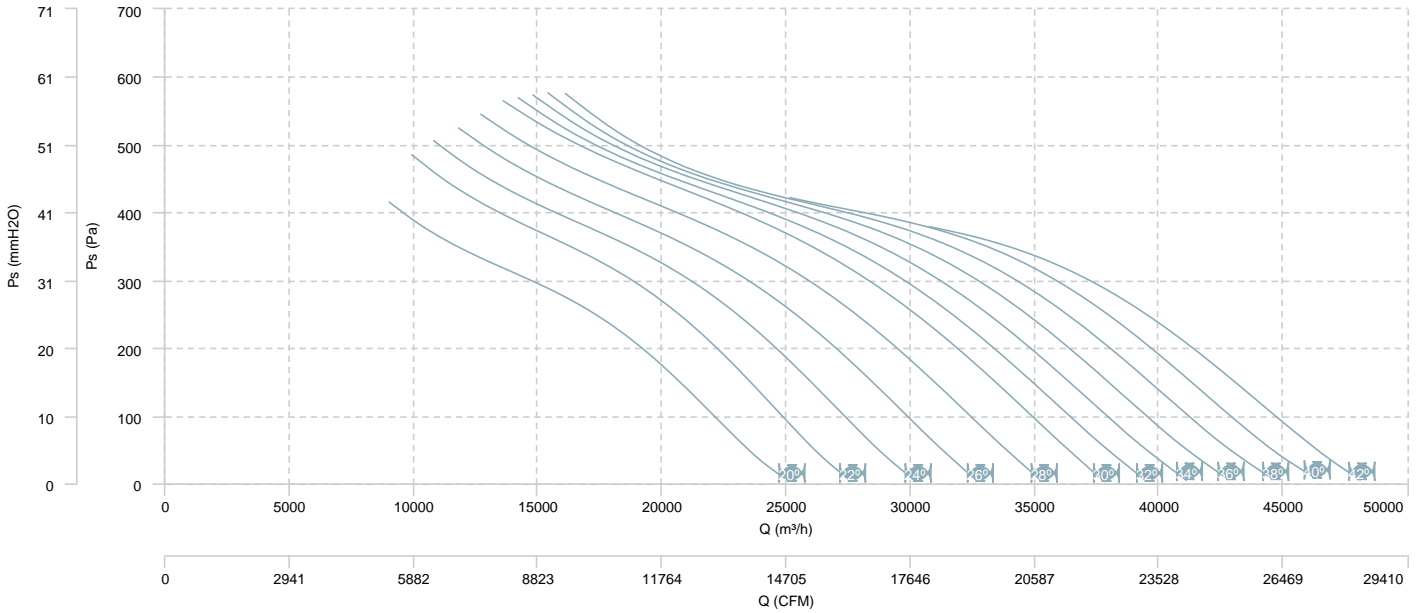

**AIR FLOW - MECHANICAL POWER**

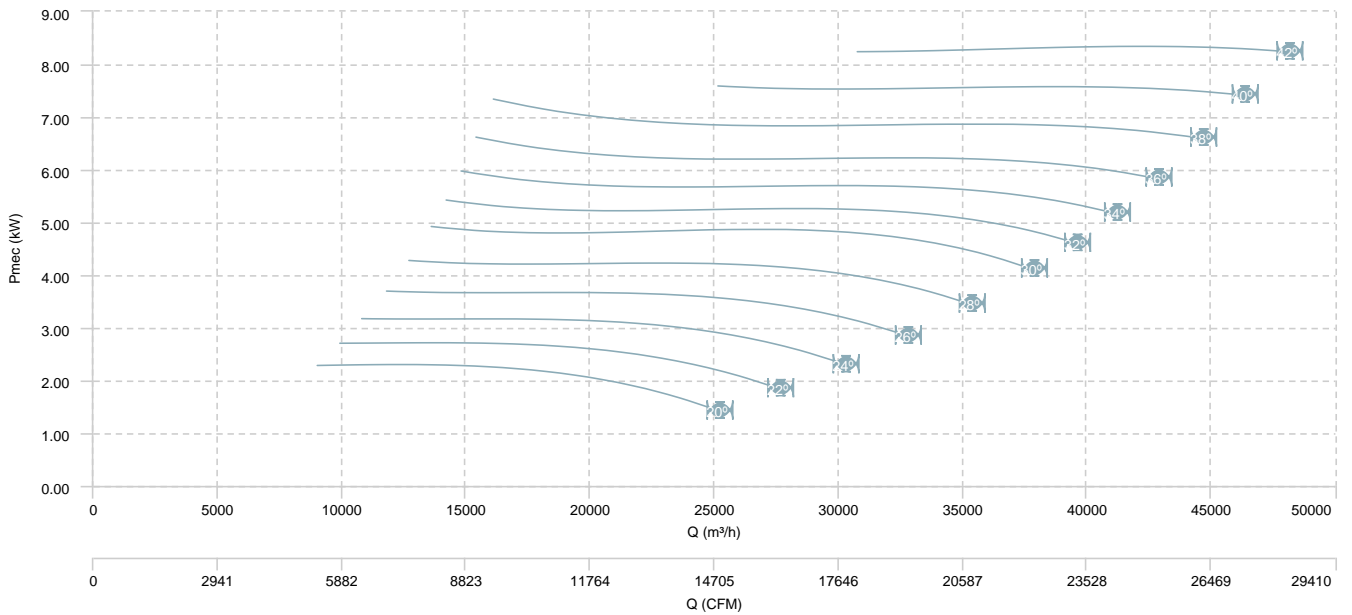

HCFX 90 T4 (A3:8) F400

**AIR FLOW - PRESSURE**

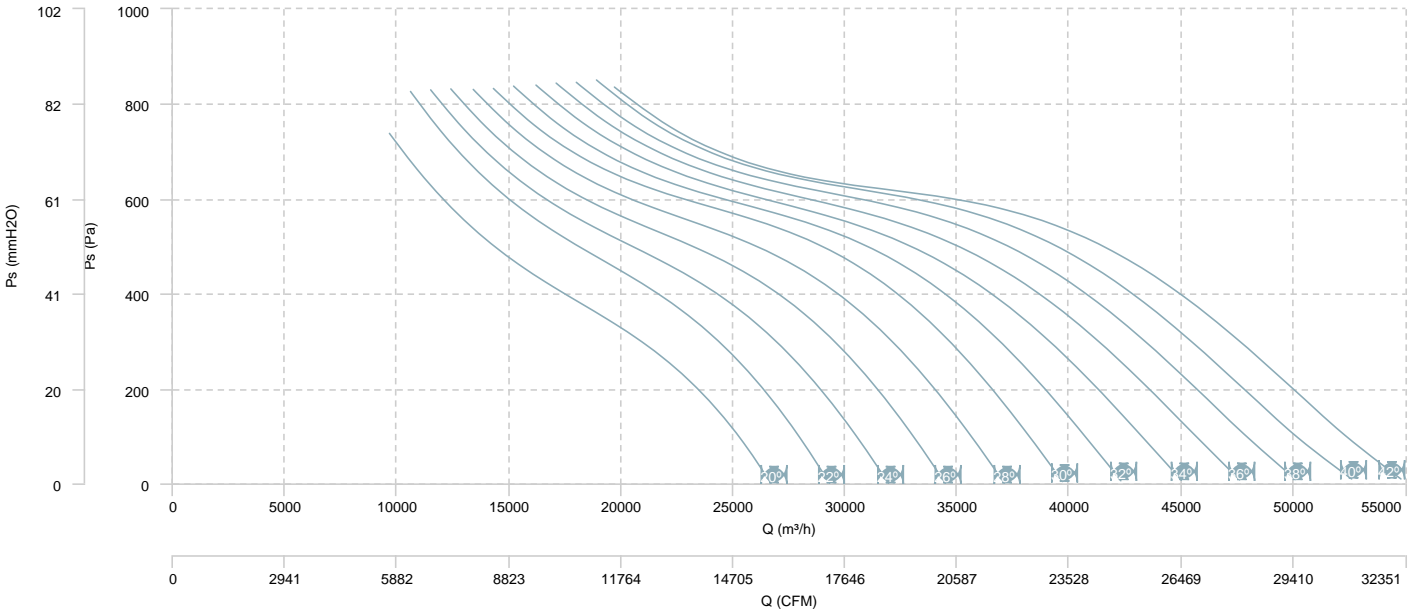

**AIR FLOW - MECHANICAL POWER**

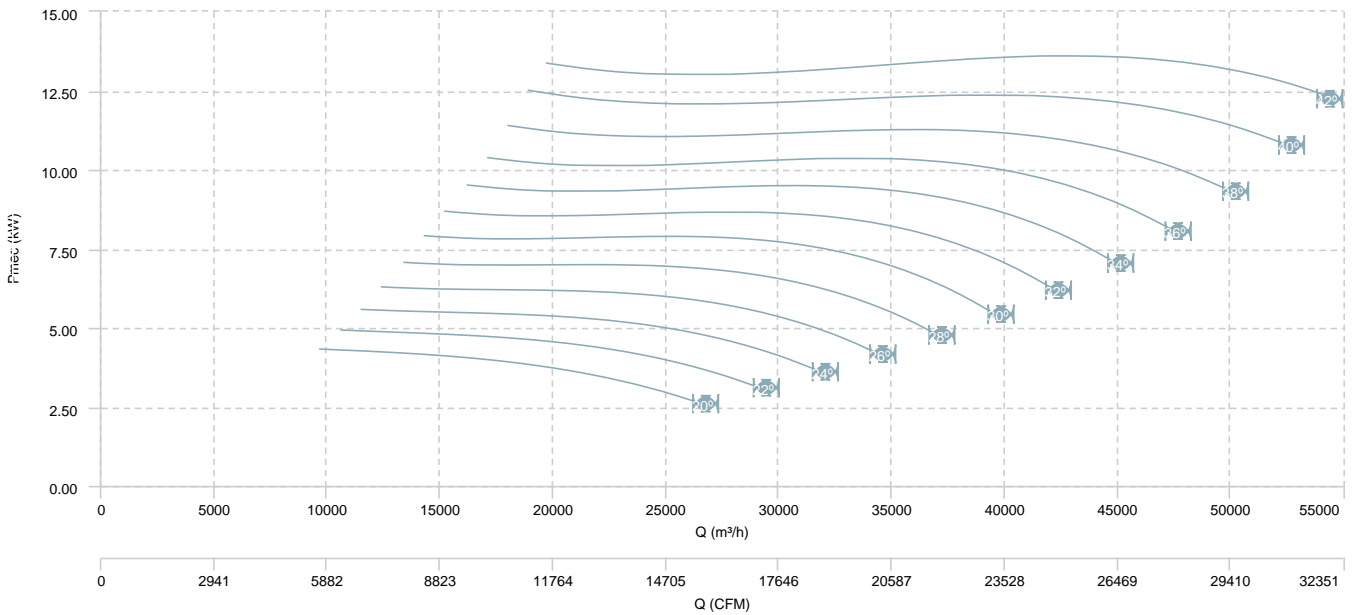

HCFX 90 T6 (A3:4) F400

**AIR FLOW - PRESSURE**

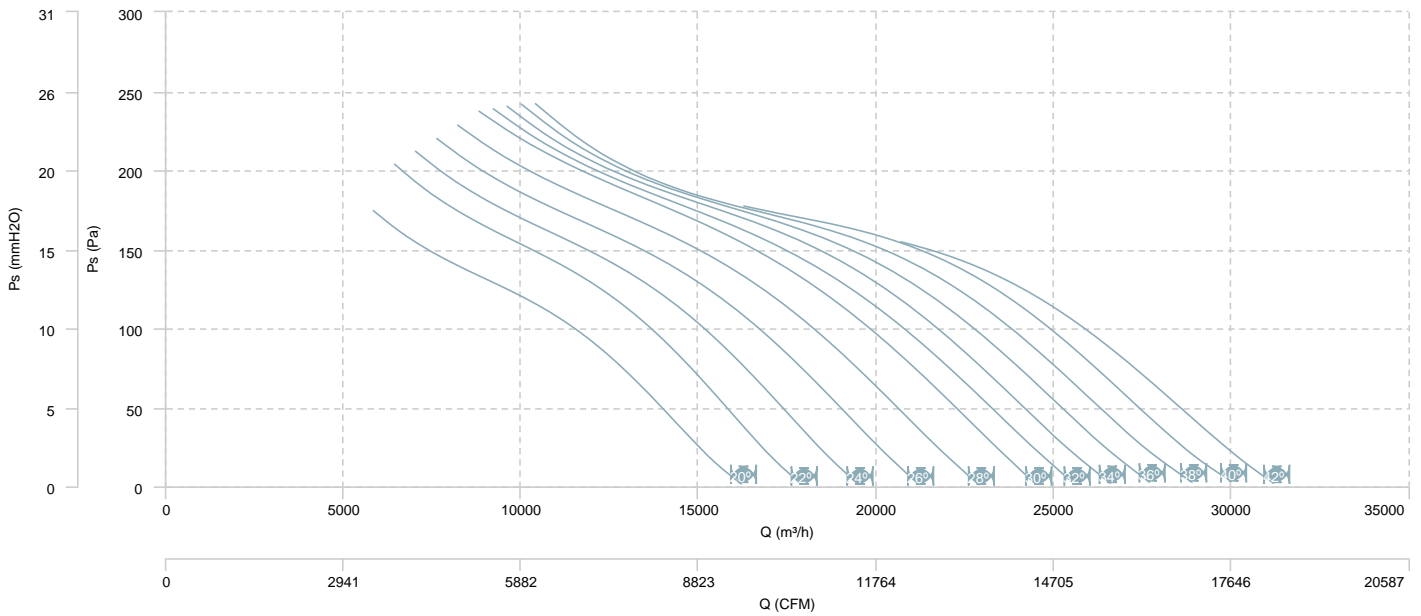

**AIR FLOW - MECHANICAL POWER**

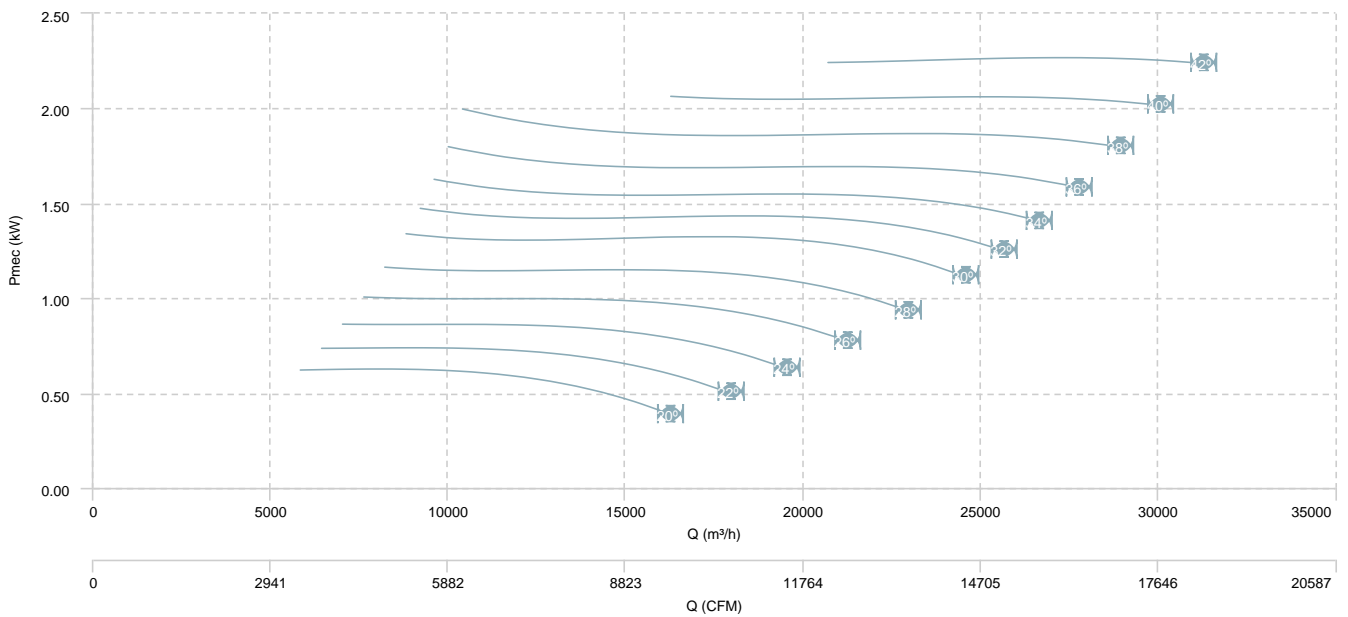

HCFX 90 T6 (A3:8) F400

**AIR FLOW - PRESSURE**

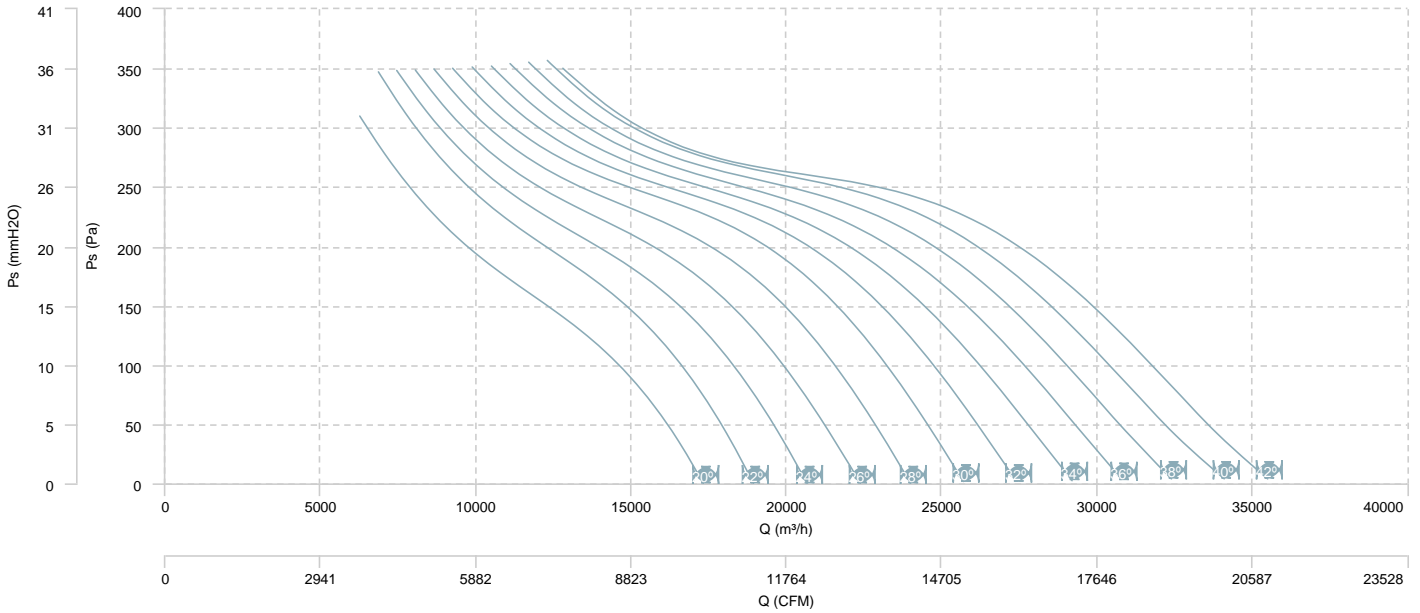

**AIR FLOW - MECHANICAL POWER**

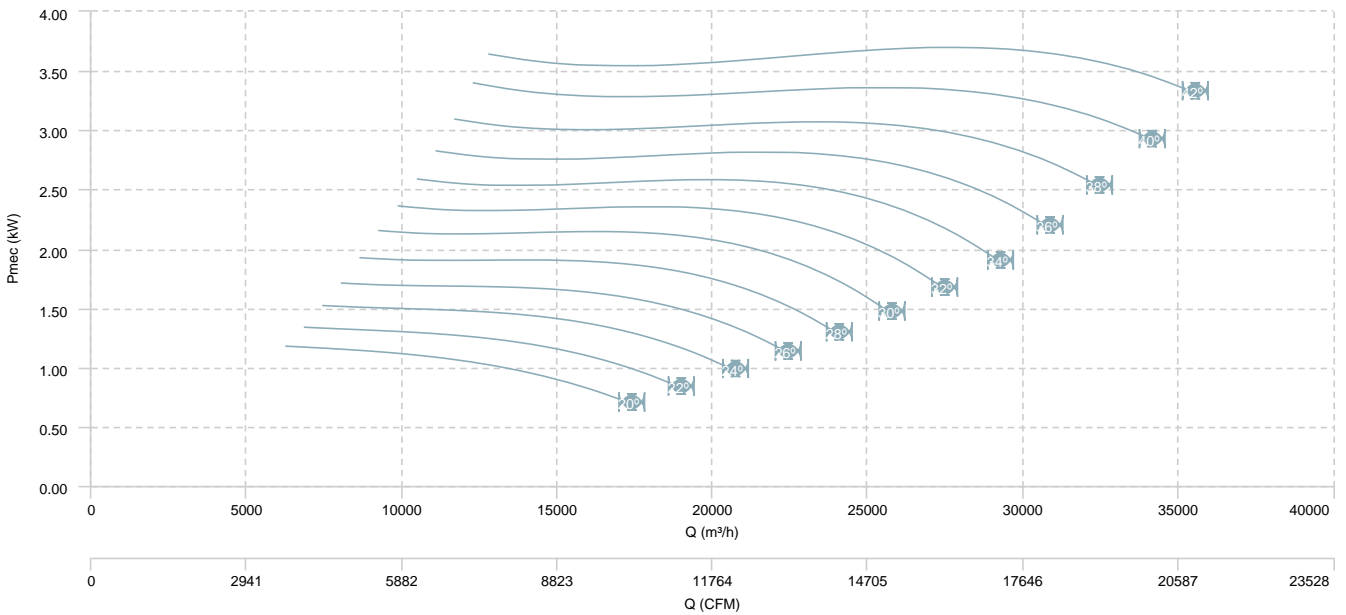

HCFX 90 T4/T8 (A3:4) F400

**AIR FLOW - PRESSURE (4 poles)**

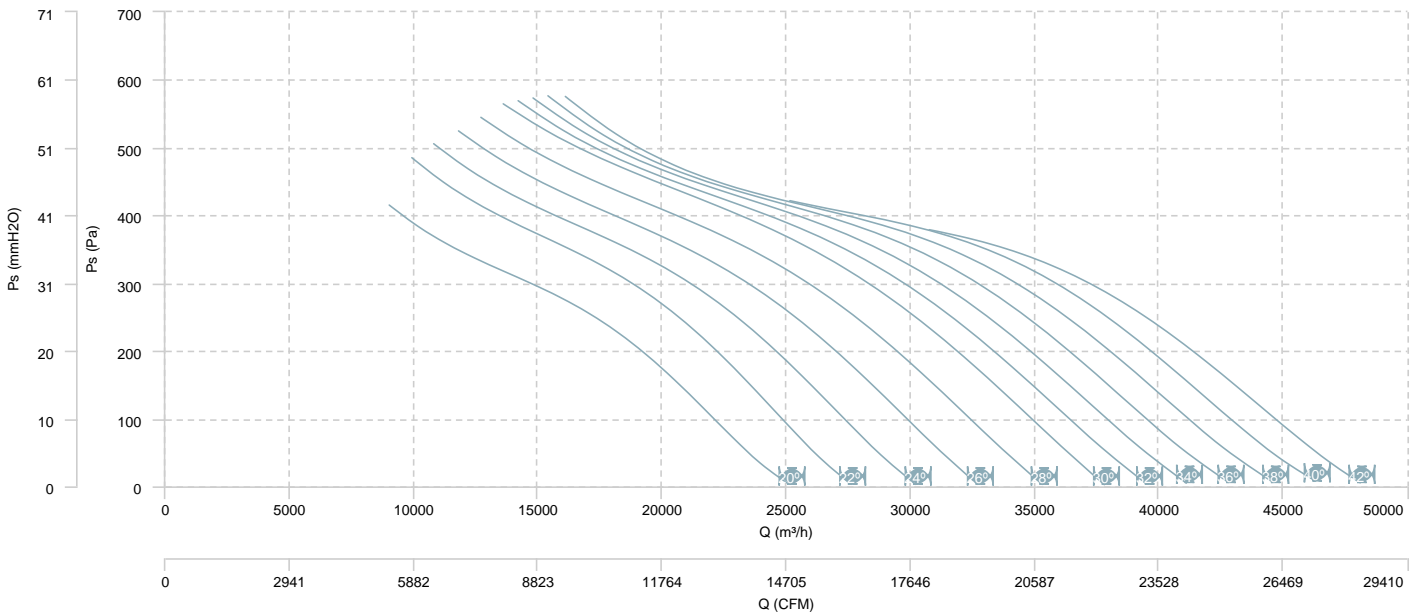

**AIR FLOW - MECHANICAL POWER (4 poles)**

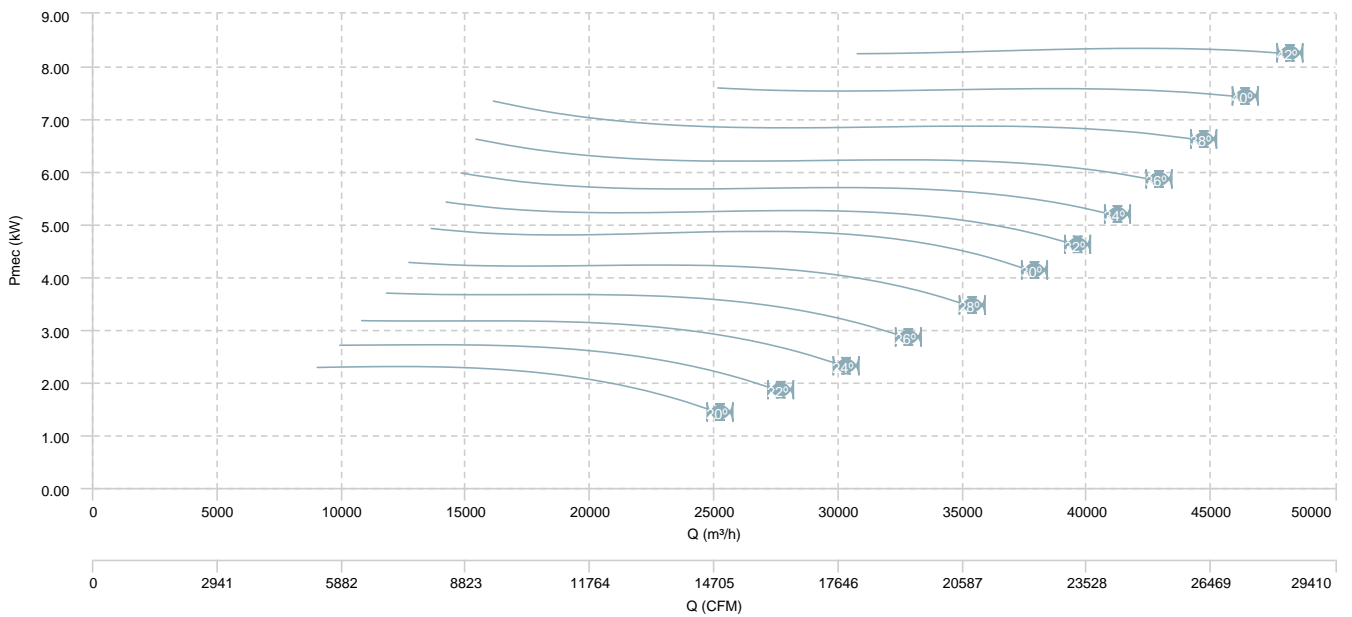

HCFX 90 T4/T8 (A3:4) F400

**AIR FLOW - PRESSURE (8 poles)**

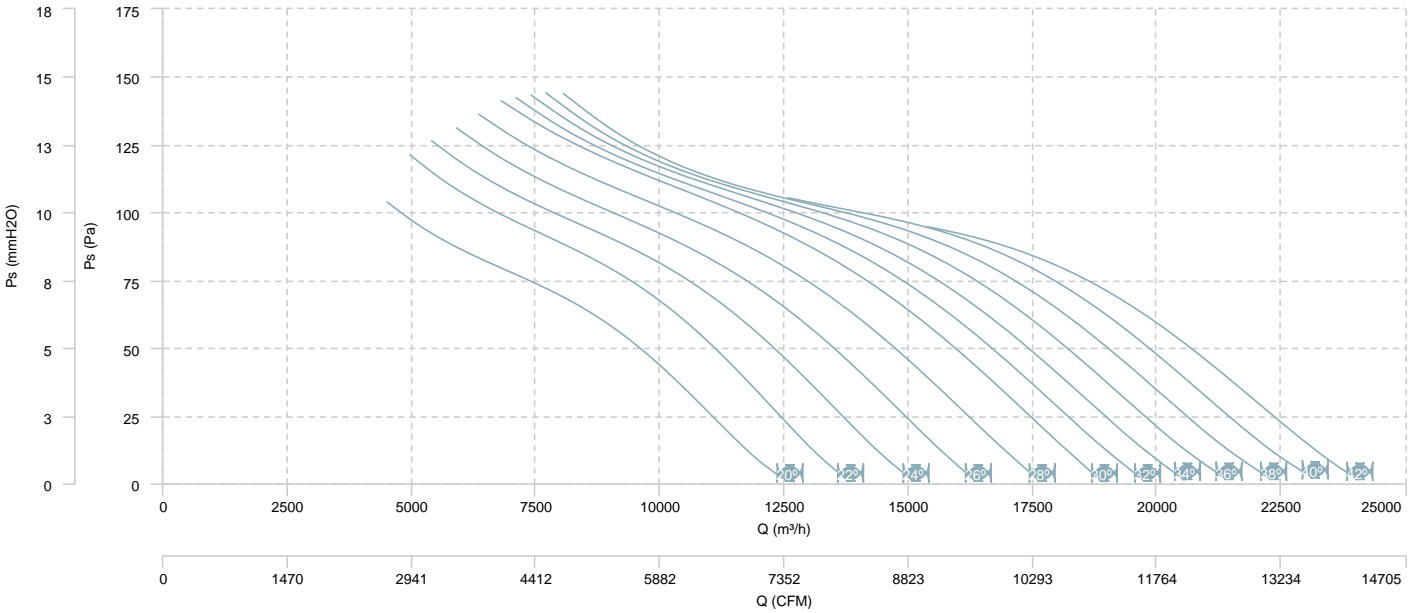

**AIR FLOW - MECHANICAL POWER (8 poles)**

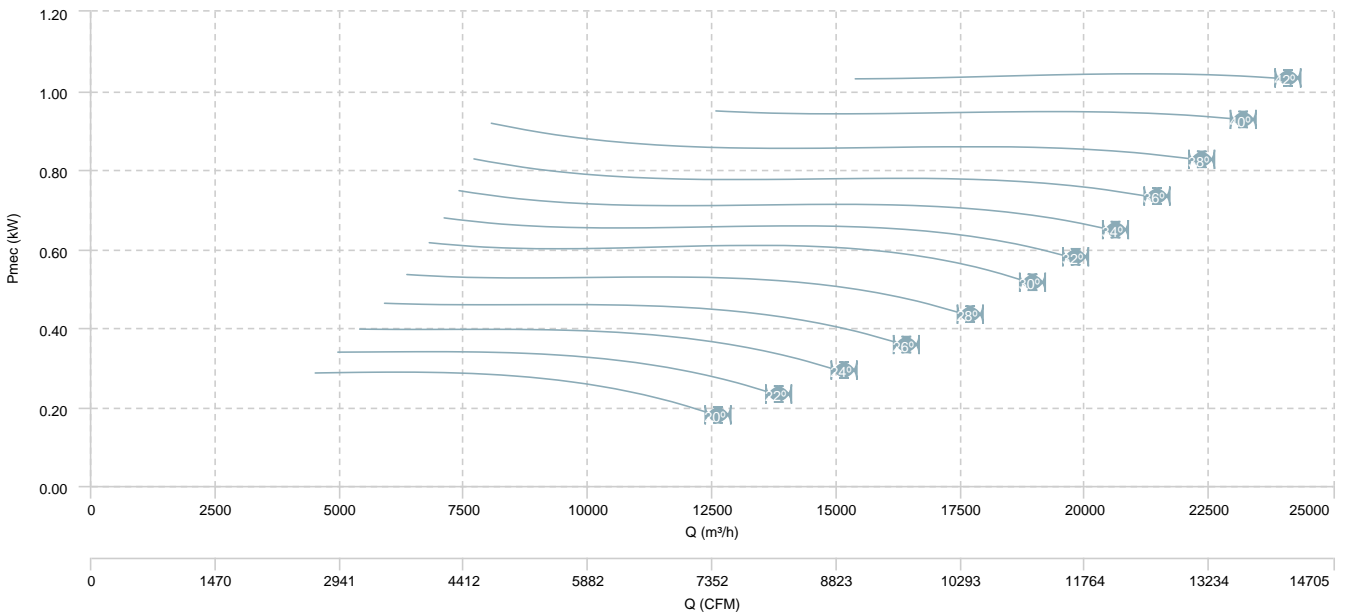

HCFX 90 T4/T8 (A3:8) F400

**AIR FLOW - PRESSURE (4 poles)**

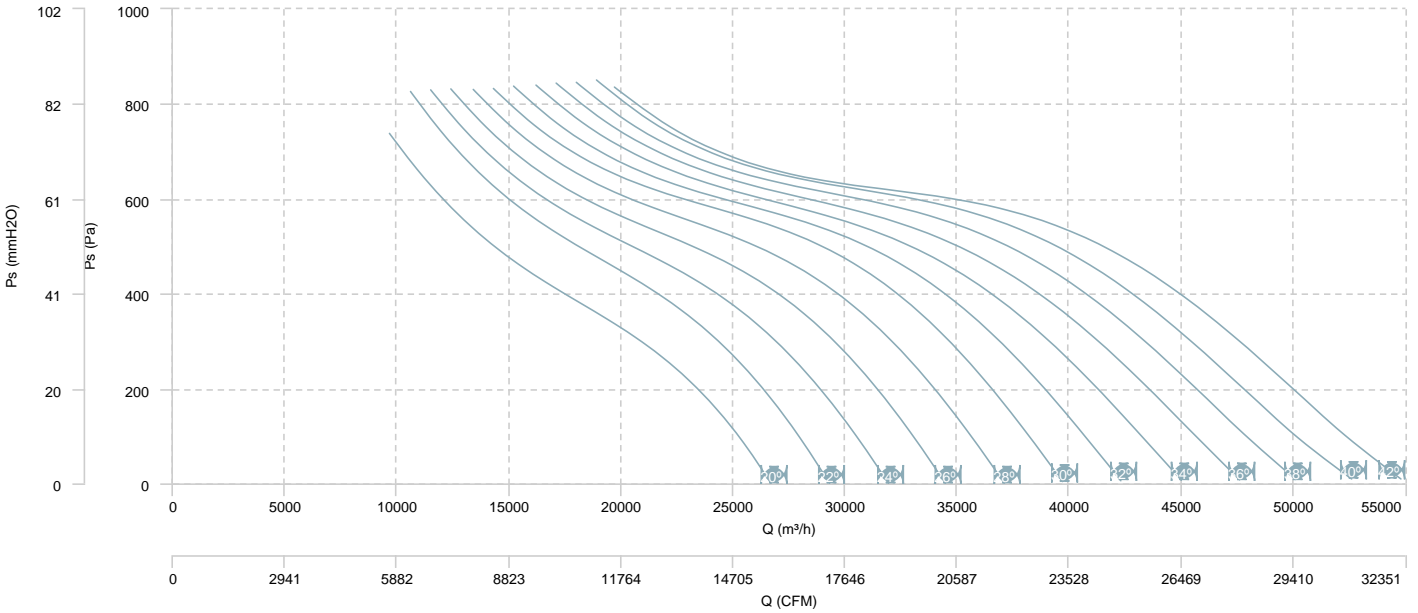

**AIR FLOW - MECHANICAL POWER (4 poles)**

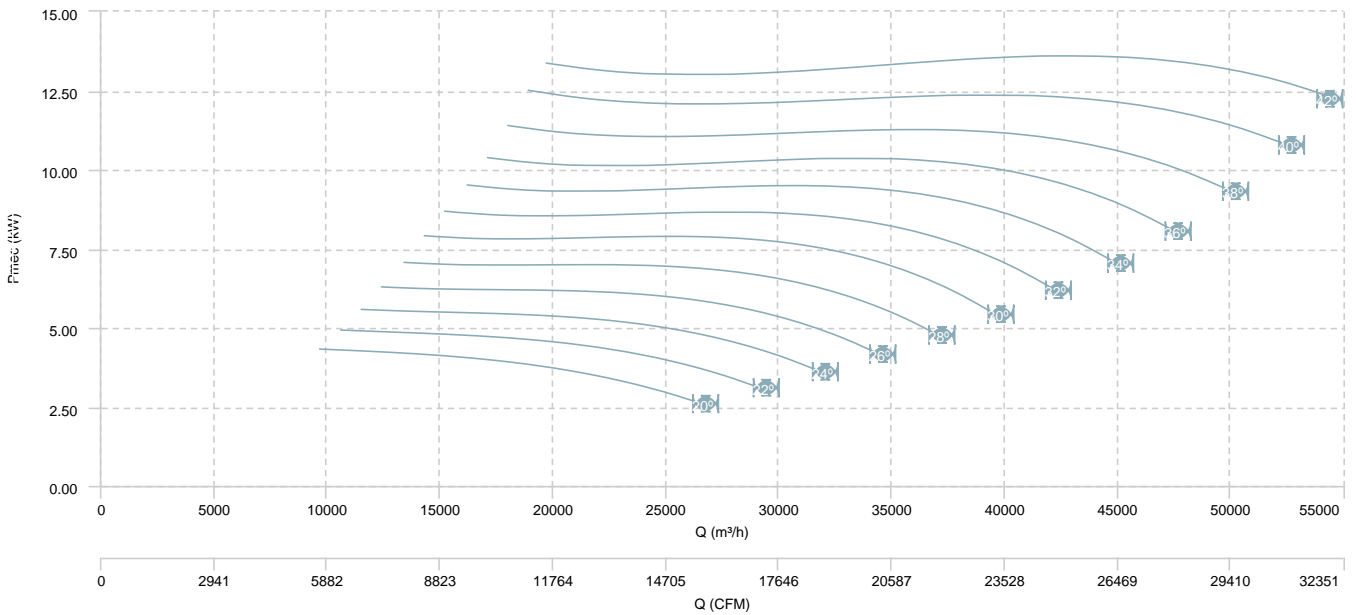

HCFX 90 T4/T8 (A3:8) F400

**AIR FLOW - PRESSURE (8 poles)**

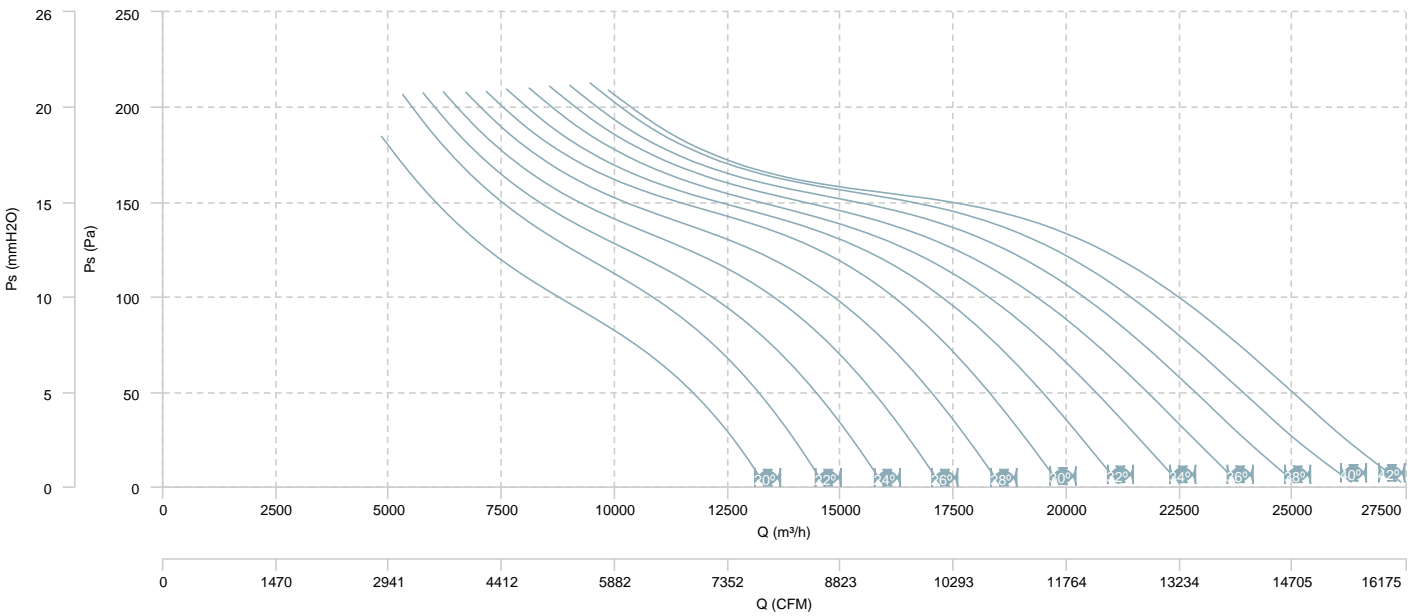

**AIR FLOW - MECHANICAL POWER (8 poles)**

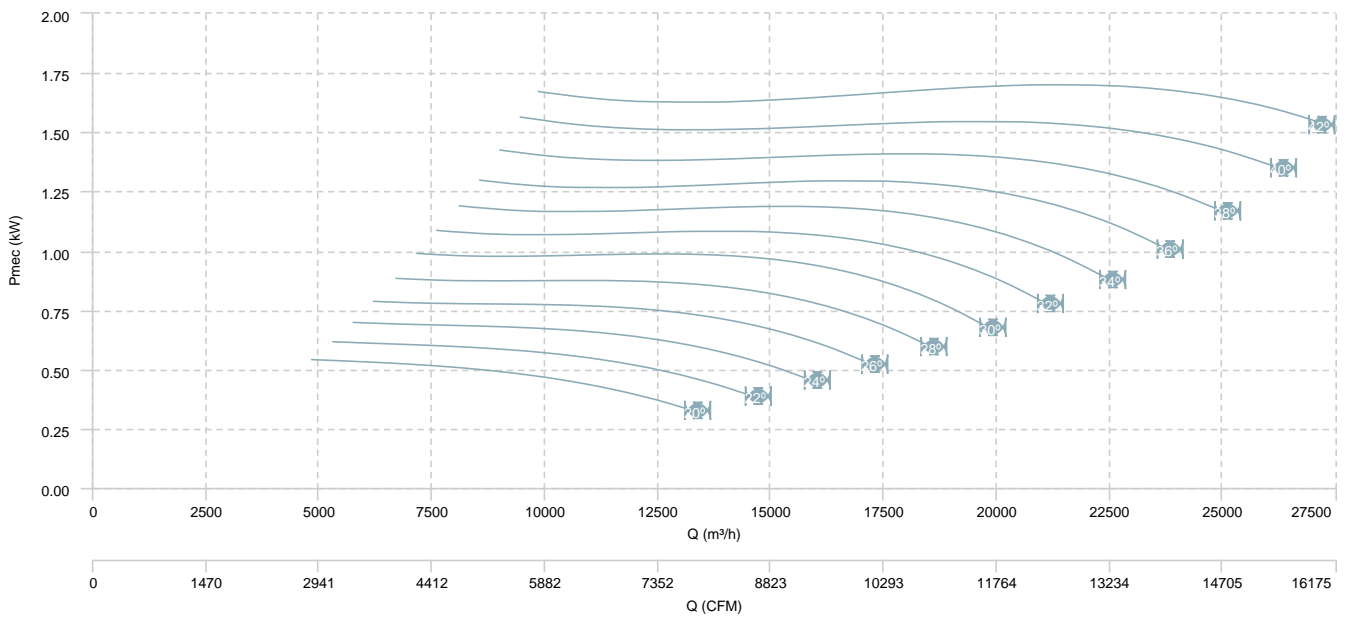



HCFX 100 T4 (A3:4) F400

**AIR FLOW - PRESSURE**

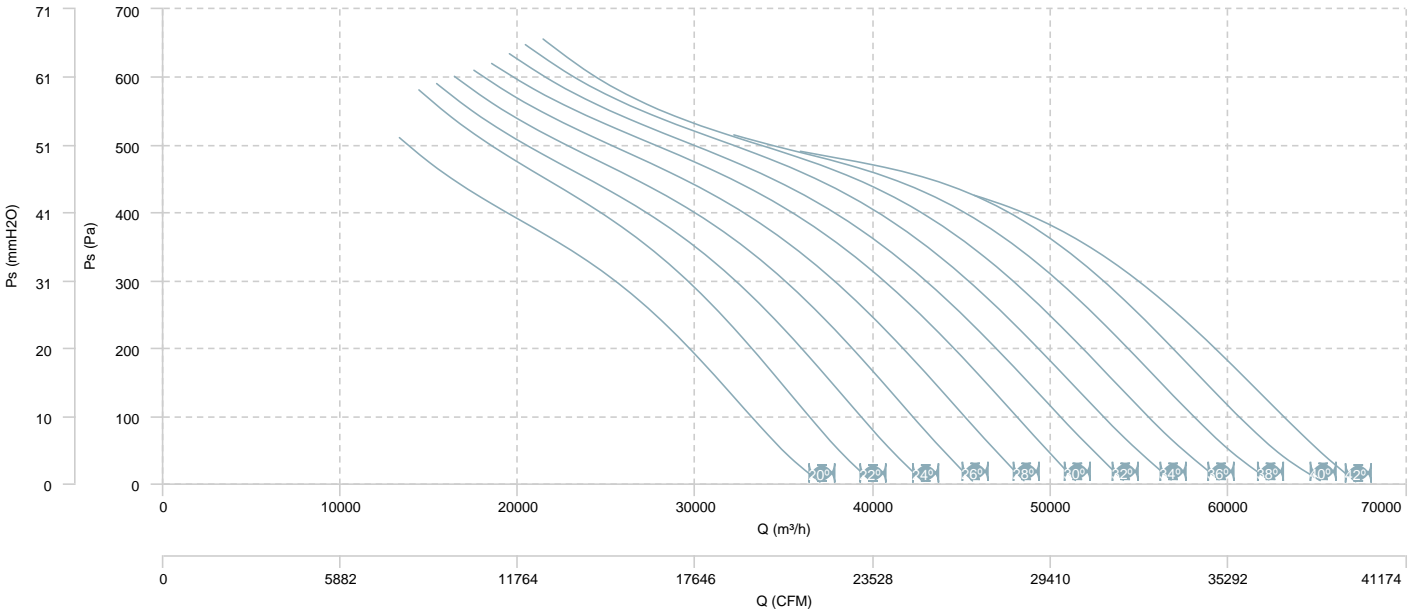

**AIR FLOW - MECHANICAL POWER**

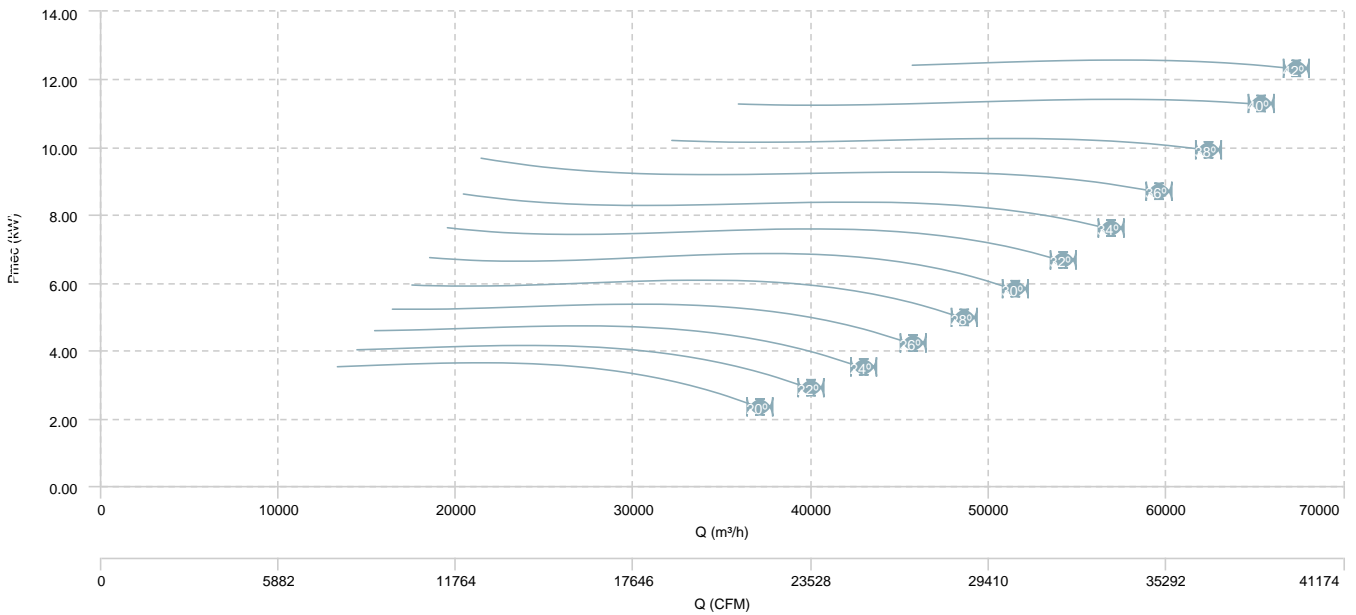

HCFX 100 T4 (A3:8) F400

**AIR FLOW - PRESSURE**

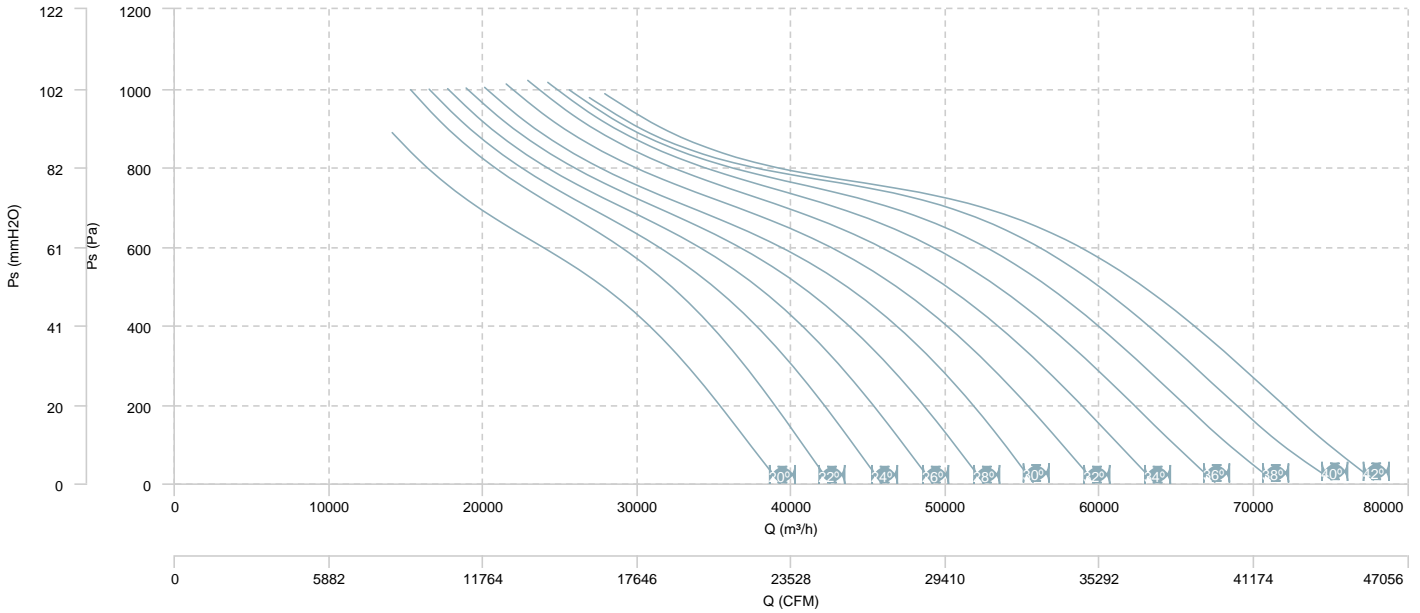

**AIR FLOW - MECHANICAL POWER**

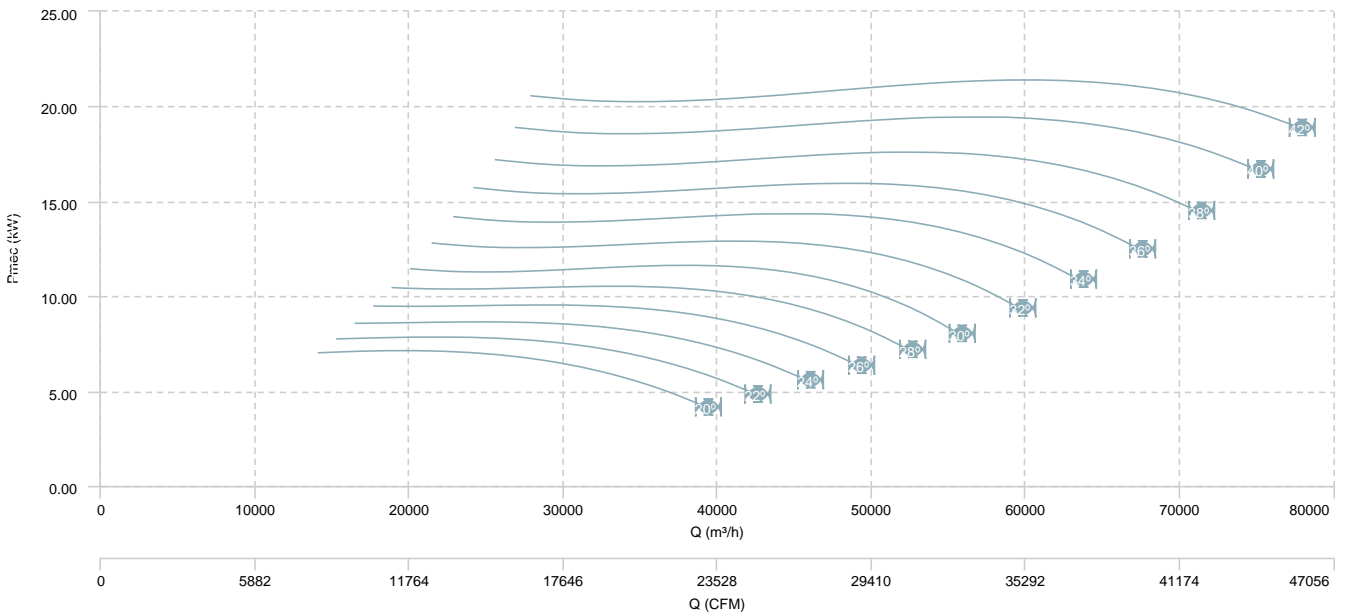

HCFX 100 T6 (A3:4) F400

**AIR FLOW - PRESSURE**

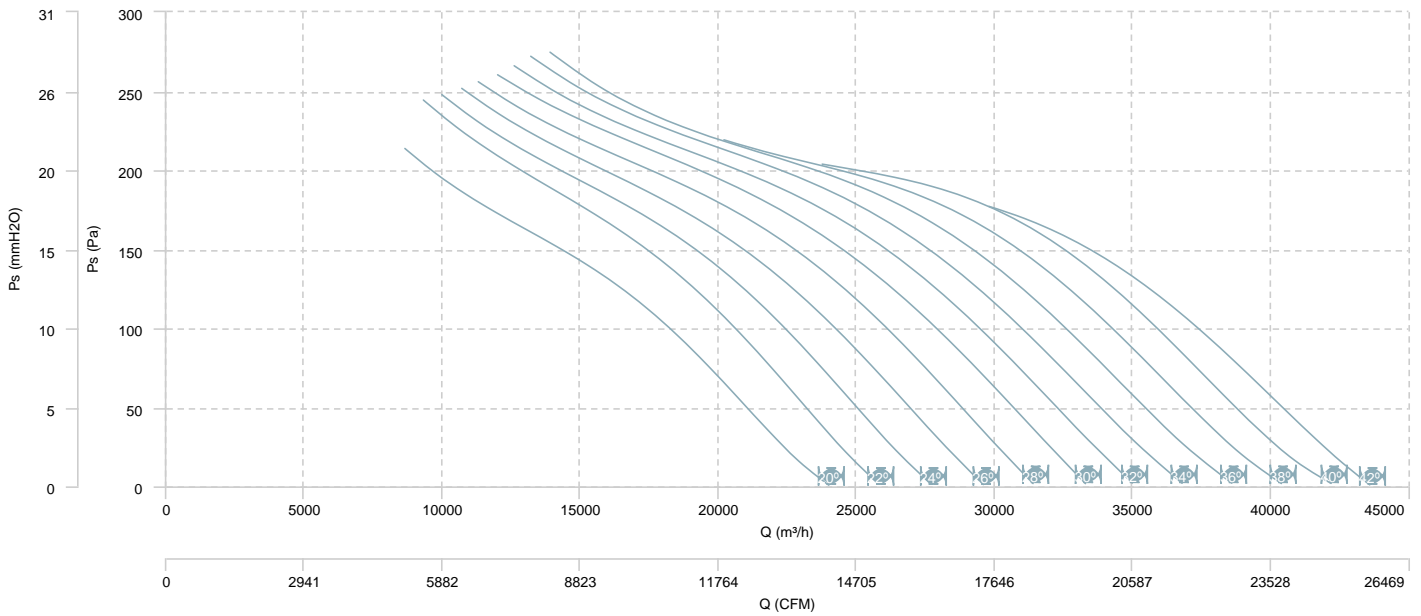

**AIR FLOW - MECHANICAL POWER**

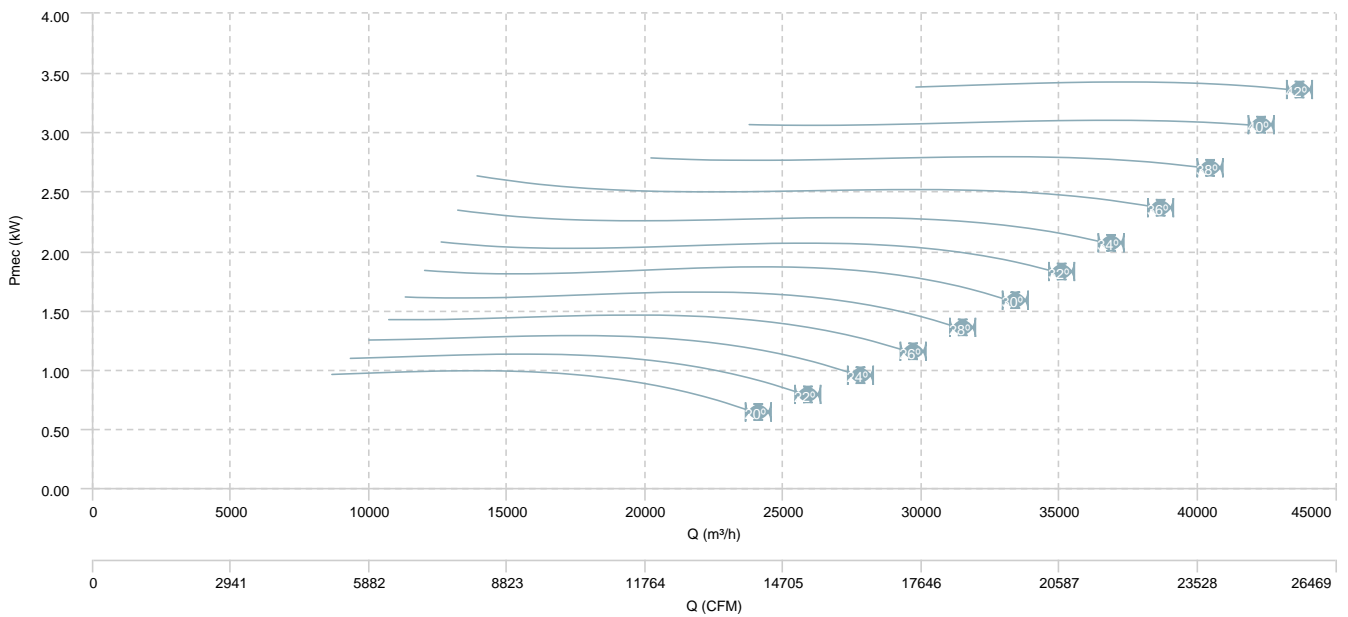

HCFX 100 T6 (A3:8) F400

**AIR FLOW - PRESSURE**

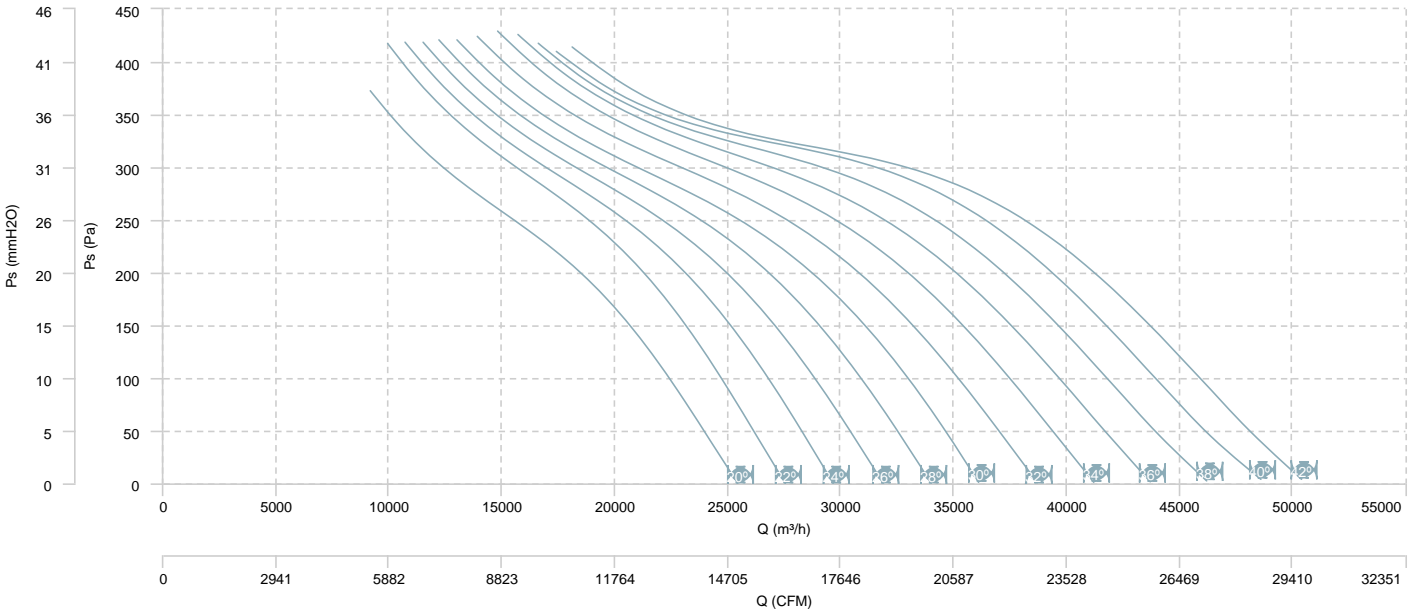

**AIR FLOW - MECHANICAL POWER**

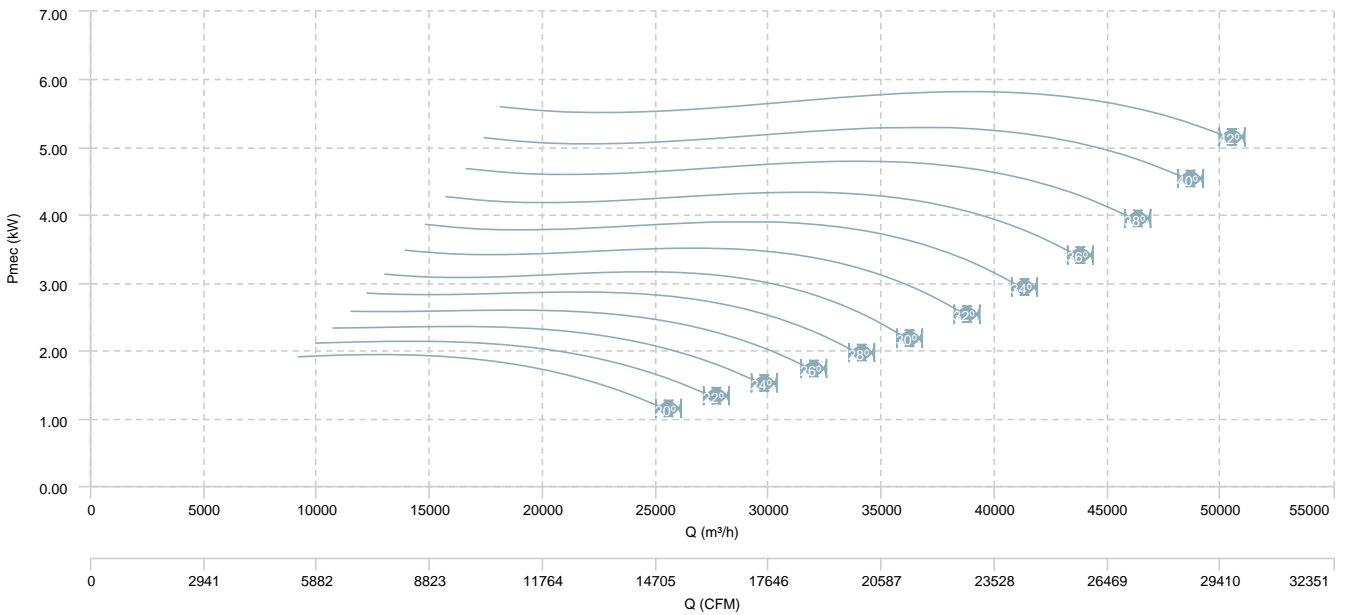

HCFX 100 T4/T8 (A3:4) F400

AIR FLOW - PRESSURE (4 poles)

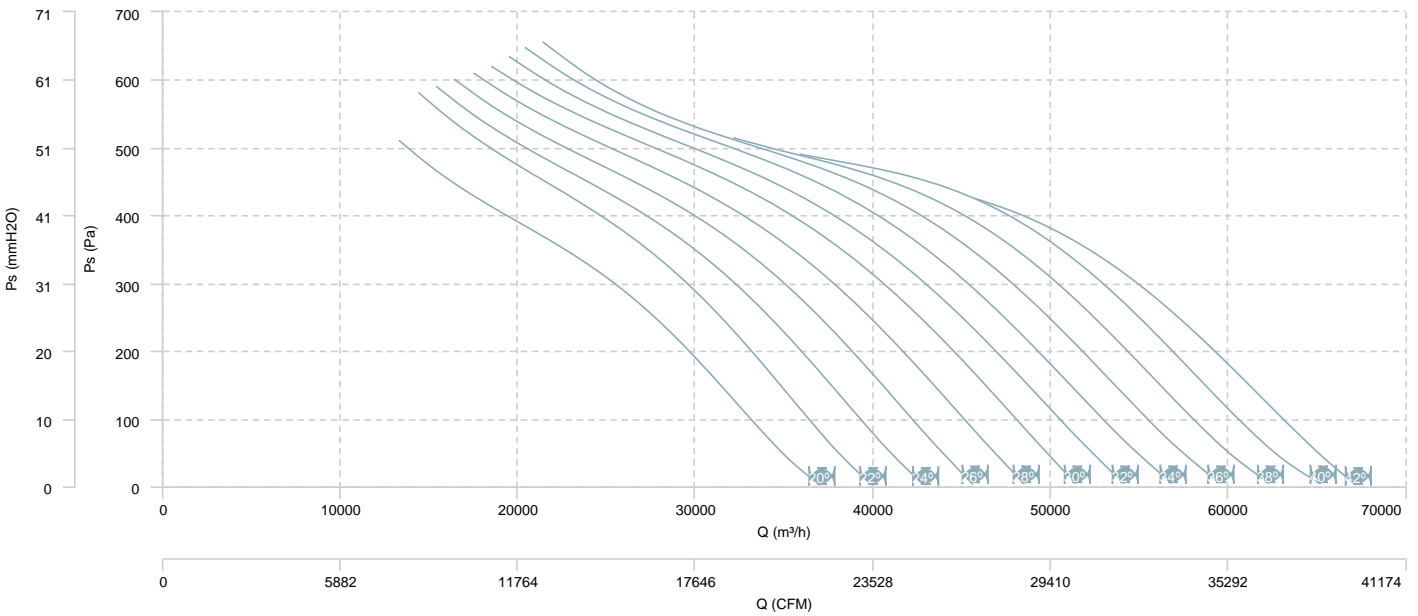

AIR FLOW - MECHANICAL POWER (4 poles)

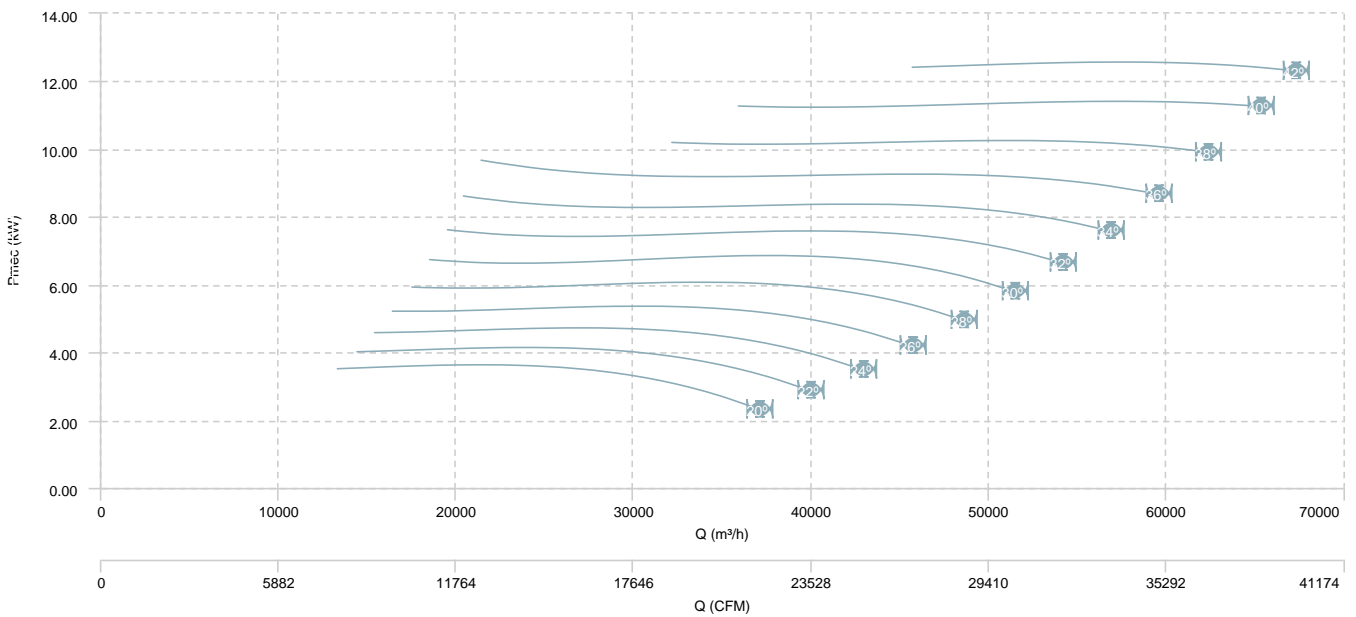

HCFX 100 T4/T8 (A3:4) F400

**AIR FLOW - PRESSURE (8 poles)**

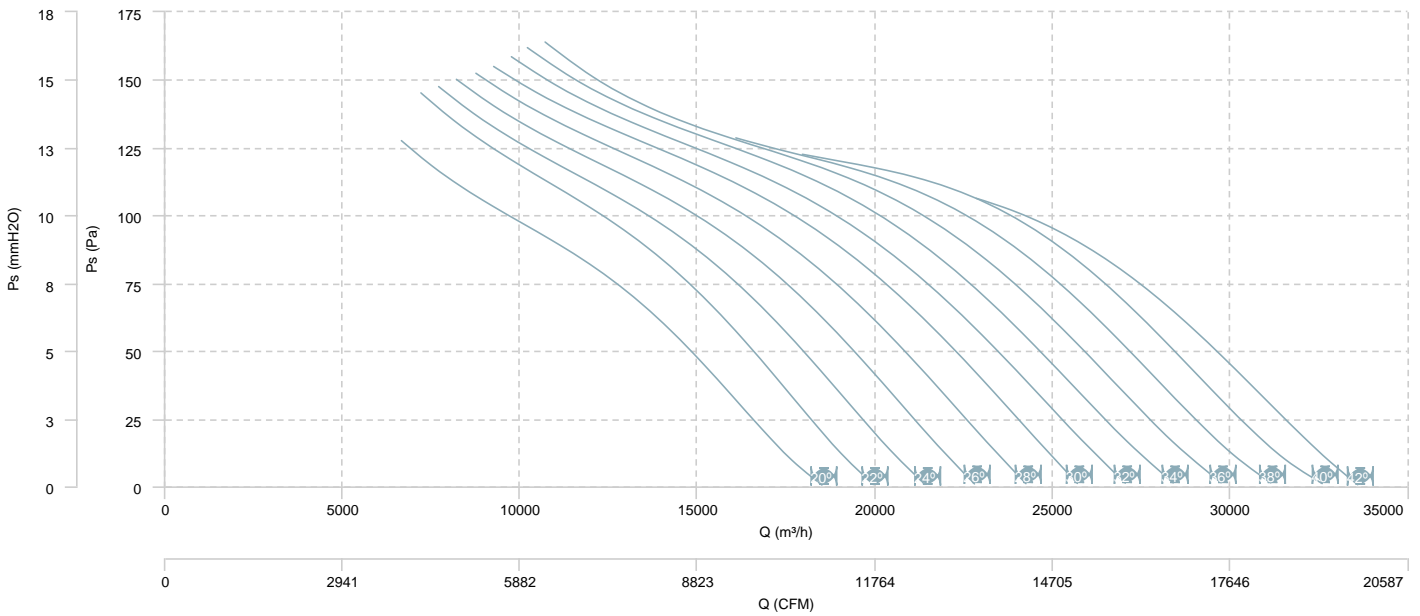

**AIR FLOW - MECHANICAL POWER (8 poles)**

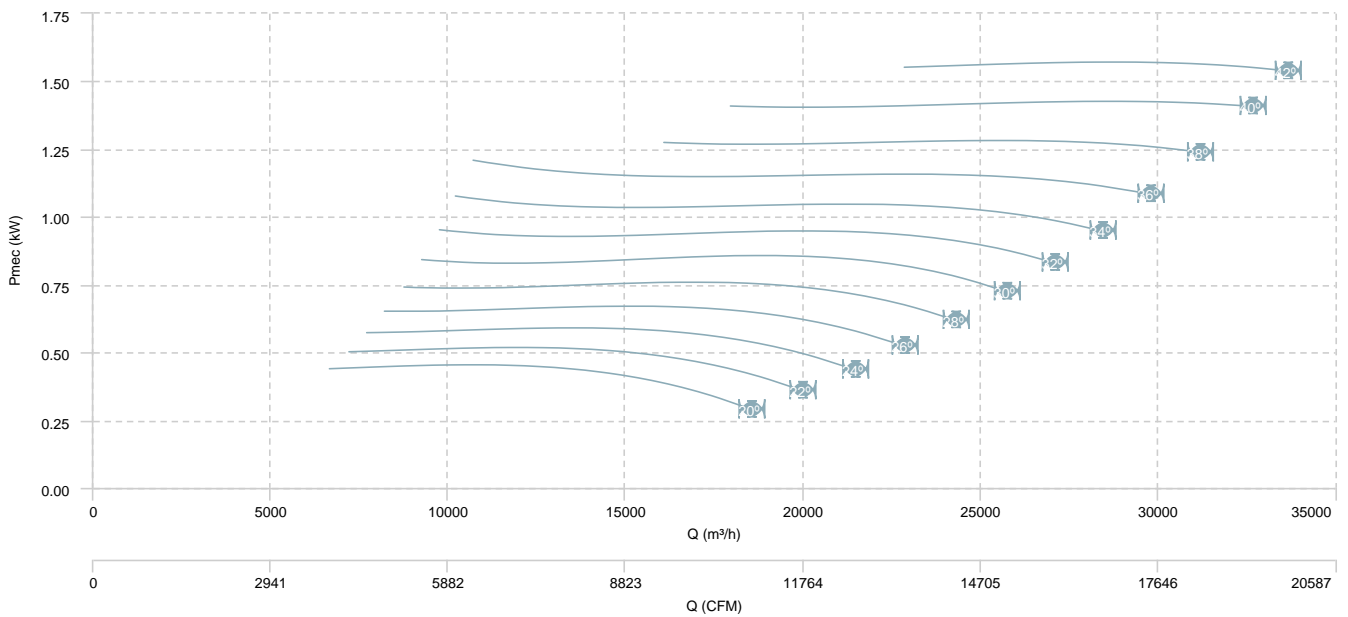

HCFX 100 T4/T8 (A3:8) F400

**AIR FLOW - PRESSURE (4 poles)**

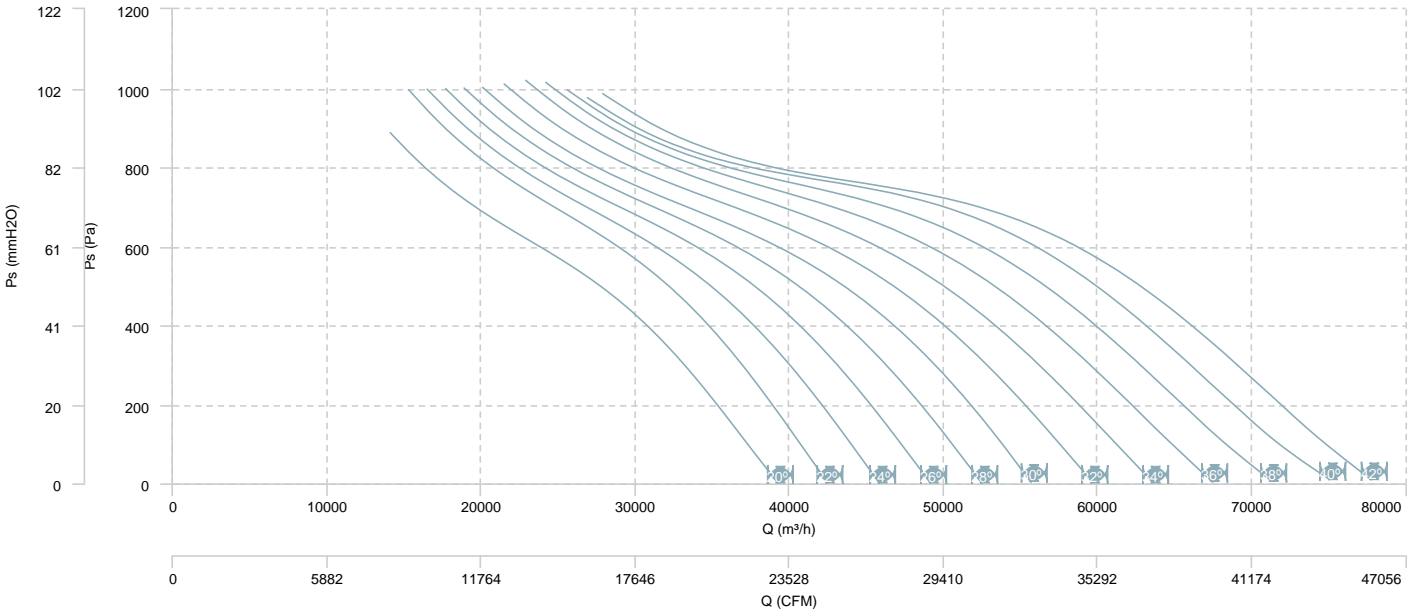

**AIR FLOW - MECHANICAL POWER (4 poles)**

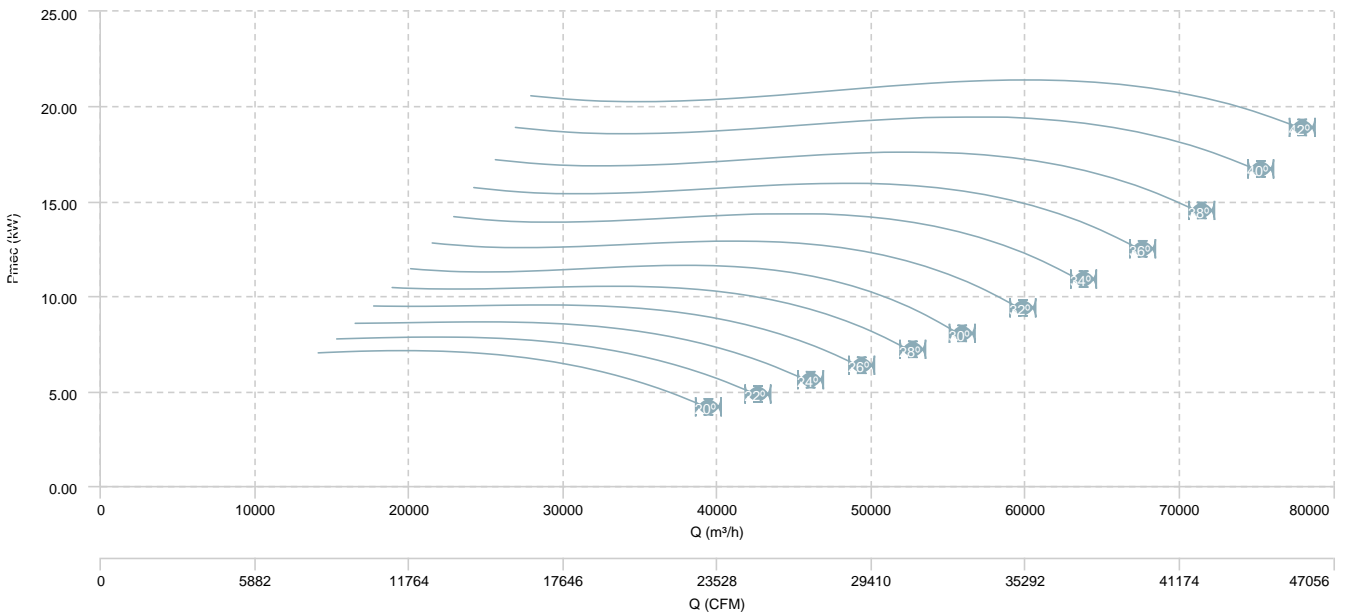

HCFX 100 T4/T8 (A3:8) F400

AIR FLOW - PRESSURE (8 poles)

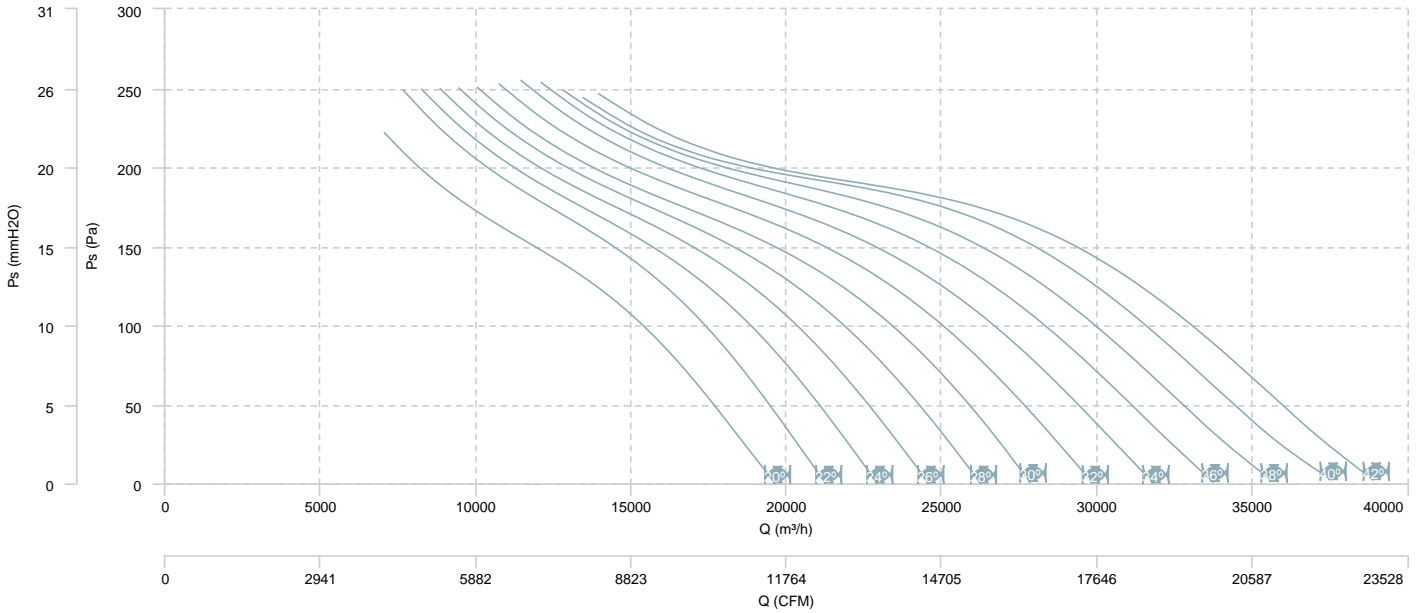

AIR FLOW - MECHANICAL POWER (8 poles)

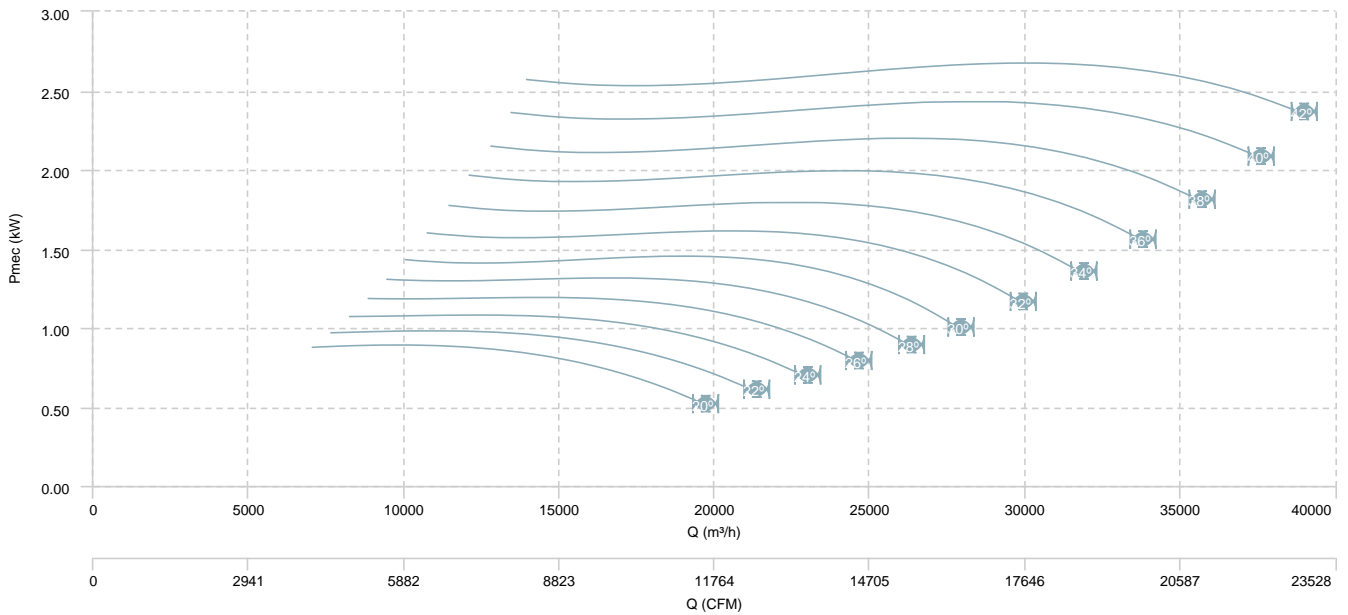



HCFX 112 T4 (A3:4) F400

**AIR FLOW - PRESSURE**

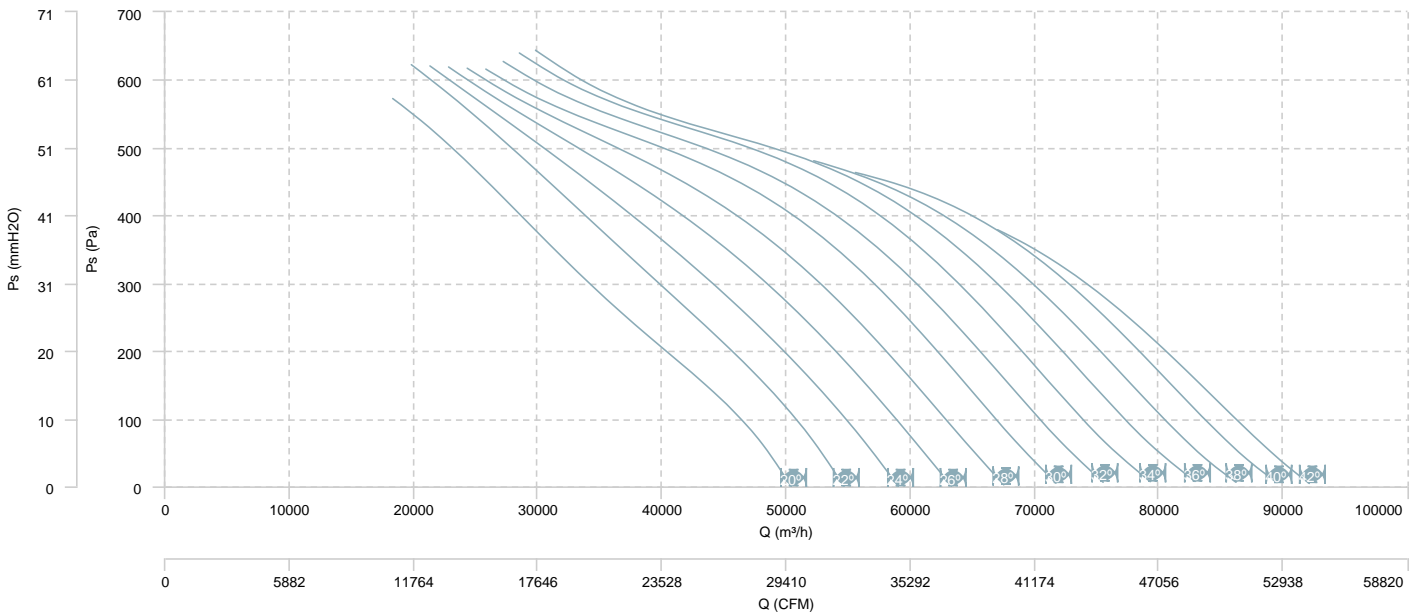

**AIR FLOW - MECHANICAL POWER**

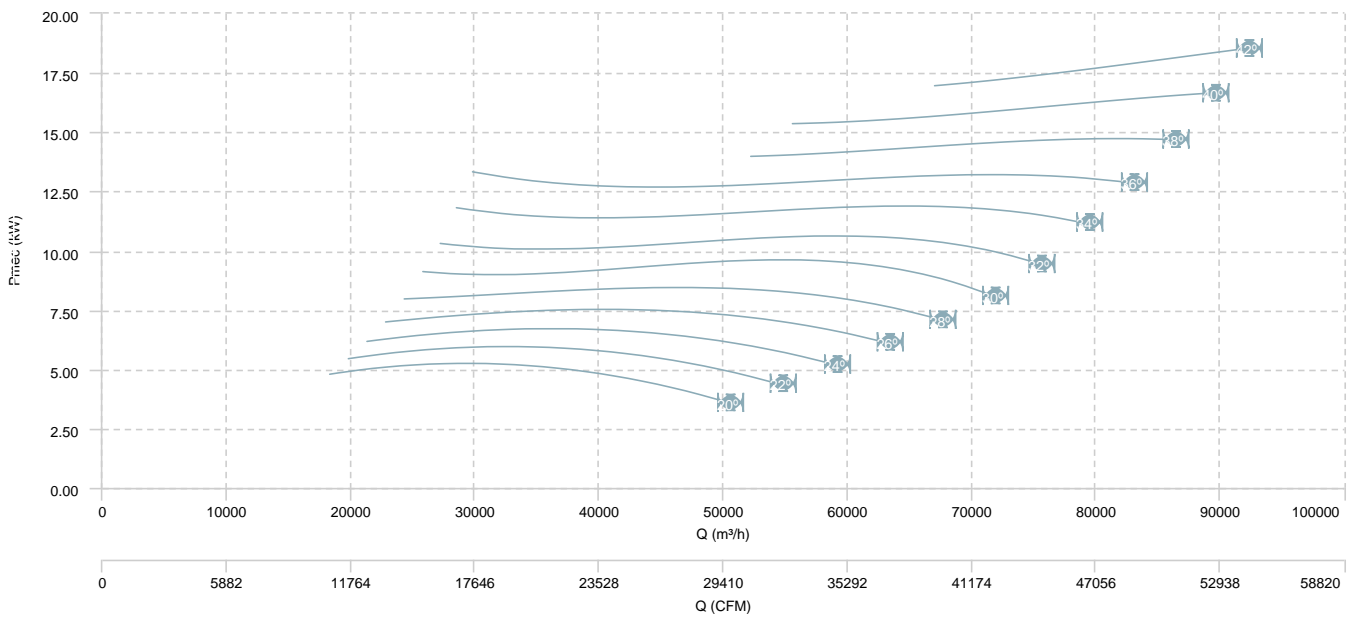

HCFX 112 T4 (A3:8) F400

**AIR FLOW - PRESSURE**

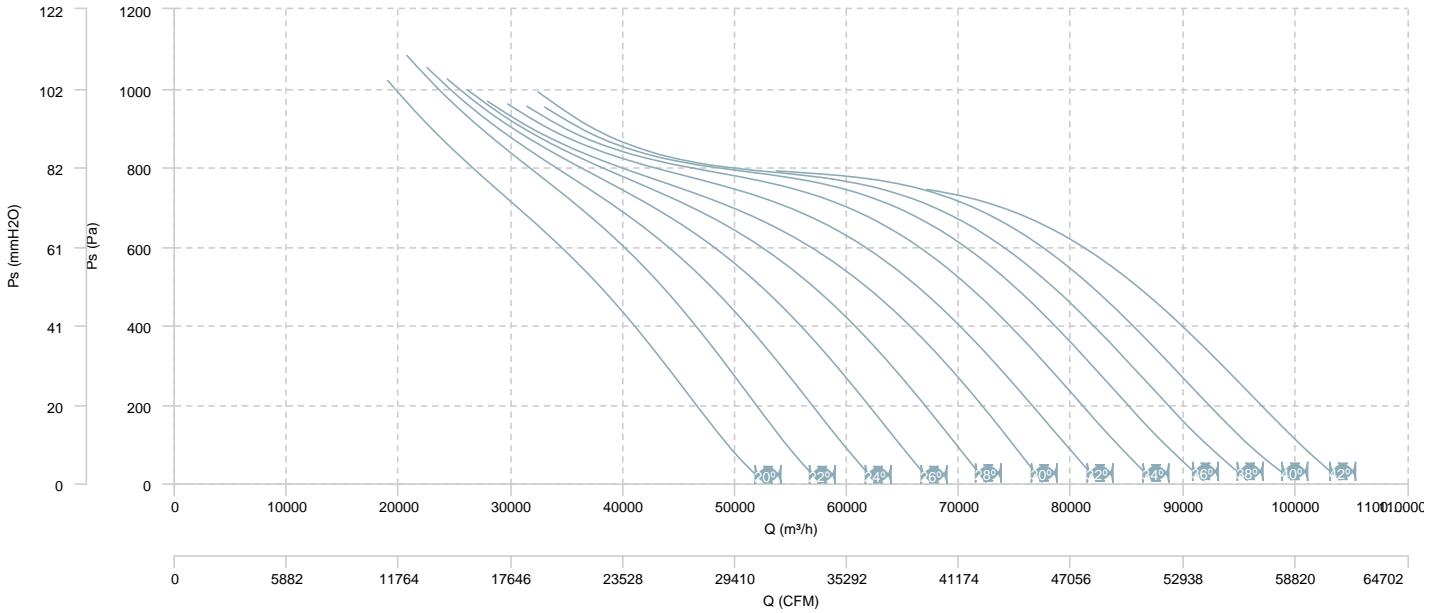

**AIR FLOW - MECHANICAL POWER**

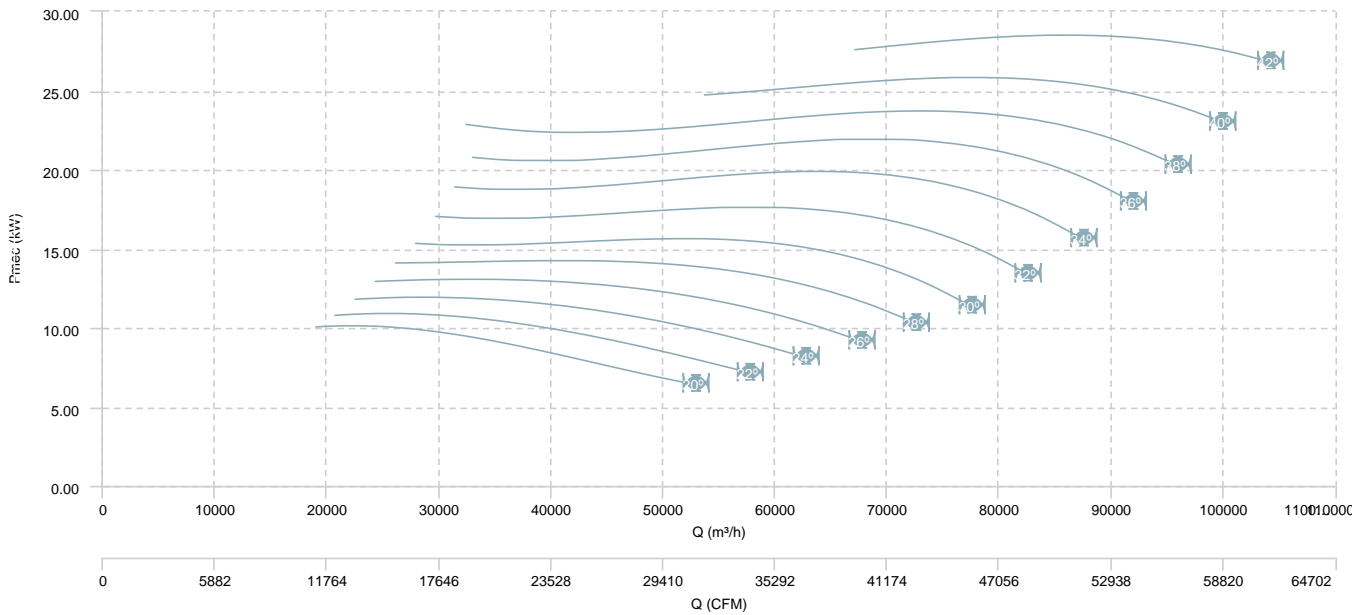

HCFX 112 T6 (A3:4) F400

**AIR FLOW - PRESSURE**

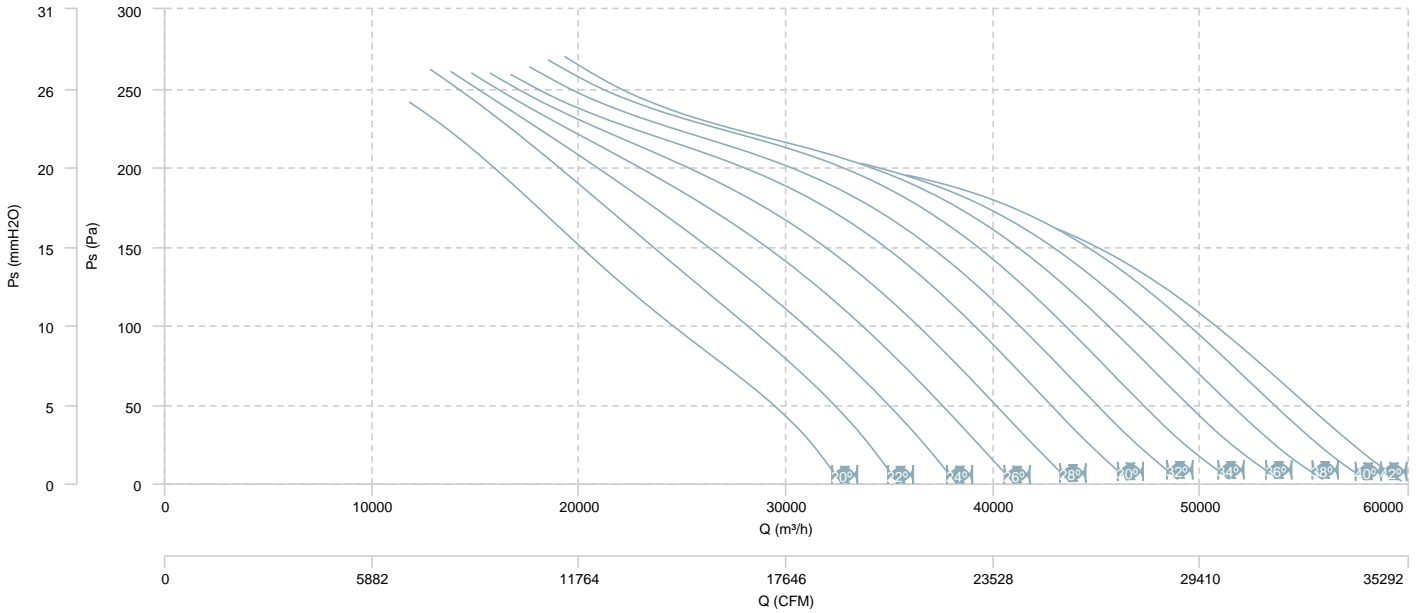

**AIR FLOW - MECHANICAL POWER**

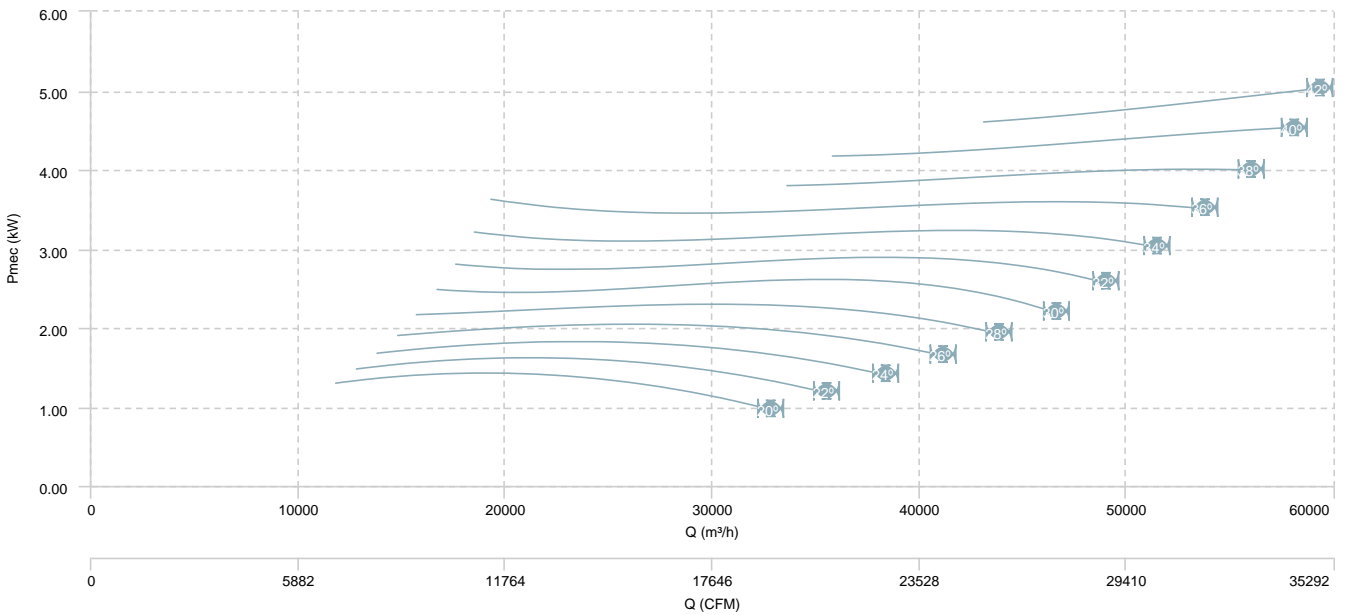

HCFX 112 T6 (A3:8) F400

**AIR FLOW - PRESSURE**

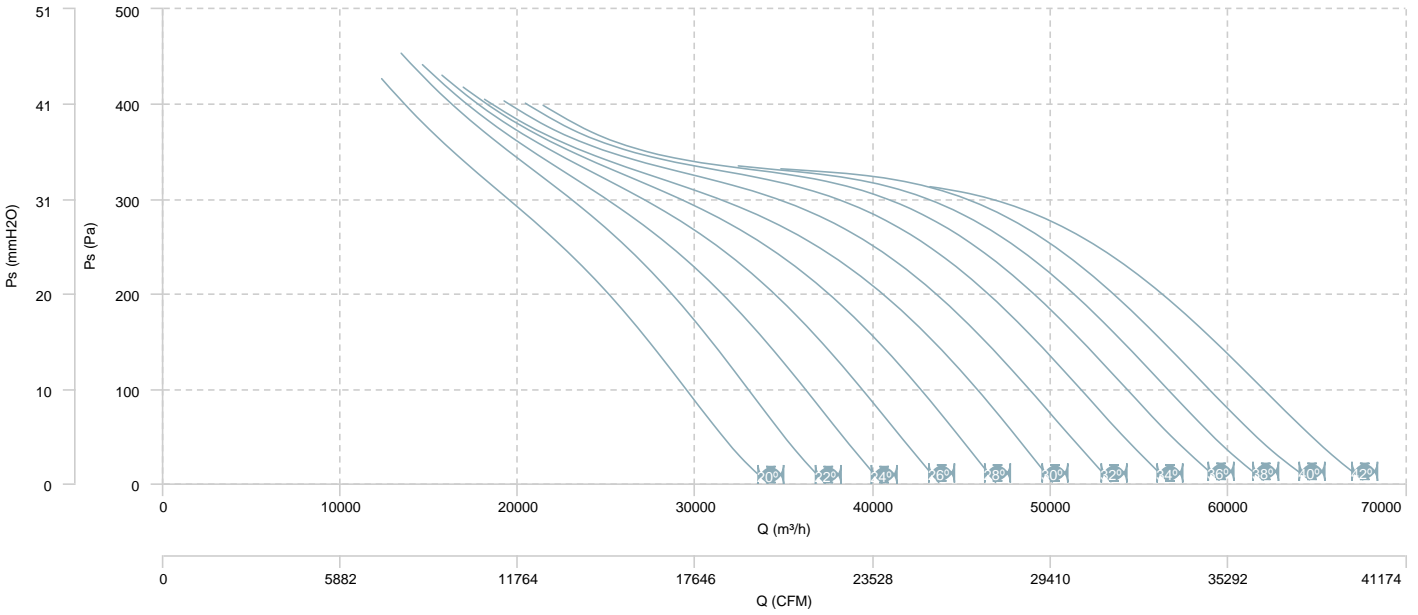

**AIR FLOW - MECHANICAL POWER**

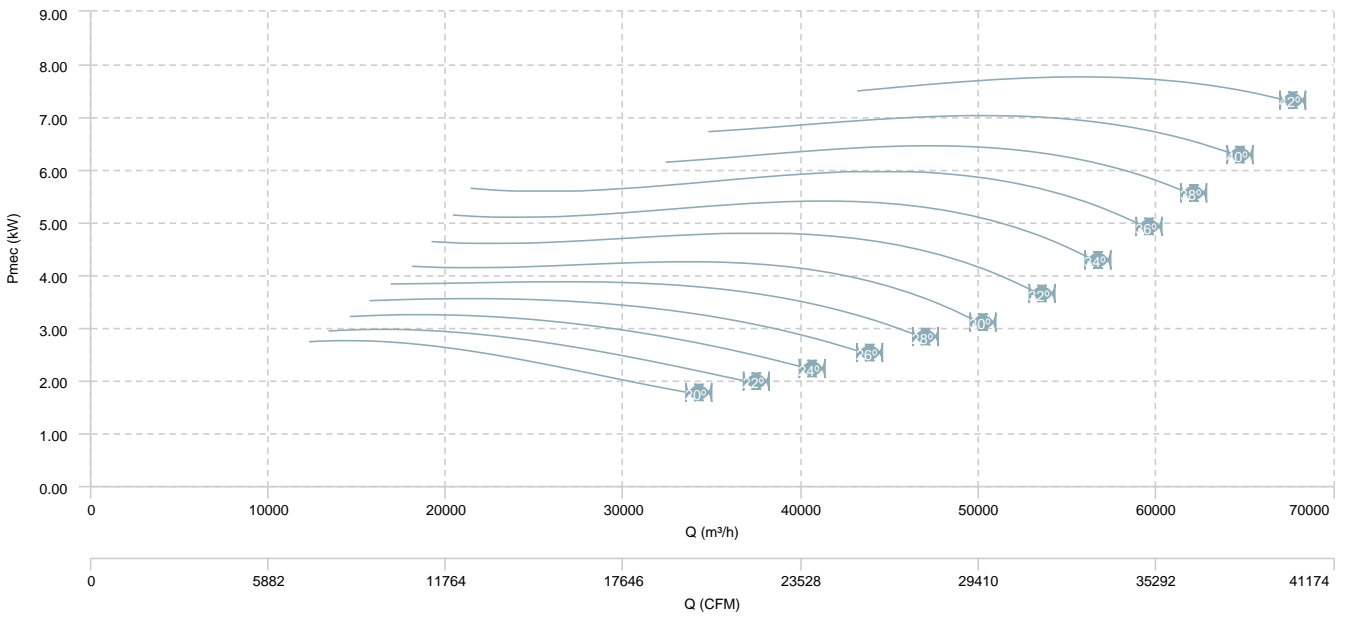

HCFX 112 T4/T8 (A3:4) F400

**AIR FLOW - PRESSURE (4 poles)**

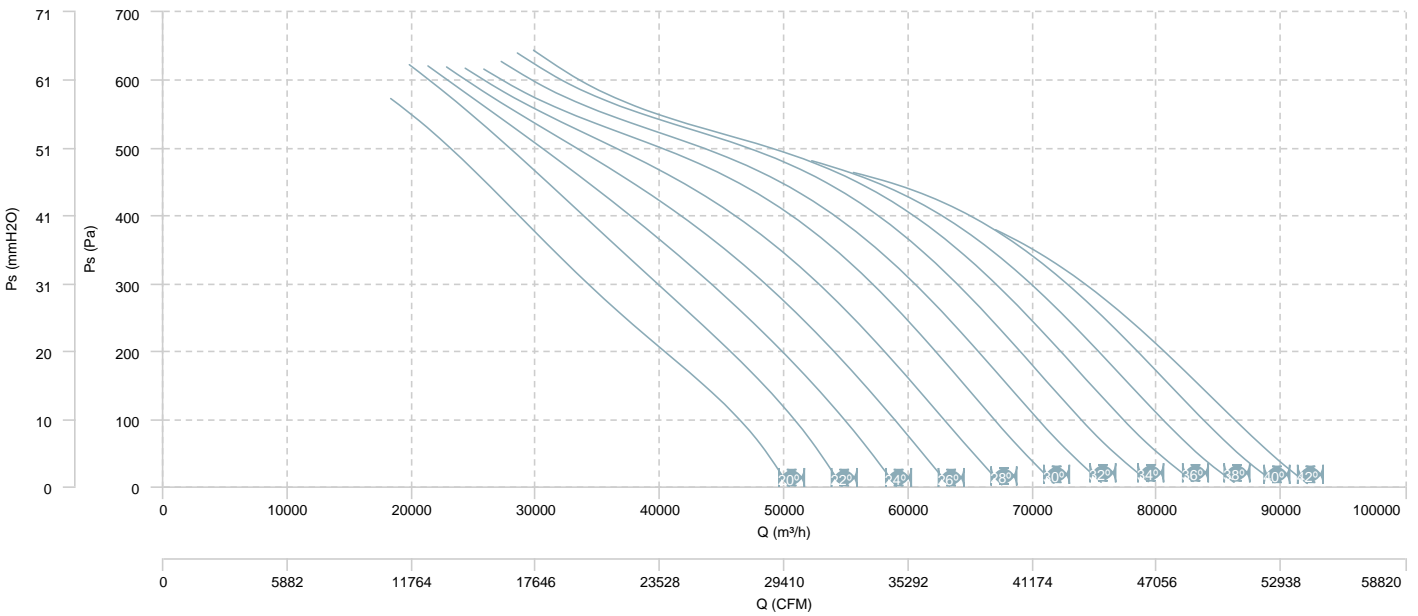

**AIR FLOW - MECHANICAL POWER (4 poles)**

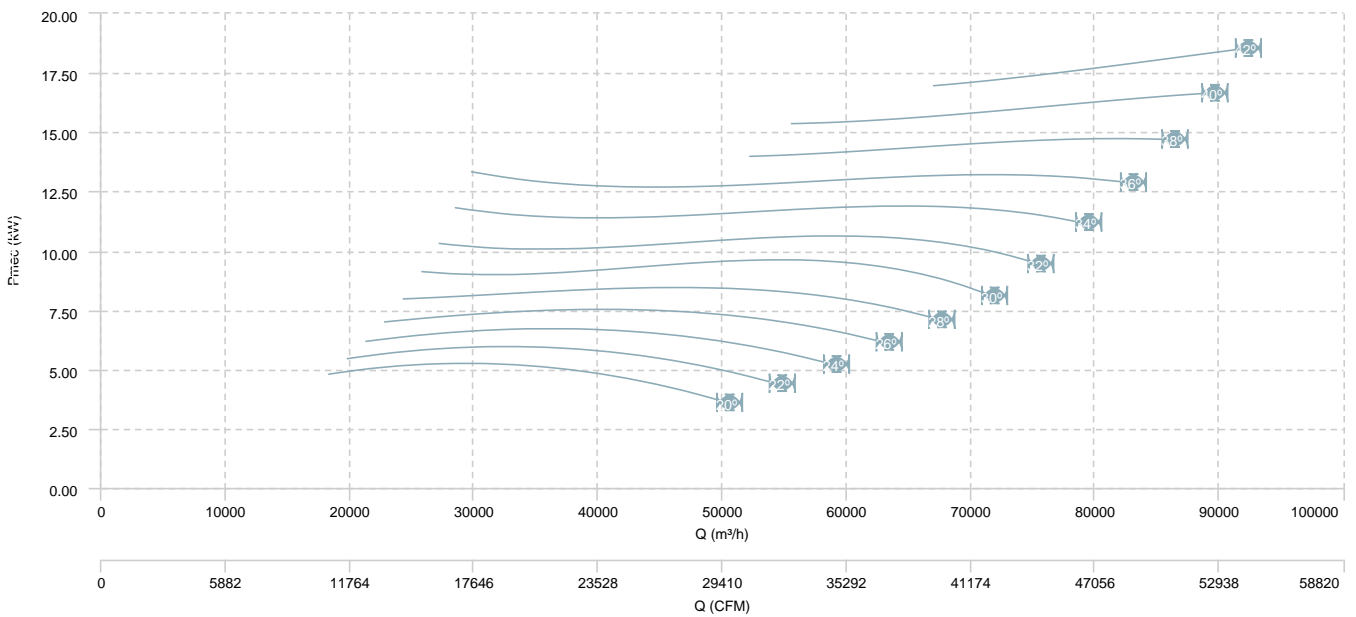

HCFX 112 T4/T8 (A3:4) F400

**AIR FLOW - PRESSURE (8 poles)**

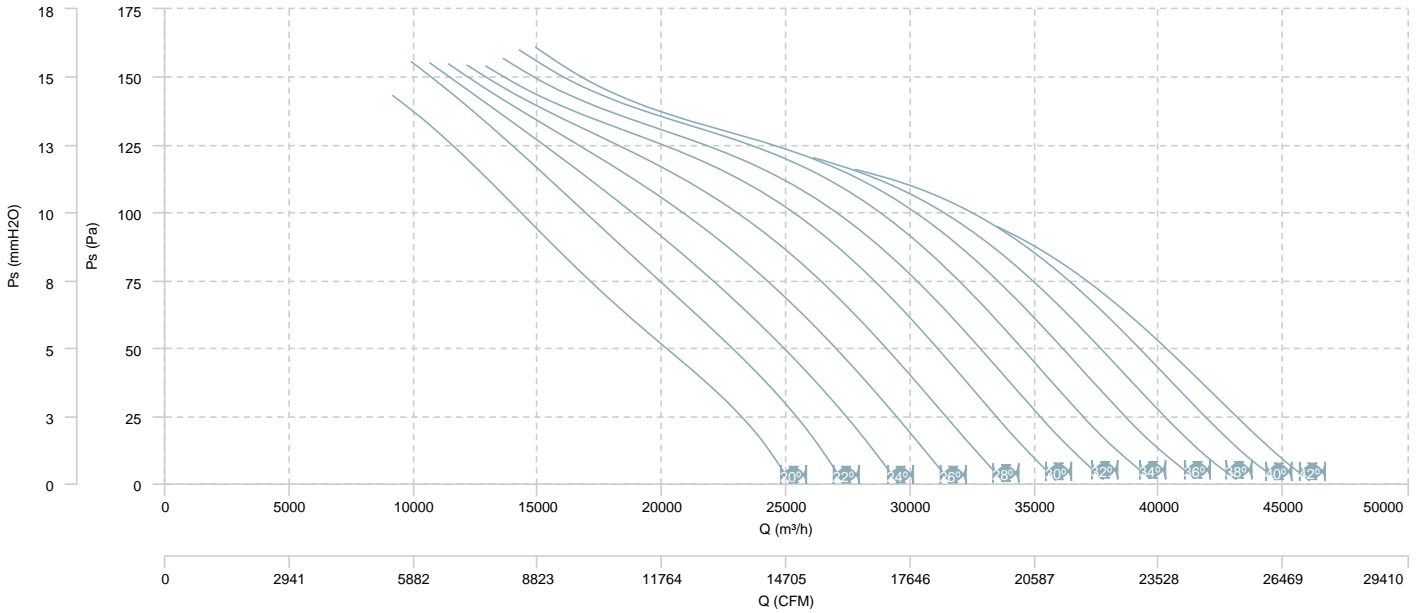

**AIR FLOW - MECHANICAL POWER (8 poles)**

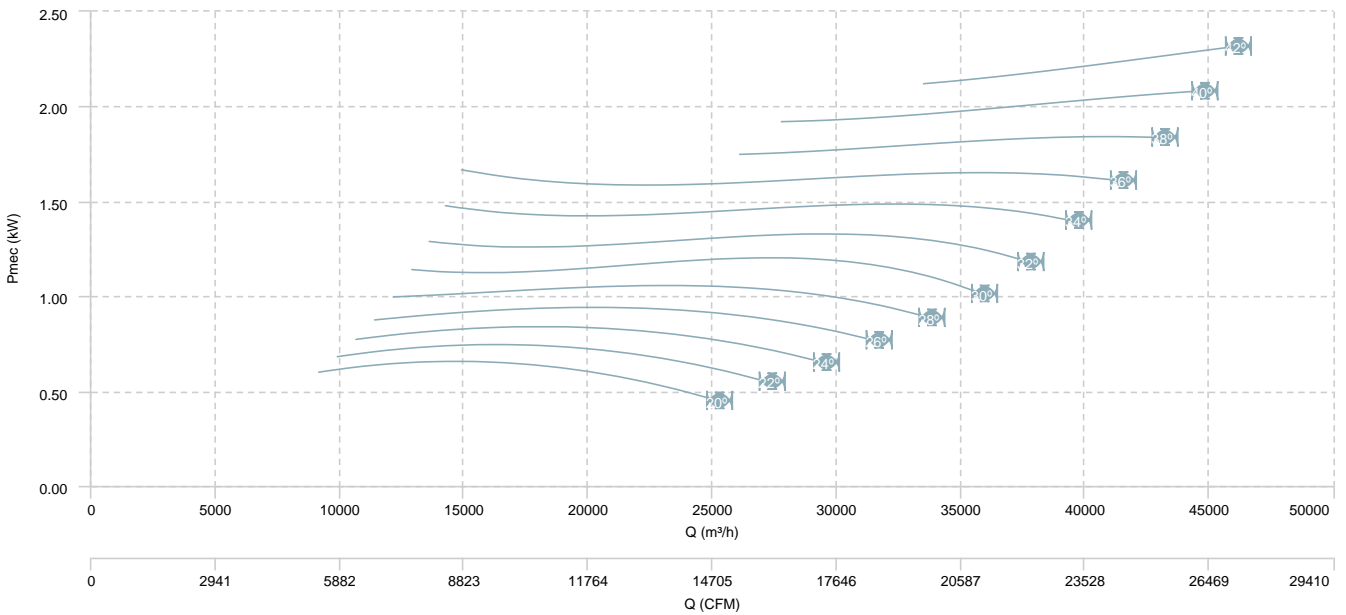

HCFX 112 T4/T8 (A3:8) F400

**AIR FLOW - PRESSURE (4 poles)**

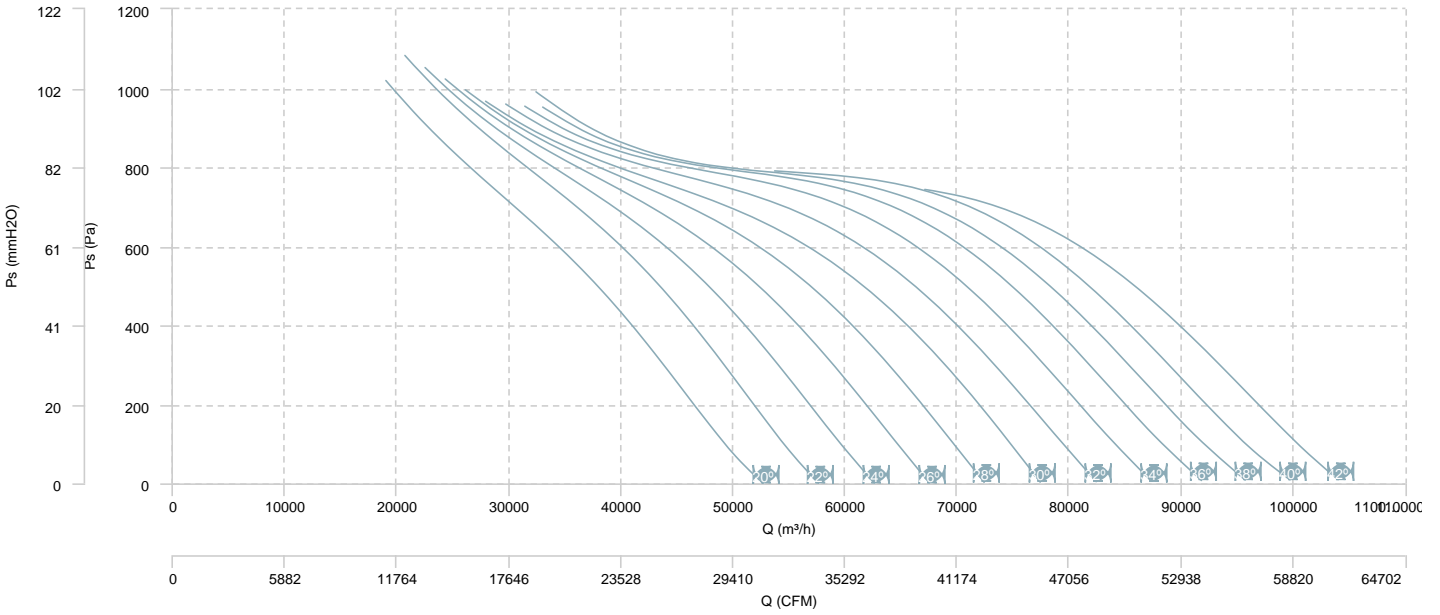

**AIR FLOW - MECHANICAL POWER (4 poles)**

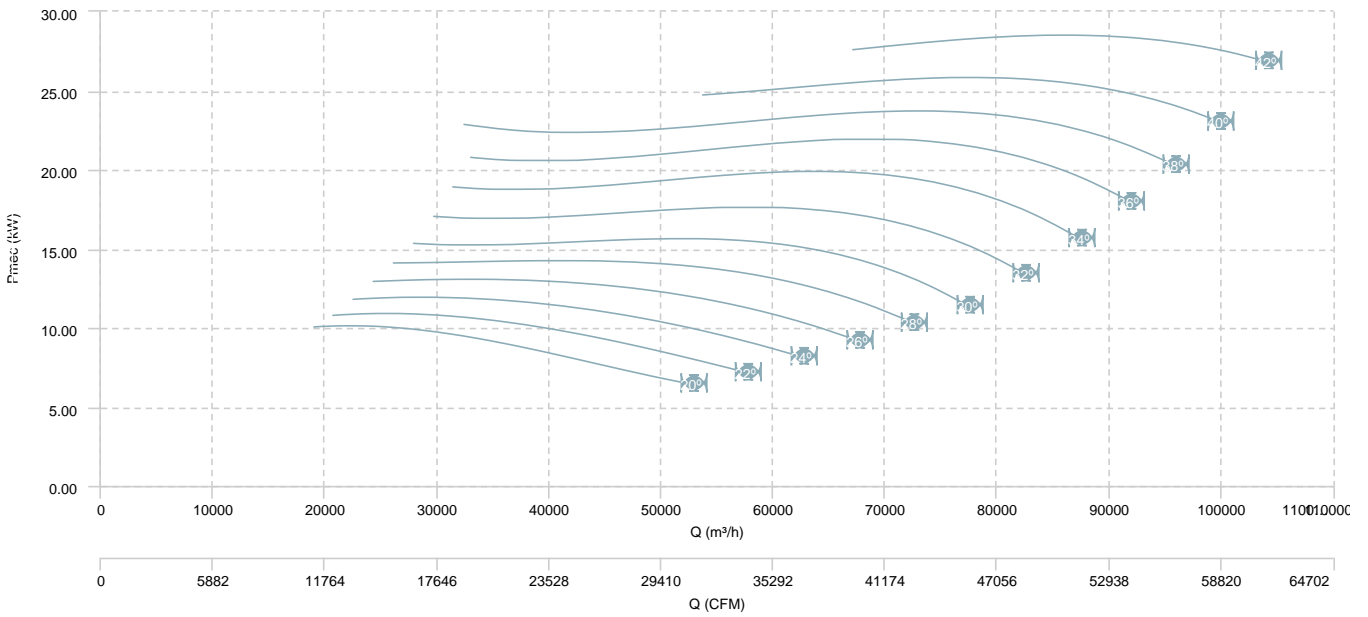

HCFX 112 T4/T8 (A3:8) F400

**AIR FLOW - PRESSURE (8 poles)**

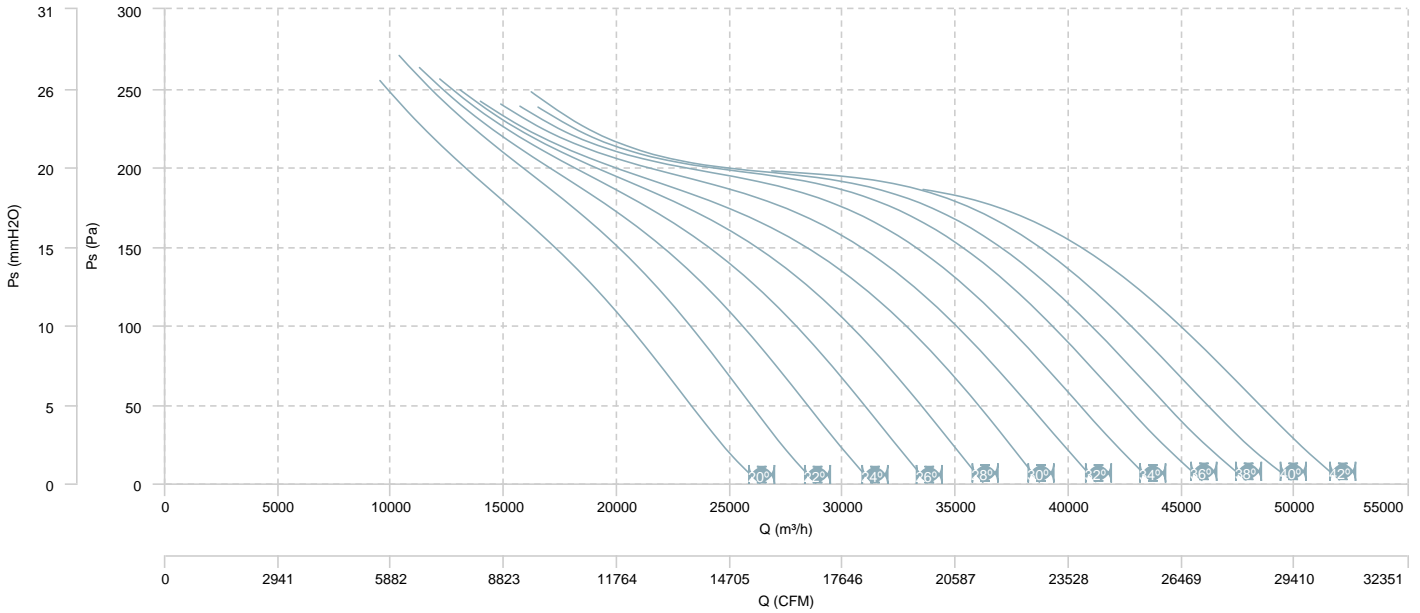

**AIR FLOW - MECHANICAL POWER (8 poles)**

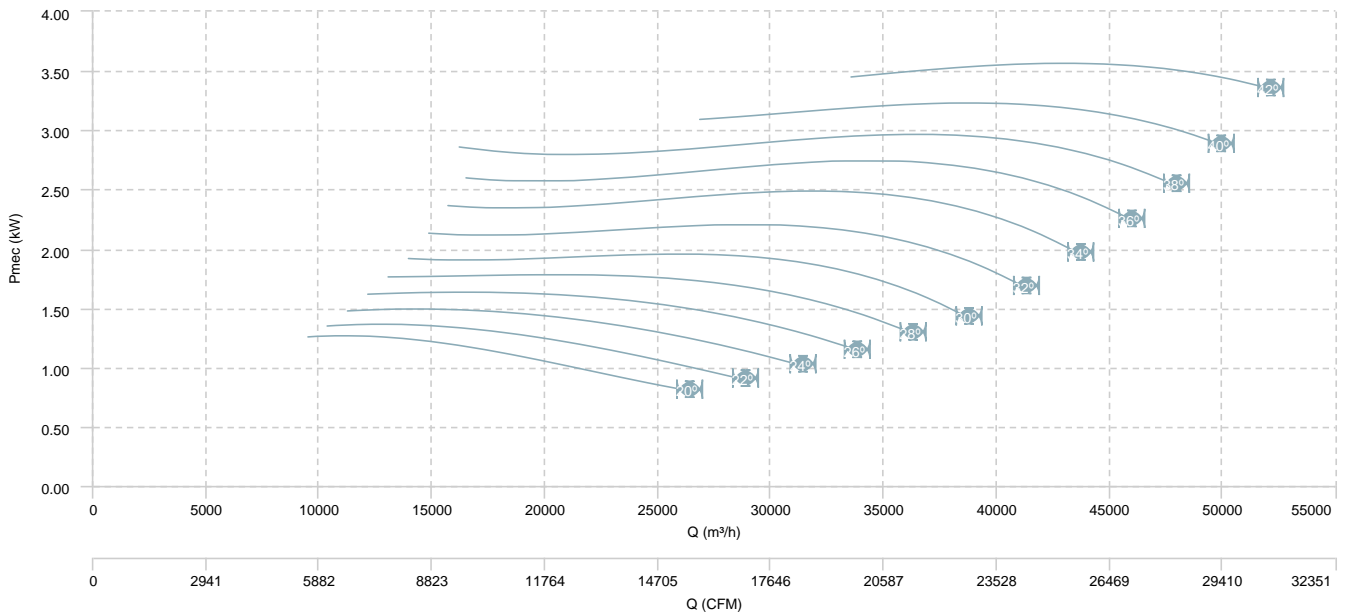



HCFX 125 T4 (A3:4) F400

**AIR FLOW - PRESSURE**

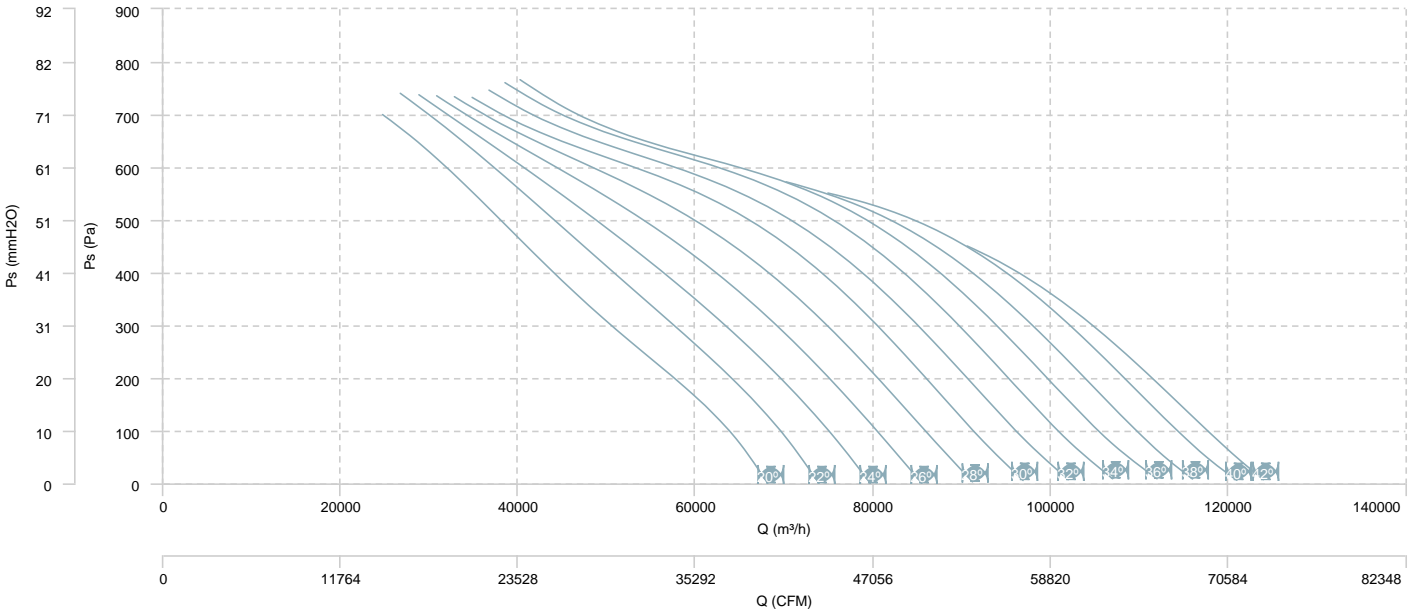

**AIR FLOW - MECHANICAL POWER**

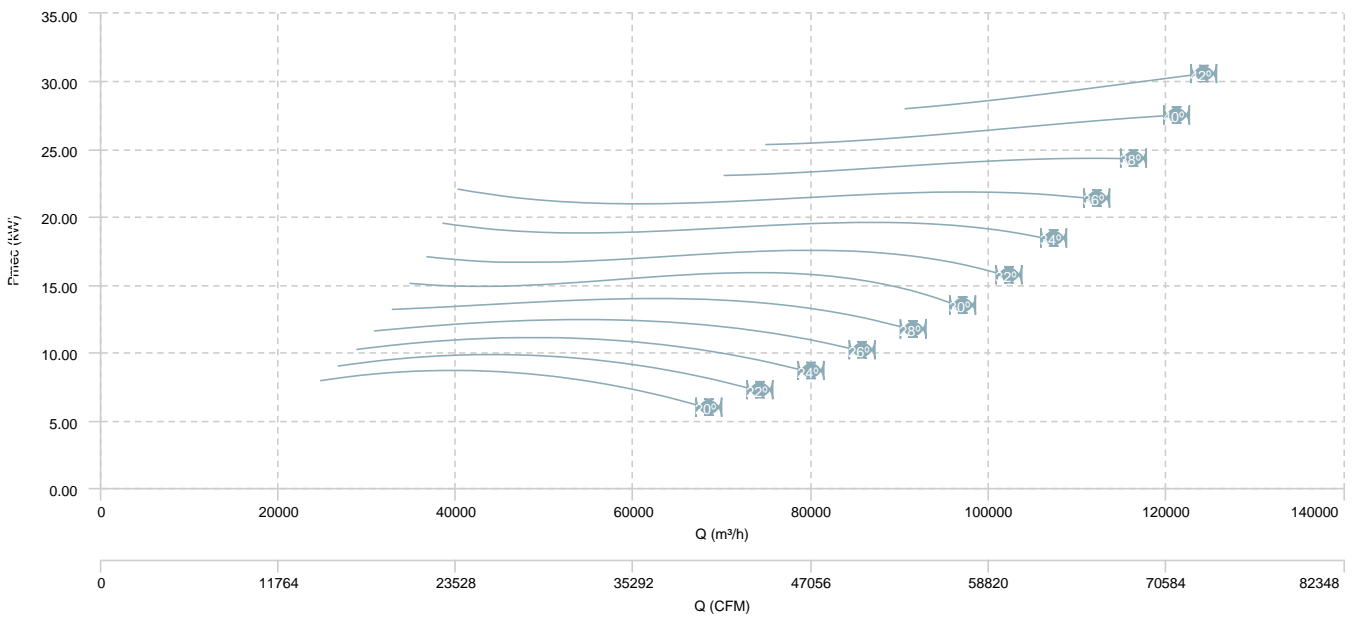

HCFX 125 T4 (A3:8) F400

**AIR FLOW - PRESSURE**

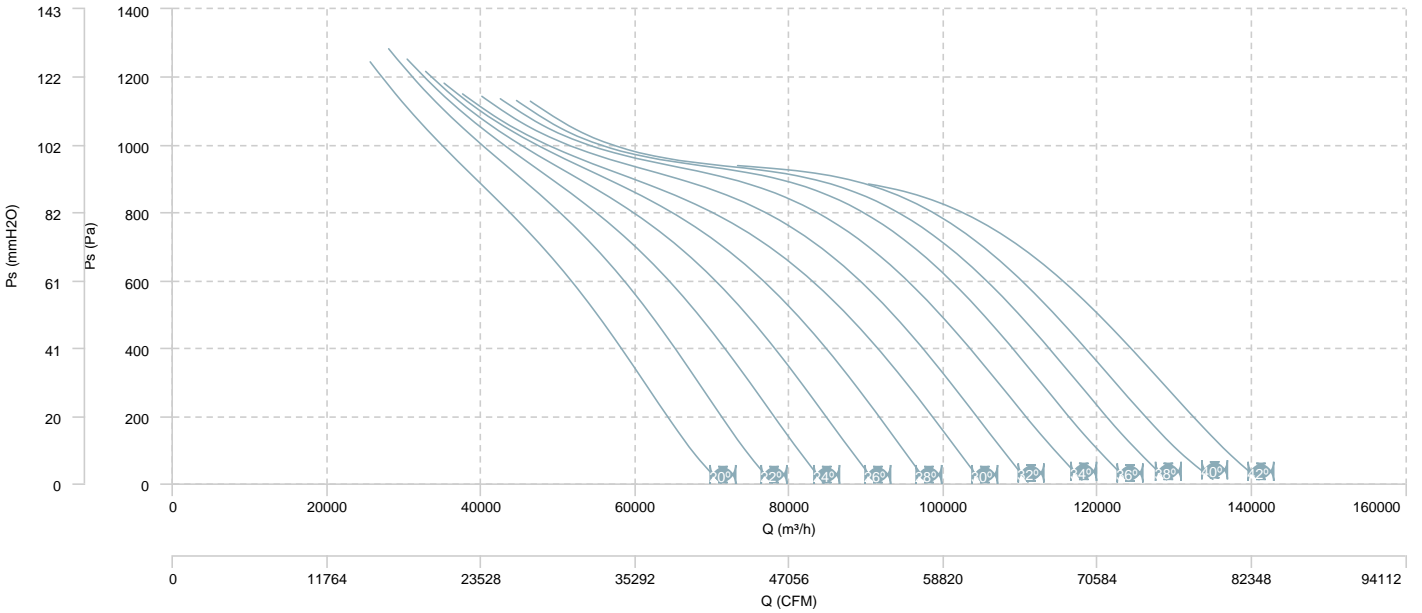

**AIR FLOW - MECHANICAL POWER**

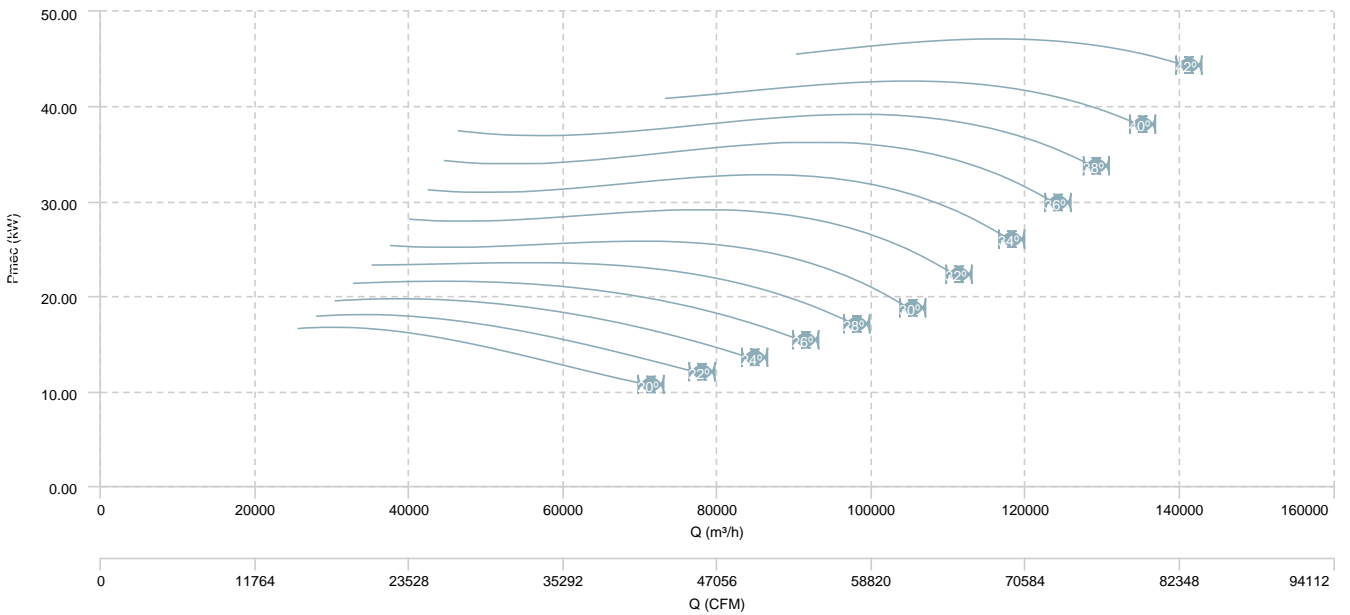

HCFX 125 T6 (A3:4) F400

**AIR FLOW - PRESSURE**

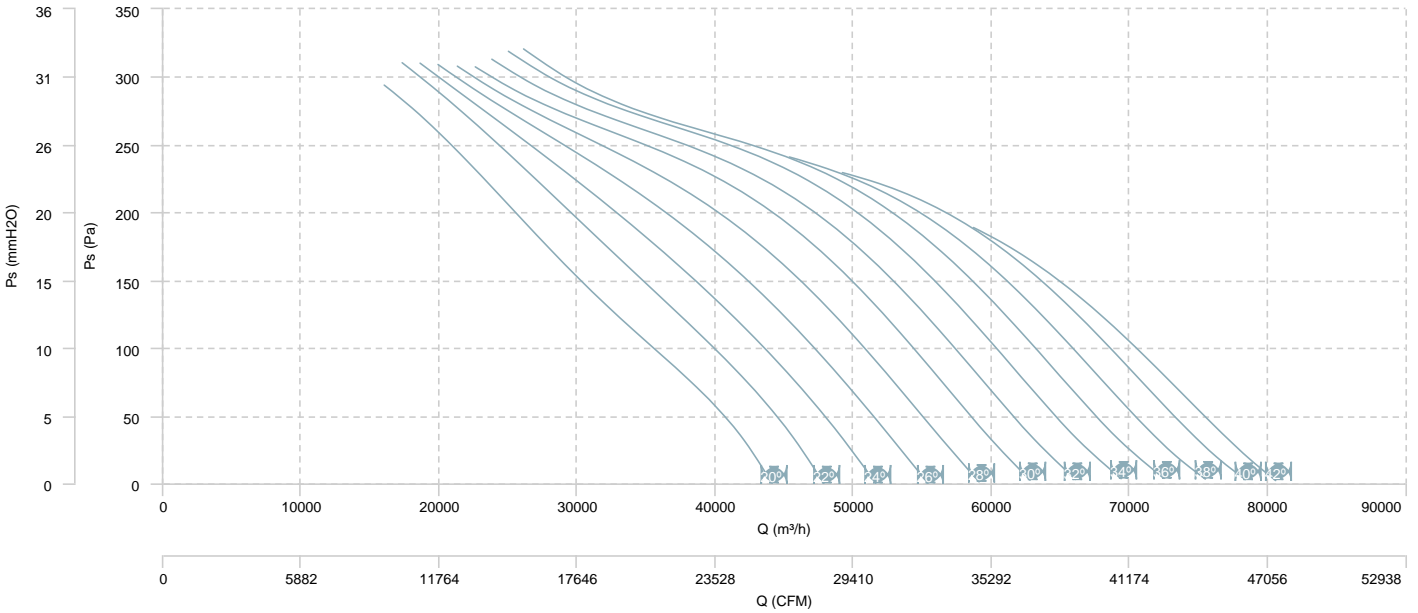

**AIR FLOW - MECHANICAL POWER**

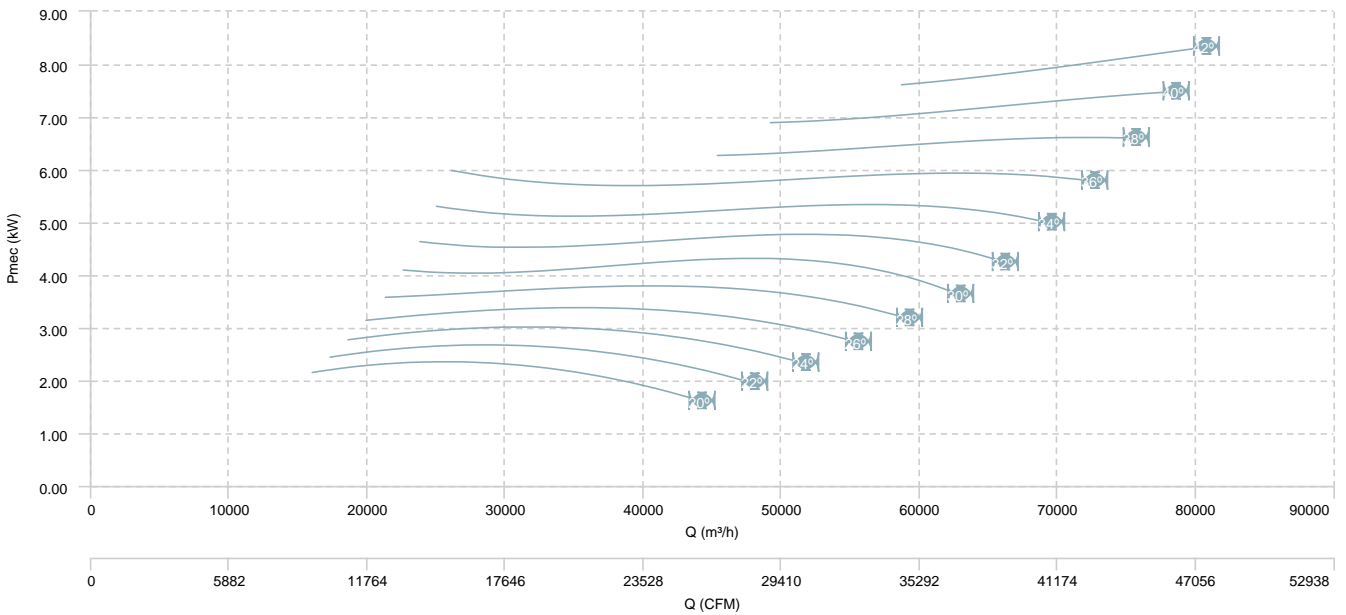

HCFX 125 T6 (A3:8) F400

**AIR FLOW - PRESSURE**

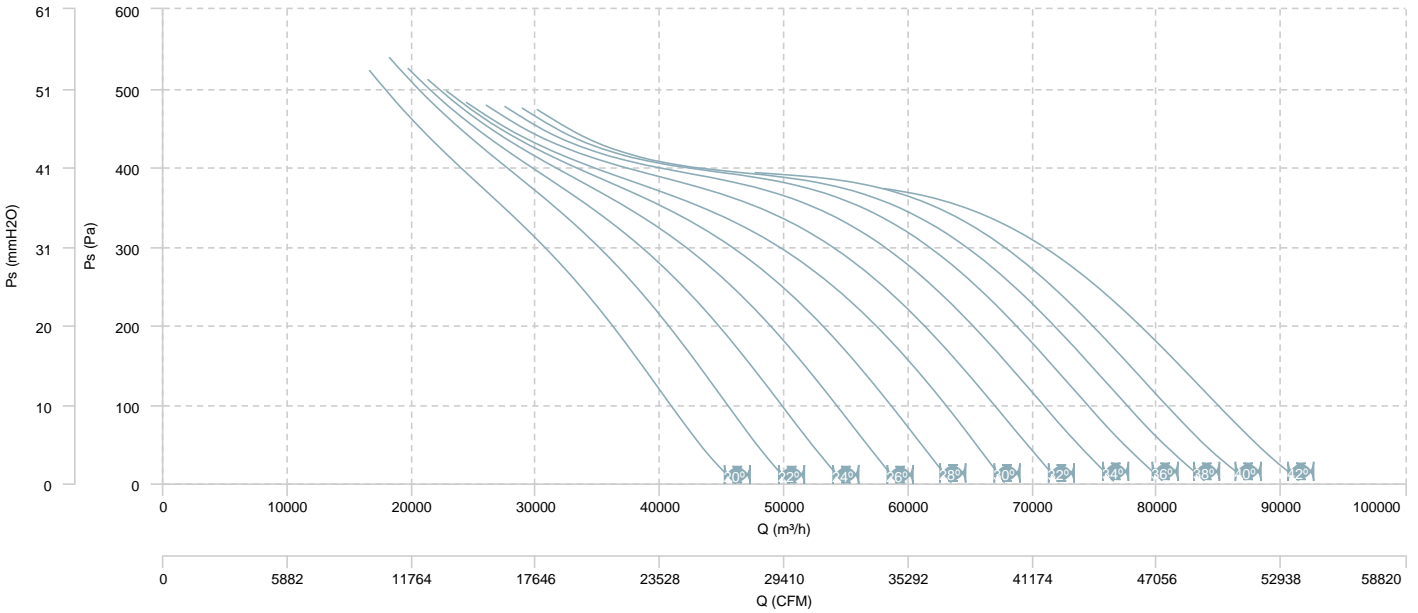

**AIR FLOW - MECHANICAL POWER**

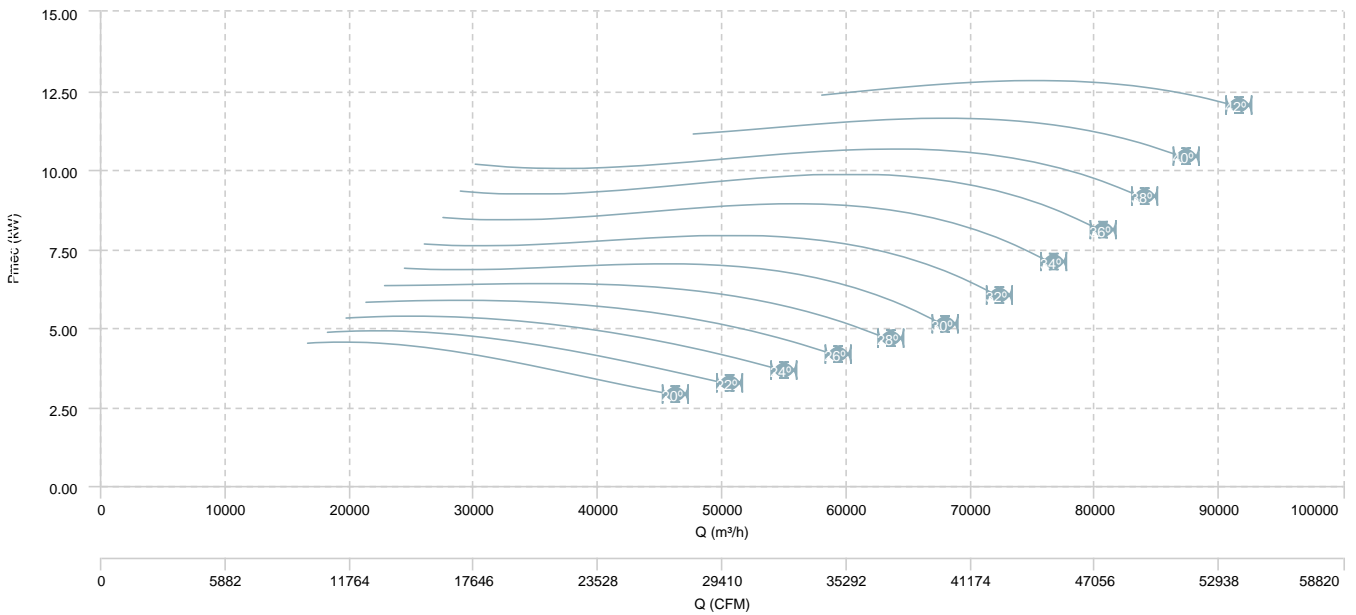

HCFX 125 T4/T8 (A3:4) F400

**AIR FLOW - PRESSURE (4 poles)**

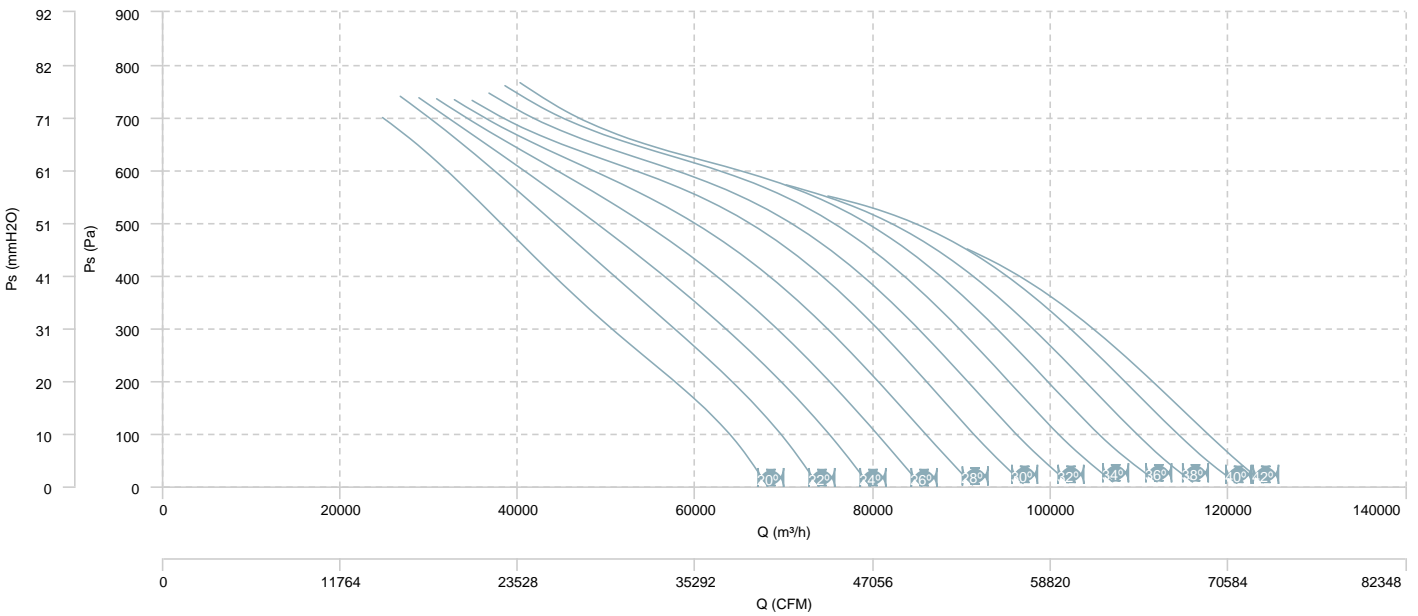

**AIR FLOW - MECHANICAL POWER (4 poles)**

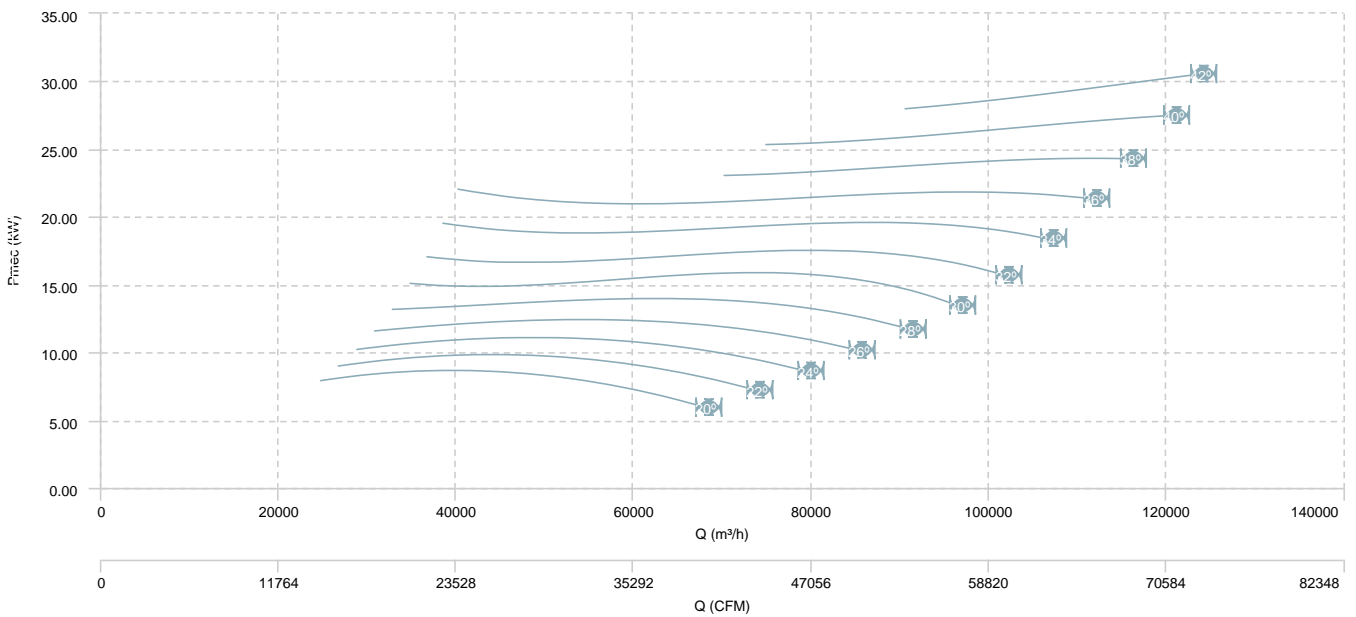

HCFX 125 T4/T8 (A3:4) F400

**AIR FLOW - PRESSURE (8 poles)**

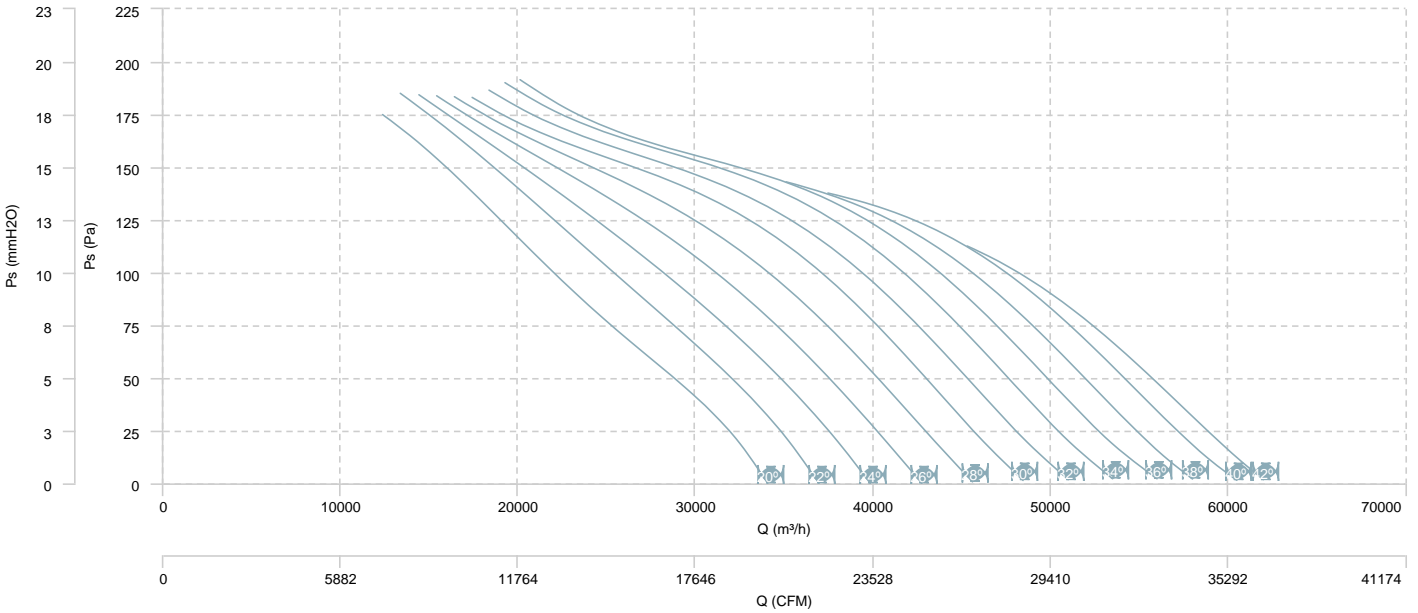

**AIR FLOW - MECHANICAL POWER (8 poles)**

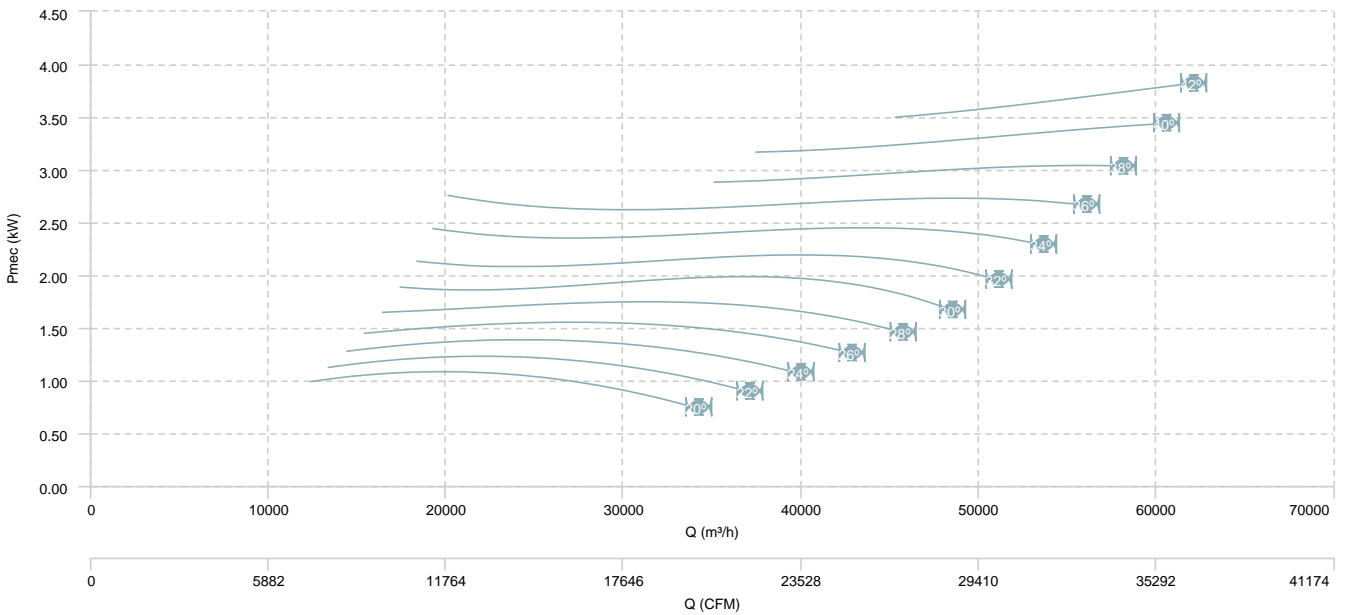

HCFX 125 T4/T8 (A3:8) F400

**AIR FLOW - PRESSURE (4 poles)**

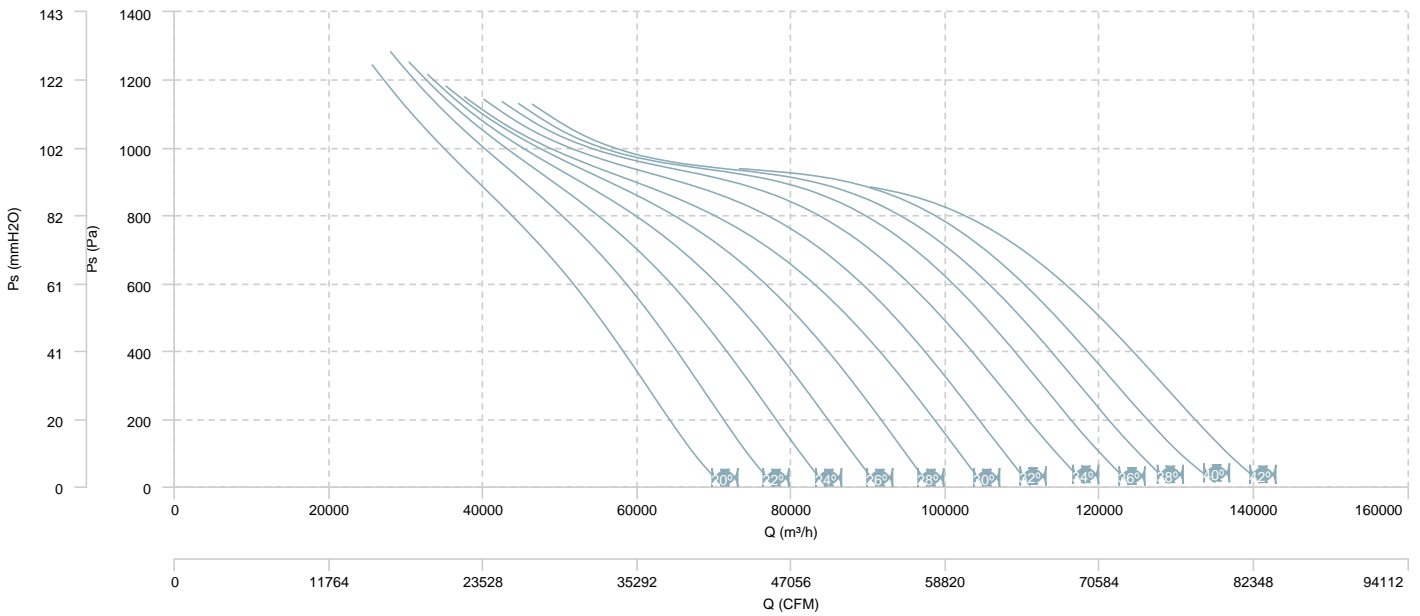

**AIR FLOW - MECHANICAL POWER (4 poles)**

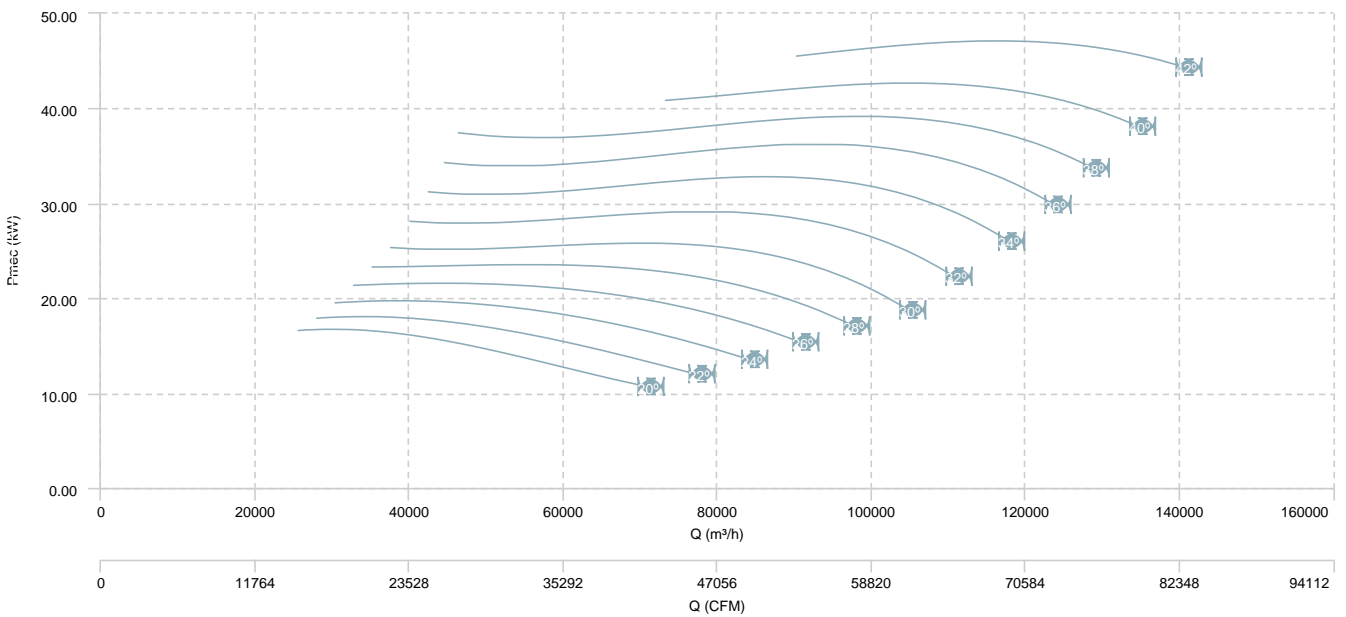

HCFX 125 T4/T8 (A3:8) F400

AIR FLOW - PRESSURE (8 poles)

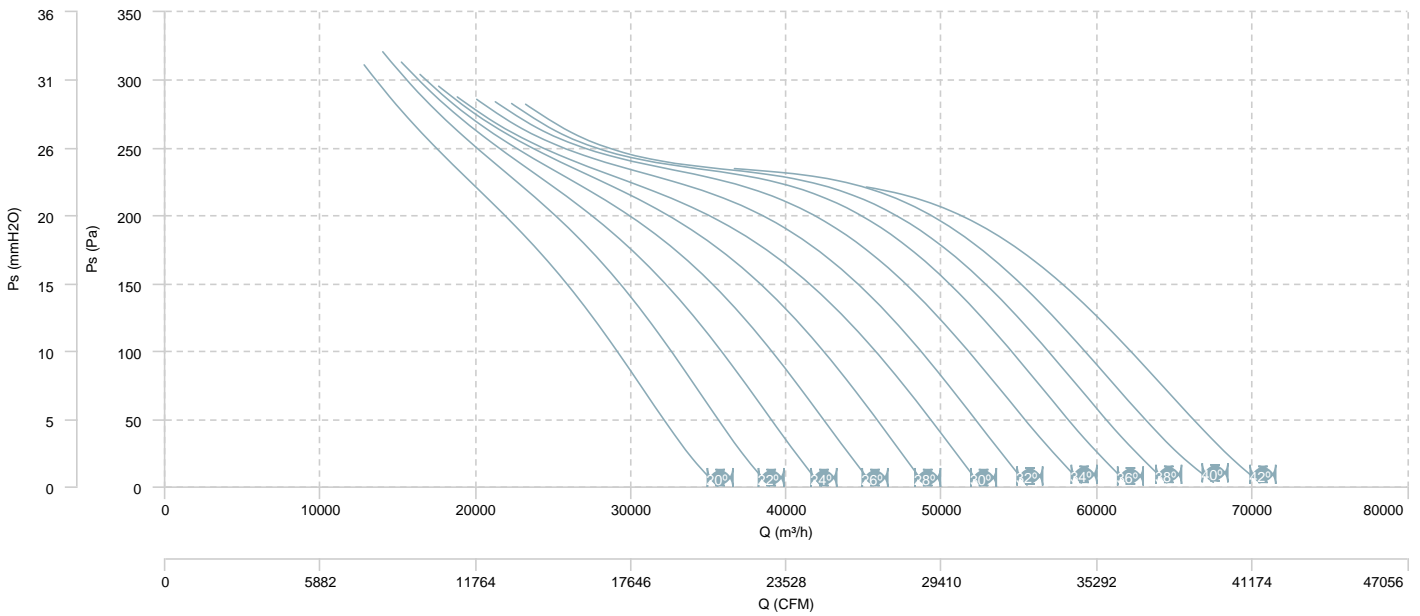

AIR FLOW - MECHANICAL POWER (8 poles)

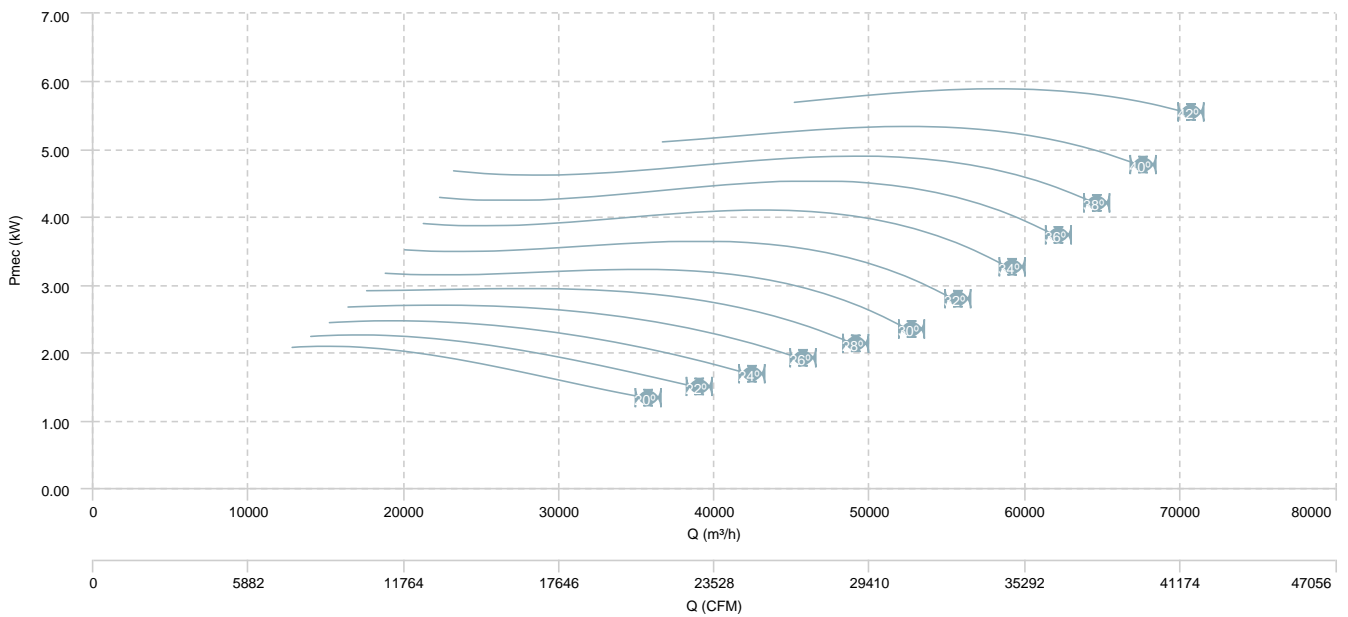



## Sound data

### Sound / 4 poles

Sound power Lw dB (A)										
Model		63 Hz	125 Hz	250 Hz	500 Hz	1000 Hz	2000 Hz	4000 Hz	8000 Hz	Total
HCFX 45 T4 (A5:6) F400 (20º)	Inlet	44	50	56	65	61	63	65	59	70
HCFX 45 T4 (A5:6) F400 (25º)	Inlet	46	51	58	65	64	65	67	59	72
HCFX 45 T4 (A5:6) F400 (27,5º)	Inlet	47	52	59	65	65	66	67	59	72
HCFX 45 T4 (A5:6) F400 (30º)	Inlet	49	54	61	65	67	68	69	60	74
HCFX 45 T4 (A5:6) F400 (32,5º)	Inlet	50	54	62	64	67	68	69	60	74
HCFX 45 T4 (A5:6) F400 (35º)	Inlet	50	54	62	63	68	68	70	59	74
HCFX 45 T4 (A5:6) F400 (37,5º)	Inlet	52	55	64	65	69	69	71	61	76
HCFX 45 T4 (A5:6) F400 (40º)	Inlet	53	57	65	67	70	70	72	63	77
HCFX 45 T4 (A5:6) F400 (42,5º)	Inlet	53	57	65	67	71	71	73	64	77
HCFX 50 T4 (A5:6) F400 (25º)	Inlet	45	52	57	62	65	67	69	61	73
HCFX 50 T4 (A5:6) F400 (27,5º)	Inlet	46	53	58	63	66	68	70	62	74
HCFX 50 T4 (A5:6) F400 (30º)	Inlet	48	53	60	64	67	68	71	62	75
HCFX 50 T4 (A5:6) F400 (32,5º)	Inlet	49	54	61	66	69	70	72	63	76
HCFX 50 T4 (A5:6) F400 (35º)	Inlet	50	55	62	68	70	71	73	64	78
HCFX 50 T4 (A5:6) F400 (37,5º)	Inlet	50	57	62	68	70	71	73	64	78
HCFX 50 T4 (A5:6) F400 (40º)	Inlet	50	57	62	68	70	71	73	64	78
HCFX 50 T4 (A5:6) F400 (42,5º)	Inlet	53	60	65	72	73	73	76	67	80
HCFX 50 T4 (A5:6) F400 (45º)	Inlet	53	60	65	73	74	74	76	68	81
HCFX 56 T4 (A5:6) F400 (20º)	Inlet	66	73	78	79	80	78	76	68	86
HCFX 56 T4 (A5:6) F400 (25º)	Inlet	53	62	67	73	75	75	76	67	82
HCFX 56 T4 (A5:6) F400 (30º)	Inlet	62	72	79	81	81	79	77	69	87
HCFX 56 T4 (A5:6) F400 (35º)	Inlet	50	62	67	73	74	75	76	68	81
HCFX 56 T4 (A5:6) F400 (40º)	Inlet	56	69	79	85	84	78	76	67	89
HCFX 56 T4 (A5:6) F400 (45º)	Inlet	60	73	88	94	91	80	76	67	96
HCFX 63 T4 (A5:6) F400 (20º)	Inlet	69	76	81	82	83	80	79	72	89
HCFX 63 T4 (A5:6) F400 (25º)	Inlet	54	63	68	73	77	76	76	70	83
HCFX 63 T4 (A5:6) F400 (30º)	Inlet	57	65	75	82	80	79	79	72	87
HCFX 63 T4 (A5:6) F400 (35º)	Inlet	53	65	70	74	78	77	79	72	84
HCFX 63 T4 (A5:6) F400 (40º)	Inlet	54	66	77	89	86	81	79	71	92
HCFX 63 T4 (A5:6) F400 (45º)	Inlet	55	66	82	100	92	84	79	71	100
HCFX 71 T4 (A5:6) F400 (20º)	Inlet	71	78	83	85	85	83	82	75	92
HCFX 71 T4 (A5:6) F400 (25º)	Inlet	58	68	74	78	81	82	82	73	88
HCFX 71 T4 (A5:6) F400 (30º)	Inlet	60	68	75	81	82	81	81	72	87
HCFX 71 T4 (A5:6) F400 (35º)	Inlet	53	65	70	75	78	79	80	71	84
HCFX 71 T4 (A5:6) F400 (40º)	Inlet	57	68	83	92	88	83	81	72	95

Sound power Lw dB (A)										
Model		63 Hz	125 Hz	250 Hz	500 Hz	1000 Hz	2000 Hz	4000 Hz	8000 Hz	Total
HCFX 71 T4 (A5:6) F400 (45 <sup>o</sup> )	Inlet	61	70	92	105	96	87	83	72	105
HCFX 80 T4 (A5:6) F400 (20 <sup>o</sup> )	Inlet	74	81	86	88	88	86	85	78	94
HCFX 80 T4 (A5:6) F400 (25 <sup>o</sup> )	Inlet	61	68	74	79	81	81	82	74	88
HCFX 80 T4 (A5:6) F400 (30 <sup>o</sup> )	Inlet	61	72	79	89	87	85	85	77	93
HCFX 80 T4 (A5:6) F400 (35 <sup>o</sup> )	Inlet	58	70	76	84	89	87	87	78	94
HCFX 80 T4 (A5:6) F400 (40 <sup>o</sup> )	Inlet	59	72	88	93	90	86	84	76	97
HCFX 80 T4 (A5:6) F400 (45 <sup>o</sup> )	Inlet	60	74	97	100	91	86	82	75	102
HCFX 90 T4 (A3:4) F400 (20 <sup>o</sup> )	Inlet	56	68	73	83	88	88	86	78	93
HCFX 90 T4 (A3:4) F400 (22 <sup>o</sup> )	Inlet	60	69	74	83	87	87	85	77	92
HCFX 90 T4 (A3:4) F400 (24 <sup>o</sup> )	Inlet	63	70	75	83	86	86	85	77	91
HCFX 90 T4 (A3:4) F400 (26 <sup>o</sup> )	Inlet	64	71	77	83	85	85	84	76	91
HCFX 90 T4 (A3:4) F400 (28 <sup>o</sup> )	Inlet	65	72	78	82	83	84	84	76	90
HCFX 90 T4 (A3:4) F400 (30 <sup>o</sup> )	Inlet	66	73	79	82	82	83	83	75	89
HCFX 90 T4 (A3:4) F400 (32 <sup>o</sup> )	Inlet	66	73	78	82	83	83	83	74	89
HCFX 90 T4 (A3:4) F400 (34 <sup>o</sup> )	Inlet	65	72	78	81	83	84	82	74	89
HCFX 90 T4 (A3:4) F400 (36 <sup>o</sup> )	Inlet	66	73	78	81	84	84	82	74	90
HCFX 90 T4 (A3:4) F400 (38 <sup>o</sup> )	Inlet	67	74	79	82	85	85	83	75	91
HCFX 90 T4 (A3:4) F400 (40 <sup>o</sup> )	Inlet	68	75	80	82	87	85	84	77	91
HCFX 90 T4 (A3:4) F400 (42 <sup>o</sup> )	Inlet	69	76	82	84	88	86	84	78	93
HCFX 90 T4 (A3:8) F400 (20 <sup>o</sup> )	Inlet	69	81	90	91	93	88	88	78	98
HCFX 90 T4 (A3:8) F400 (22 <sup>o</sup> )	Inlet	69	80	88	90	92	88	88	78	97
HCFX 90 T4 (A3:8) F400 (24 <sup>o</sup> )	Inlet	69	79	86	89	91	88	88	78	96
HCFX 90 T4 (A3:8) F400 (26 <sup>o</sup> )	Inlet	69	77	84	88	90	88	87	79	95
HCFX 90 T4 (A3:8) F400 (28 <sup>o</sup> )	Inlet	69	76	82	87	89	88	87	79	94
HCFX 90 T4 (A3:8) F400 (30 <sup>o</sup> )	Inlet	68	75	80	86	88	88	87	79	94
HCFX 90 T4 (A3:8) F400 (32 <sup>o</sup> )	Inlet	67	74	80	85	87	88	86	78	93
HCFX 90 T4 (A3:8) F400 (34 <sup>o</sup> )	Inlet	66	74	79	84	86	87	85	77	92
HCFX 90 T4 (A3:8) F400 (36 <sup>o</sup> )	Inlet	67	74	80	83	86	87	85	77	92
HCFX 90 T4 (A3:8) F400 (38 <sup>o</sup> )	Inlet	69	76	81	83	87	87	84	77	92
HCFX 90 T4 (A3:8) F400 (40 <sup>o</sup> )	Inlet	70	77	83	84	88	87	84	77	93
HCFX 90 T4 (A3:8) F400 (42 <sup>o</sup> )	Inlet	70	78	83	84	88	88	85	78	93
HCFX 100 T4 (A3:4) F400 (20 <sup>o</sup> )	Inlet	66	76	81	88	91	92	93	90	98
HCFX 100 T4 (A3:4) F400 (22 <sup>o</sup> )	Inlet	66	76	82	88	91	92	93	90	98
HCFX 100 T4 (A3:4) F400 (24 <sup>o</sup> )	Inlet	67	76	81	87	91	92	93	89	98
HCFX 100 T4 (A3:4) F400 (26 <sup>o</sup> )	Inlet	67	75	81	87	90	91	93	88	97
HCFX 100 T4 (A3:4) F400 (28 <sup>o</sup> )	Inlet	67	75	81	86	90	91	93	87	97
HCFX 100 T4 (A3:4) F400 (30 <sup>o</sup> )	Inlet	68	74	81	86	90	91	93	86	97
HCFX 100 T4 (A3:4) F400 (32 <sup>o</sup> )	Inlet	68	74	81	86	89	90	92	86	96
HCFX 100 T4 (A3:4) F400 (34 <sup>o</sup> )	Inlet	69	73	81	85	88	90	91	85	96

Sound power Lw dB (A)											
Model		63 Hz	125 Hz	250 Hz	500 Hz	1000 Hz	2000 Hz	4000 Hz	8000 Hz	Total	
HCFX 100 T4 (A3:4) F400 (36º)	Inlet	69	73	81	86	88	90	91	85	96	
HCFX 100 T4 (A3:4) F400 (38º)	Inlet	68	74	81	86	89	90	92	85	96	
HCFX 100 T4 (A3:4) F400 (40º)	Inlet	68	75	81	87	90	91	92	86	97	
HCFX 100 T4 (A3:4) F400 (42º)	Inlet	69	77	83	88	92	92	93	87	98	
HCFX 100 T4 (A3:8) F400 (20º)	Inlet	72	81	92	102	100	99	100	95	107	
HCFX 100 T4 (A3:8) F400 (22º)	Inlet	72	80	91	100	99	98	99	94	106	
HCFX 100 T4 (A3:8) F400 (24º)	Inlet	72	79	89	97	97	97	98	93	104	
HCFX 100 T4 (A3:8) F400 (26º)	Inlet	72	79	88	95	96	96	97	92	103	
HCFX 100 T4 (A3:8) F400 (28º)	Inlet	72	79	87	93	96	95	96	91	102	
HCFX 100 T4 (A3:8) F400 (30º)	Inlet	72	79	86	91	95	95	96	90	101	
HCFX 100 T4 (A3:8) F400 (32º)	Inlet	71	79	84	90	93	94	95	89	100	
HCFX 100 T4 (A3:8) F400 (34º)	Inlet	71	78	83	88	92	93	94	88	99	
HCFX 100 T4 (A3:8) F400 (36º)	Inlet	70	77	82	87	91	93	94	87	99	
HCFX 100 T4 (A3:8) F400 (38º)	Inlet	71	78	83	88	92	94	94	88	99	
HCFX 100 T4 (A3:8) F400 (40º)	Inlet	71	79	84	89	92	94	95	89	100	
HCFX 100 T4 (A3:8) F400 (42º)	Inlet	72	79	84	89	93	94	95	89	100	
HCFX 112 T4 (A3:4) F400 (20º)	Inlet	66	78	83	90	94	94	96	92	101	
HCFX 112 T4 (A3:4) F400 (22º)	Inlet	68	79	84	90	94	95	96	92	102	
HCFX 112 T4 (A3:4) F400 (24º)	Inlet	69	78	83	90	93	94	96	91	101	
HCFX 112 T4 (A3:4) F400 (26º)	Inlet	70	78	83	89	93	94	95	90	100	
HCFX 112 T4 (A3:4) F400 (28º)	Inlet	71	78	83	89	92	93	95	89	99	
HCFX 112 T4 (A3:4) F400 (30º)	Inlet	71	78	83	88	92	93	94	88	99	
HCFX 112 T4 (A3:4) F400 (32º)	Inlet	70	77	82	88	91	92	94	87	98	
HCFX 112 T4 (A3:4) F400 (34º)	Inlet	70	76	82	87	90	92	93	86	98	
HCFX 112 T4 (A3:4) F400 (36º)	Inlet	71	76	83	87	90	92	93	86	98	
HCFX 112 T4 (A3:4) F400 (38º)	Inlet	71	77	83	88	91	92	93	87	98	
HCFX 112 T4 (A3:4) F400 (40º)	Inlet	72	79	84	89	91	93	94	87	99	
HCFX 112 T4 (A3:4) F400 (42º)	Inlet	72	79	84	89	92	94	94	88	99	
HCFX 112 T4 (A3:8) F400 (20º)	Inlet	73	82	92	101	101	103	103	97	109	
HCFX 112 T4 (A3:8) F400 (22º)	Inlet	73	81	91	99	100	102	102	96	107	
HCFX 112 T4 (A3:8) F400 (24º)	Inlet	73	81	90	97	99	101	101	95	106	
HCFX 112 T4 (A3:8) F400 (26º)	Inlet	74	81	89	96	98	100	100	94	106	
HCFX 112 T4 (A3:8) F400 (28º)	Inlet	74	81	88	94	98	99	99	94	105	
HCFX 112 T4 (A3:8) F400 (30º)	Inlet	74	80	87	93	97	99	99	93	104	
HCFX 112 T4 (A3:8) F400 (32º)	Inlet	74	81	86	91	96	97	97	91	103	
HCFX 112 T4 (A3:8) F400 (34º)	Inlet	73	80	85	90	94	96	96	89	101	
HCFX 112 T4 (A3:8) F400 (36º)	Inlet	73	80	85	90	93	95	95	89	101	
HCFX 112 T4 (A3:8) F400 (38º)	Inlet	73	80	85	90	94	96	95	89	101	
HCFX 112 T4 (A3:8) F400 (40º)	Inlet	74	81	86	90	94	96	95	90	102	

Sound power Lw dB (A)											
Model		63 Hz	125 Hz	250 Hz	500 Hz	1000 Hz	2000 Hz	4000 Hz	8000 Hz	Total	
HCFX 112 T4 (A3:8) F400 (42 <sup>o</sup> )	Inlet	73	80	85	91	94	96	95	89	101	
HCFX 125 T4 (A3:4) F400 (20 <sup>o</sup> )	Inlet	72	85	90	98	102	102	104	101	109	
HCFX 125 T4 (A3:4) F400 (22 <sup>o</sup> )	Inlet	75	86	91	98	102	103	105	101	109	
HCFX 125 T4 (A3:4) F400 (24 <sup>o</sup> )	Inlet	75	85	90	96	100	101	103	98	107	
HCFX 125 T4 (A3:4) F400 (26 <sup>o</sup> )	Inlet	76	84	89	94	98	99	101	96	106	
HCFX 125 T4 (A3:4) F400 (28 <sup>o</sup> )	Inlet	75	82	87	93	96	98	99	93	104	
HCFX 125 T4 (A3:4) F400 (30 <sup>o</sup> )	Inlet	74	81	86	91	95	96	97	91	102	
HCFX 125 T4 (A3:4) F400 (32 <sup>o</sup> )	Inlet	74	81	86	90	94	96	96	90	102	
HCFX 125 T4 (A3:4) F400 (34 <sup>o</sup> )	Inlet	73	80	85	90	93	95	96	88	101	
HCFX 125 T4 (A3:4) F400 (36 <sup>o</sup> )	Inlet	74	81	86	90	93	95	96	88	101	
HCFX 125 T4 (A3:4) F400 (38 <sup>o</sup> )	Inlet	74	81	86	91	93	95	96	89	101	
HCFX 125 T4 (A3:4) F400 (40 <sup>o</sup> )	Inlet	75	82	87	91	93	96	96	89	102	
HCFX 125 T4 (A3:4) F400 (42 <sup>o</sup> )	Inlet	75	82	87	92	94	96	96	90	102	
HCFX 125 T4 (A3:8) F400 (20 <sup>o</sup> )	Inlet	78	86	93	103	108	111	110	105	115	
HCFX 125 T4 (A3:8) F400 (22 <sup>o</sup> )	Inlet	79	86	93	102	107	110	109	104	114	
HCFX 125 T4 (A3:8) F400 (24 <sup>o</sup> )	Inlet	78	85	92	100	106	108	108	102	113	
HCFX 125 T4 (A3:8) F400 (26 <sup>o</sup> )	Inlet	78	85	91	98	104	106	106	100	111	
HCFX 125 T4 (A3:8) F400 (28 <sup>o</sup> )	Inlet	78	84	91	97	102	105	105	98	110	
HCFX 125 T4 (A3:8) F400 (30 <sup>o</sup> )	Inlet	77	83	90	96	101	103	104	97	108	
HCFX 125 T4 (A3:8) F400 (32 <sup>o</sup> )	Inlet	77	83	89	95	99	102	102	94	107	
HCFX 125 T4 (A3:8) F400 (34 <sup>o</sup> )	Inlet	77	83	89	94	97	99	100	92	105	
HCFX 125 T4 (A3:8) F400 (36 <sup>o</sup> )	Inlet	77	83	89	93	96	98	98	91	104	
HCFX 125 T4 (A3:8) F400 (38 <sup>o</sup> )	Inlet	76	83	88	93	96	98	97	91	104	
HCFX 125 T4 (A3:8) F400 (40 <sup>o</sup> )	Inlet	76	83	88	93	96	98	97	90	103	
HCFX 125 T4 (A3:8) F400 (42 <sup>o</sup> )	Inlet	76	83	88	93	96	98	96	90	103	

## Sound / 6 poles

Sound power Lw dB (A)											
Model		63 Hz	125 Hz	250 Hz	500 Hz	1000 Hz	2000 Hz	4000 Hz	8000 Hz	Total	
HCFX 45 T6 (A5:6) F400 (25 <sup>o</sup> )	Inlet	37	42	49	55	54	55	57	50	62	
HCFX 45 T6 (A5:6) F400 (27,5 <sup>o</sup> )	Inlet	38	43	50	55	55	56	58	50	63	
HCFX 45 T6 (A5:6) F400 (30 <sup>o</sup> )	Inlet	40	44	52	55	57	58	59	50	64	
HCFX 45 T6 (A5:6) F400 (32,5 <sup>o</sup> )	Inlet	40	44	52	55	58	58	60	50	65	
HCFX 45 T6 (A5:6) F400 (35 <sup>o</sup> )	Inlet	41	45	53	54	59	59	60	50	65	
HCFX 45 T6 (A5:6) F400 (37,5 <sup>o</sup> )	Inlet	42	46	54	56	60	60	61	52	66	
HCFX 45 T6 (A5:6) F400 (40 <sup>o</sup> )	Inlet	44	47	56	57	61	61	63	54	67	
HCFX 45 T6 (A5:6) F400 (42,5 <sup>o</sup> )	Inlet	43	47	55	58	62	62	63	55	68	

Sound power Lw dB (A)										
Model		63 Hz	125 Hz	250 Hz	500 Hz	1000 Hz	2000 Hz	4000 Hz	8000 Hz	Total
HCFX 45 T6 (A5:6) F400 (45º)	Inlet	43	47	55	58	62	62	63	55	68
HCFX 50 T6 (A5:6) F400 (25º)	Inlet	36	43	48	53	55	58	60	52	64
HCFX 50 T6 (A5:6) F400 (27,5º)	Inlet	37	43	49	53	56	58	61	52	64
HCFX 50 T6 (A5:6) F400 (30º)	Inlet	39	44	51	55	58	59	62	53	66
HCFX 50 T6 (A5:6) F400 (32,5º)	Inlet	40	45	52	57	59	60	63	54	67
HCFX 50 T6 (A5:6) F400 (35º)	Inlet	40	45	52	59	61	62	64	55	68
HCFX 50 T6 (A5:6) F400 (37,5º)	Inlet	41	48	53	59	61	62	64	55	68
HCFX 50 T6 (A5:6) F400 (40º)	Inlet	41	48	53	59	61	62	64	55	68
HCFX 50 T6 (A5:6) F400 (42,5º)	Inlet	43	50	55	62	63	64	66	58	71
HCFX 50 T6 (A5:6) F400 (45º)	Inlet	44	51	56	64	65	65	67	59	72
HCFX 56 T6 (A5:6) F400 (20º)	Inlet	63	70	75	76	77	75	73	65	82
HCFX 56 T6 (A5:6) F400 (25º)	Inlet	50	59	64	70	72	72	73	64	78
HCFX 56 T6 (A5:6) F400 (30º)	Inlet	58	68	75	77	78	76	74	66	83
HCFX 56 T6 (A5:6) F400 (35º)	Inlet	47	58	63	69	70	71	72	64	78
HCFX 56 T6 (A5:6) F400 (40º)	Inlet	53	66	76	81	81	75	73	64	85
HCFX 56 T6 (A5:6) F400 (45º)	Inlet	57	69	84	90	88	77	73	63	93
HCFX 63 T6 (A5:6) F400 (20º)	Inlet	66	73	78	79	80	77	76	69	85
HCFX 63 T6 (A5:6) F400 (25º)	Inlet	51	60	65	70	74	73	73	67	79
HCFX 63 T6 (A5:6) F400 (30º)	Inlet	54	62	72	79	77	76	76	69	83
HCFX 63 T6 (A5:6) F400 (35º)	Inlet	50	62	67	71	75	74	76	69	81
HCFX 63 T6 (A5:6) F400 (40º)	Inlet	51	63	74	86	83	78	76	68	88
HCFX 63 T6 (A5:6) F400 (45º)	Inlet	52	63	79	96	88	81	76	67	97
HCFX 71 T6 (A5:6) F400 (20º)	Inlet	68	75	80	82	82	80	79	72	88
HCFX 71 T6 (A5:6) F400 (25º)	Inlet	55	65	71	75	78	79	79	70	84
HCFX 71 T6 (A5:6) F400 (30º)	Inlet	57	65	71	77	78	78	77	68	84
HCFX 71 T6 (A5:6) F400 (35º)	Inlet	49	61	66	71	74	75	76	67	81
HCFX 71 T6 (A5:6) F400 (40º)	Inlet	54	64	79	89	85	80	78	68	91
HCFX 71 T6 (A5:6) F400 (45º)	Inlet	57	66	88	101	92	83	79	69	102
HCFX 80 T6 (A5:6) F400 (20º)	Inlet	71	78	83	85	85	83	82	75	91
HCFX 80 T6 (A5:6) F400 (25º)	Inlet	58	65	71	76	78	78	79	71	84
HCFX 80 T6 (A5:6) F400 (30º)	Inlet	58	69	76	86	84	82	82	74	90
HCFX 80 T6 (A5:6) F400 (35º)	Inlet	55	67	73	81	86	84	84	75	90
HCFX 80 T6 (A5:6) F400 (40º)	Inlet	56	69	85	90	87	83	81	73	93
HCFX 80 T6 (A5:6) F400 (45º)	Inlet	56	70	93	96	87	82	79	71	98
HCFX 90 T6 (A3:4) F400 (20º)	Inlet	47	58	64	74	78	78	77	68	83
HCFX 90 T6 (A3:4) F400 (22º)	Inlet	51	59	65	74	77	77	76	68	83
HCFX 90 T6 (A3:4) F400 (24º)	Inlet	53	60	66	73	76	76	75	67	82
HCFX 90 T6 (A3:4) F400 (26º)	Inlet	55	62	67	73	75	75	75	67	81
HCFX 90 T6 (A3:4) F400 (28º)	Inlet	56	63	68	73	74	74	74	66	81

Sound power Lw dB (A)										
Model		63 Hz	125 Hz	250 Hz	500 Hz	1000 Hz	2000 Hz	4000 Hz	8000 Hz	Total
HCFX 90 T6 (A3:4) F400 (30 <sup>º</sup> )	Inlet	57	64	69	73	73	73	74	66	80
HCFX 90 T6 (A3:4) F400 (32 <sup>º</sup> )	Inlet	56	63	69	72	73	74	73	65	80
HCFX 90 T6 (A3:4) F400 (34 <sup>º</sup> )	Inlet	56	63	68	72	74	75	73	64	80
HCFX 90 T6 (A3:4) F400 (36 <sup>º</sup> )	Inlet	56	63	69	72	75	75	73	65	80
HCFX 90 T6 (A3:4) F400 (38 <sup>º</sup> )	Inlet	57	64	70	72	76	75	74	66	81
HCFX 90 T6 (A3:4) F400 (40 <sup>º</sup> )	Inlet	58	66	71	73	77	75	74	67	82
HCFX 90 T6 (A3:4) F400 (42 <sup>º</sup> )	Inlet	60	67	72	74	78	77	75	68	83
HCFX 90 T6 (A3:8) F400 (20 <sup>º</sup> )	Inlet	59	72	81	82	84	78	79	68	88
HCFX 90 T6 (A3:8) F400 (22 <sup>º</sup> )	Inlet	60	70	79	81	83	78	78	69	87
HCFX 90 T6 (A3:8) F400 (24 <sup>º</sup> )	Inlet	60	69	77	80	82	78	78	69	86
HCFX 90 T6 (A3:8) F400 (26 <sup>º</sup> )	Inlet	60	68	75	79	81	79	78	69	86
HCFX 90 T6 (A3:8) F400 (28 <sup>º</sup> )	Inlet	60	67	73	78	80	79	78	69	85
HCFX 90 T6 (A3:8) F400 (30 <sup>º</sup> )	Inlet	58	65	71	77	79	79	78	70	84
HCFX 90 T6 (A3:8) F400 (32 <sup>º</sup> )	Inlet	58	65	70	75	78	78	77	69	84
HCFX 90 T6 (A3:8) F400 (34 <sup>º</sup> )	Inlet	57	64	70	74	77	78	76	68	83
HCFX 90 T6 (A3:8) F400 (36 <sup>º</sup> )	Inlet	58	65	70	74	77	78	75	67	83
HCFX 90 T6 (A3:8) F400 (38 <sup>º</sup> )	Inlet	59	66	72	74	78	78	75	68	83
HCFX 90 T6 (A3:8) F400 (40 <sup>º</sup> )	Inlet	61	68	73	74	78	78	75	68	83
HCFX 90 T6 (A3:8) F400 (42 <sup>º</sup> )	Inlet	61	68	74	75	79	79	75	68	84
HCFX 100 T6 (A3:4) F400 (20 <sup>º</sup> )	Inlet	56	67	72	78	82	83	84	81	89
HCFX 100 T6 (A3:4) F400 (22 <sup>º</sup> )	Inlet	57	67	72	78	82	83	84	80	89
HCFX 100 T6 (A3:4) F400 (24 <sup>º</sup> )	Inlet	57	66	72	78	82	82	84	79	89
HCFX 100 T6 (A3:4) F400 (26 <sup>º</sup> )	Inlet	57	66	71	77	81	82	83	78	88
HCFX 100 T6 (A3:4) F400 (28 <sup>º</sup> )	Inlet	58	65	71	77	81	81	83	78	88
HCFX 100 T6 (A3:4) F400 (30 <sup>º</sup> )	Inlet	58	65	71	77	80	81	83	77	87
HCFX 100 T6 (A3:4) F400 (32 <sup>º</sup> )	Inlet	59	64	71	76	79	81	83	76	87
HCFX 100 T6 (A3:4) F400 (34 <sup>º</sup> )	Inlet	59	63	71	76	79	80	82	76	86
HCFX 100 T6 (A3:4) F400 (36 <sup>º</sup> )	Inlet	59	64	71	76	79	80	82	76	86
HCFX 100 T6 (A3:4) F400 (38 <sup>º</sup> )	Inlet	59	65	72	77	80	81	82	76	87
HCFX 100 T6 (A3:4) F400 (40 <sup>º</sup> )	Inlet	59	66	72	77	81	81	83	76	87
HCFX 100 T6 (A3:4) F400 (42 <sup>º</sup> )	Inlet	60	67	73	79	82	82	83	78	89
HCFX 100 T6 (A3:8) F400 (20 <sup>º</sup> )	Inlet	63	71	83	92	91	89	90	86	97
HCFX 100 T6 (A3:8) F400 (22 <sup>º</sup> )	Inlet	63	71	82	90	89	88	89	85	96
HCFX 100 T6 (A3:8) F400 (24 <sup>º</sup> )	Inlet	62	70	80	88	88	87	88	83	94
HCFX 100 T6 (A3:8) F400 (26 <sup>º</sup> )	Inlet	62	70	79	86	87	87	87	82	93
HCFX 100 T6 (A3:8) F400 (28 <sup>º</sup> )	Inlet	62	70	78	84	86	86	87	81	92
HCFX 100 T6 (A3:8) F400 (30 <sup>º</sup> )	Inlet	62	69	77	82	85	86	86	80	92
HCFX 100 T6 (A3:8) F400 (32 <sup>º</sup> )	Inlet	62	69	75	80	84	85	85	79	90
HCFX 100 T6 (A3:8) F400 (34 <sup>º</sup> )	Inlet	61	68	73	78	82	84	85	78	89

Sound power Lw dB (A)											
Model		63 Hz	125 Hz	250 Hz	500 Hz	1000 Hz	2000 Hz	4000 Hz	8000 Hz	Total	
HCFX 100 T6 (A3:8) F400 (36º)	Inlet	61	68	73	78	82	84	84	78	89	
HCFX 100 T6 (A3:8) F400 (38º)	Inlet	61	68	73	79	82	84	85	79	90	
HCFX 100 T6 (A3:8) F400 (40º)	Inlet	62	69	74	79	83	85	85	79	90	
HCFX 100 T6 (A3:8) F400 (42º)	Inlet	62	69	74	80	83	85	85	79	90	
HCFX 112 T6 (A3:4) F400 (20º)	Inlet	56	68	73	80	84	85	87	82	91	
HCFX 112 T6 (A3:4) F400 (22º)	Inlet	58	69	74	81	85	85	87	82	92	
HCFX 112 T6 (A3:4) F400 (24º)	Inlet	59	69	74	80	84	85	86	81	91	
HCFX 112 T6 (A3:4) F400 (26º)	Inlet	60	69	74	80	83	84	86	80	90	
HCFX 112 T6 (A3:4) F400 (28º)	Inlet	61	69	74	79	83	84	85	79	90	
HCFX 112 T6 (A3:4) F400 (30º)	Inlet	61	68	73	79	82	83	85	78	89	
HCFX 112 T6 (A3:4) F400 (32º)	Inlet	61	67	73	78	81	83	84	78	89	
HCFX 112 T6 (A3:4) F400 (34º)	Inlet	61	66	73	78	81	82	84	77	88	
HCFX 112 T6 (A3:4) F400 (36º)	Inlet	61	67	73	78	81	82	84	77	88	
HCFX 112 T6 (A3:4) F400 (38º)	Inlet	62	68	74	78	81	83	84	77	89	
HCFX 112 T6 (A3:4) F400 (40º)	Inlet	63	69	75	79	82	84	84	78	89	
HCFX 112 T6 (A3:4) F400 (42º)	Inlet	63	70	75	80	83	84	85	78	90	
HCFX 112 T6 (A3:8) F400 (20º)	Inlet	64	72	82	91	91	93	93	88	99	
HCFX 112 T6 (A3:8) F400 (22º)	Inlet	64	72	81	89	90	92	92	87	98	
HCFX 112 T6 (A3:8) F400 (24º)	Inlet	64	71	80	88	90	91	91	86	96	
HCFX 112 T6 (A3:8) F400 (26º)	Inlet	64	71	79	86	89	90	90	85	96	
HCFX 112 T6 (A3:8) F400 (28º)	Inlet	64	71	79	85	89	90	90	84	95	
HCFX 112 T6 (A3:8) F400 (30º)	Inlet	65	71	78	83	88	89	89	84	94	
HCFX 112 T6 (A3:8) F400 (32º)	Inlet	64	71	77	82	86	88	88	82	93	
HCFX 112 T6 (A3:8) F400 (34º)	Inlet	64	71	76	81	84	86	87	80	92	
HCFX 112 T6 (A3:8) F400 (36º)	Inlet	63	70	75	80	84	86	86	79	91	
HCFX 112 T6 (A3:8) F400 (38º)	Inlet	64	71	76	81	84	86	86	80	91	
HCFX 112 T6 (A3:8) F400 (40º)	Inlet	64	71	76	81	85	87	86	80	92	
HCFX 112 T6 (A3:8) F400 (42º)	Inlet	64	71	76	81	85	86	86	79	91	
HCFX 125 T6 (A3:4) F400 (20º)	Inlet	63	76	81	89	92	92	94	91	99	
HCFX 125 T6 (A3:4) F400 (22º)	Inlet	65	77	82	89	92	93	95	91	99	
HCFX 125 T6 (A3:4) F400 (24º)	Inlet	66	75	80	87	90	91	93	88	98	
HCFX 125 T6 (A3:4) F400 (26º)	Inlet	66	74	79	85	89	90	91	86	96	
HCFX 125 T6 (A3:4) F400 (28º)	Inlet	66	73	78	83	87	88	89	84	94	
HCFX 125 T6 (A3:4) F400 (30º)	Inlet	65	72	77	81	85	87	88	81	92	
HCFX 125 T6 (A3:4) F400 (32º)	Inlet	64	71	76	81	84	86	87	80	92	
HCFX 125 T6 (A3:4) F400 (34º)	Inlet	64	71	76	81	84	85	86	79	91	
HCFX 125 T6 (A3:4) F400 (36º)	Inlet	64	71	76	81	83	85	86	79	91	
HCFX 125 T6 (A3:4) F400 (38º)	Inlet	65	72	77	81	84	86	86	79	91	
HCFX 125 T6 (A3:4) F400 (40º)	Inlet	65	72	77	82	84	86	87	80	92	

Sound power Lw dB (A)										
Model		63 Hz	125 Hz	250 Hz	500 Hz	1000 Hz	2000 Hz	4000 Hz	8000 Hz	Total
HCFX 125 T6 (A3:4) F400 (42°)	Inlet	66	73	78	82	85	87	87	81	92
HCFX 125 T6 (A3:8) F400 (20°)	Inlet	69	77	84	93	98	101	101	95	106
HCFX 125 T6 (A3:8) F400 (22°)	Inlet	69	77	84	92	97	100	99	94	105
HCFX 125 T6 (A3:8) F400 (24°)	Inlet	69	76	83	90	96	98	98	92	103
HCFX 125 T6 (A3:8) F400 (26°)	Inlet	69	75	82	89	94	97	96	90	102
HCFX 125 T6 (A3:8) F400 (28°)	Inlet	68	74	81	87	93	95	95	89	100
HCFX 125 T6 (A3:8) F400 (30°)	Inlet	68	74	80	86	91	93	94	87	98
HCFX 125 T6 (A3:8) F400 (32°)	Inlet	68	74	80	85	90	92	92	85	97
HCFX 125 T6 (A3:8) F400 (34°)	Inlet	68	74	80	84	88	90	90	83	95
HCFX 125 T6 (A3:8) F400 (36°)	Inlet	67	74	79	84	87	89	89	82	94
HCFX 125 T6 (A3:8) F400 (38°)	Inlet	67	74	79	84	87	89	88	81	94
HCFX 125 T6 (A3:8) F400 (40°)	Inlet	67	74	79	83	87	89	87	81	93
HCFX 125 T6 (A3:8) F400 (42°)	Inlet	67	74	79	84	87	88	87	81	93

Sound / 4/8 poles

Sound power Lw dB (A)										
Model		63 Hz	125 Hz	250 Hz	500 Hz	1000 Hz	2000 Hz	4000 Hz	8000 Hz	Total
HCFX 45 T4/T8 (A5:6) F400 (20°)	Inlet	44	50	56	65	61	63	65	59	70
HCFX 45 T4/T8 (A5:6) F400 (25°)	Inlet	46	51	58	65	64	65	67	59	72
HCFX 45 T4/T8 (A5:6) F400 (27, 5°)	Inlet	47	52	59	65	65	66	67	59	72
HCFX 45 T4/T8 (A5:6) F400 (30°)	Inlet	49	54	61	65	67	68	69	60	74
HCFX 45 T4/T8 (A5:6) F400 (32, 5°)	Inlet	50	54	62	64	67	68	69	60	74
HCFX 45 T4/T8 (A5:6) F400 (35°)	Inlet	50	54	62	63	68	68	70	59	74
HCFX 45 T4/T8 (A5:6) F400 (37, 5°)	Inlet	52	55	64	65	69	69	71	61	76
HCFX 45 T4/T8 (A5:6) F400 (40°)	Inlet	53	57	65	67	70	70	72	63	77
HCFX 45 T4/T8 (A5:6) F400 (42, 5°)	Inlet	53	57	65	67	71	71	73	64	77
HCFX 50 T4/T8 (A5:6) F400 (25°)	Inlet	45	52	57	62	65	67	69	61	73
HCFX 50 T4/T8 (A5:6) F400 (27, 5°)	Inlet	46	53	58	63	66	68	70	62	74
HCFX 50 T4/T8 (A5:6) F400 (30°)	Inlet	48	53	60	64	67	68	71	62	75
HCFX 50 T4/T8 (A5:6) F400 (32, 5°)	Inlet	49	54	61	66	69	70	72	63	76
HCFX 50 T4/T8 (A5:6) F400 (35°)	Inlet	50	55	62	68	70	71	73	64	78
HCFX 50 T4/T8 (A5:6) F400 (37, 5°)	Inlet	50	57	62	68	70	71	73	64	78



Sound power Lw dB (A)										
Model		63 Hz	125 Hz	250 Hz	500 Hz	1000 Hz	2000 Hz	4000 Hz	8000 Hz	Total
HCFX 50 T4/T8 (A5:6) F400 (40°)	Inlet	50	57	62	68	70	71	73	64	78
HCFX 50 T4/T8 (A5:6) F400 (42, 5°)	Inlet	53	60	65	72	73	73	76	67	80
HCFX 50 T4/T8 (A5:6) F400 (45°)	Inlet	53	60	65	73	74	74	76	68	81
HCFX 56 T4/T8 (A5:6) F400 (710 - 20°)	Inlet	50	57	62	63	64	62	60	52	70
HCFX 56 T4/T8 (A5:6) F400 (710 - 25°)	Inlet	37	46	51	57	59	59	60	51	66
HCFX 56 T4/T8 (A5:6) F400 (710 - 30°)	Inlet	46	56	63	65	65	63	61	53	71
HCFX 56 T4/T8 (A5:6) F400 (710 - 35°)	Inlet	34	46	51	57	58	59	60	52	65
HCFX 56 T4/T8 (A5:6) F400 (710 - 40°)	Inlet	40	53	63	69	68	62	60	51	73
HCFX 56 T4/T8 (A5:6) F400 (710 - 45°)	Inlet	45	57	72	78	75	64	60	51	81
HCFX 56 T4/T8 (A5:6) F400 (4p - 20°)	Inlet	66	73	78	79	80	78	76	68	86
HCFX 56 T4/T8 (A5:6) F400 (4p - 25°)	Inlet	53	62	67	73	75	75	76	67	82
HCFX 56 T4/T8 (A5:6) F400 (4p - 30°)	Inlet	62	72	79	81	81	79	77	69	87
HCFX 56 T4/T8 (A5:6) F400 (4p - 35°)	Inlet	50	62	67	73	74	75	76	68	81
HCFX 56 T4/T8 (A5:6) F400 (4p - 40°)	Inlet	56	69	79	85	84	78	76	67	89
HCFX 56 T4/T8 (A5:6) F400 (4p - 45°)	Inlet	60	73	88	94	91	80	76	67	96
HCFX 63 T4/T8 (A5:6) F400 (710 - 20°)	Inlet	53	60	65	66	67	64	63	56	73
HCFX 63 T4/T8 (A5:6) F400 (710 - 25°)	Inlet	39	48	53	58	62	61	61	54	67
HCFX 63 T4/T8 (A5:6) F400 (710 - 30°)	Inlet	41	49	59	66	64	63	63	56	71
HCFX 63 T4/T8 (A5:6) F400 (710 - 35°)	Inlet	37	49	54	58	62	61	63	56	68
HCFX 63 T4/T8 (A5:6) F400 (710 - 40°)	Inlet	38	50	62	73	70	65	63	55	76
HCFX 63 T4/T8 (A5:6) F400 (710 - 45°)	Inlet	39	50	67	84	76	68	63	55	85
HCFX 63 T4/T8 (A5:6) F400 (4p - 20°)	Inlet	69	76	81	82	83	80	79	72	89
HCFX 63 T4/T8 (A5:6) F400 (4p - 25°)	Inlet	54	63	68	73	77	76	76	70	83

Sound power Lw dB (A)										
Model		63 Hz	125 Hz	250 Hz	500 Hz	1000 Hz	2000 Hz	4000 Hz	8000 Hz	Total
HCFX 63 T4/T8 (A5:6) F400 (4p - 30°)	Inlet	57	65	75	82	80	79	79	72	87
HCFX 63 T4/T8 (A5:6) F400 (4p - 35°)	Inlet	53	65	70	74	78	77	79	72	84
HCFX 63 T4/T8 (A5:6) F400 (4p - 40°)	Inlet	54	66	77	89	86	81	79	71	92
HCFX 63 T4/T8 (A5:6) F400 (4p - 45°)	Inlet	55	66	82	100	92	84	79	71	100
HCFX 71 T4/T8 (A5:6) F400 (710 - 20°)	Inlet	56	63	68	70	70	68	67	60	76
HCFX 71 T4/T8 (A5:6) F400 (710 - 25°)	Inlet	43	52	58	62	65	66	66	57	72
HCFX 71 T4/T8 (A5:6) F400 (710 - 30°)	Inlet	44	53	59	65	66	66	65	56	72
HCFX 71 T4/T8 (A5:6) F400 (710 - 35°)	Inlet	37	49	54	59	62	63	64	55	69
HCFX 71 T4/T8 (A5:6) F400 (710 - 40°)	Inlet	41	52	67	76	72	68	66	56	79
HCFX 71 T4/T8 (A5:6) F400 (710 - 45°)	Inlet	45	54	76	89	80	71	67	56	90
HCFX 71 T4/T8 (A5:6) F400 (4p - 20°)	Inlet	71	78	83	85	85	83	82	75	92
HCFX 71 T4/T8 (A5:6) F400 (4p - 25°)	Inlet	58	68	74	78	81	82	82	73	88
HCFX 71 T4/T8 (A5:6) F400 (4p - 30°)	Inlet	60	68	75	81	82	81	81	72	87
HCFX 71 T4/T8 (A5:6) F400 (4p - 35°)	Inlet	53	65	70	75	78	79	80	71	84
HCFX 71 T4/T8 (A5:6) F400 (4p - 40°)	Inlet	57	68	83	92	88	83	81	72	95
HCFX 71 T4/T8 (A5:6) F400 (4p - 45°)	Inlet	61	70	92	105	96	87	83	72	105
HCFX 80 T4/T8 (A5:6) F400 (710 - 20°)	Inlet	58	65	70	72	72	70	69	62	79
HCFX 80 T4/T8 (A5:6) F400 (710 - 25°)	Inlet	45	52	58	63	65	65	66	58	72
HCFX 80 T4/T8 (A5:6) F400 (710 - 30°)	Inlet	45	57	64	73	71	69	69	61	78
HCFX 80 T4/T8 (A5:6) F400 (710 - 35°)	Inlet	42	54	60	68	73	71	71	62	78
HCFX 80 T4/T8 (A5:6) F400 (710 - 40°)	Inlet	43	56	72	77	74	70	68	60	81
HCFX 80 T4/T8 (A5:6) F400 (710 - 45°)	Inlet	44	58	81	84	75	70	66	59	86

Sound power Lw dB (A)										
Model		63 Hz	125 Hz	250 Hz	500 Hz	1000 Hz	2000 Hz	4000 Hz	8000 Hz	Total
HCFX 80 T4/T8 (A5:6) F400 (4p - 20°)	Inlet	74	81	86	88	88	86	85	78	94
HCFX 80 T4/T8 (A5:6) F400 (4p - 25°)	Inlet	61	68	74	79	81	81	82	74	88
HCFX 80 T4/T8 (A5:6) F400 (4p - 30°)	Inlet	61	72	79	89	87	85	85	77	93
HCFX 80 T4/T8 (A5:6) F400 (4p - 35°)	Inlet	58	70	76	84	89	87	87	78	94
HCFX 80 T4/T8 (A5:6) F400 (4p - 40°)	Inlet	59	72	88	93	90	86	84	76	97
HCFX 80 T4/T8 (A5:6) F400 (4p - 45°)	Inlet	60	74	97	100	91	86	82	75	102
HCFX 90 T4/T8 (A3:4) F400 (8p - 20°)	Inlet	41	52	57	67	72	72	70	62	77
HCFX 90 T4/T8 (A3:4) F400 (8p - 22°)	Inlet	44	53	58	67	71	71	70	61	76
HCFX 90 T4/T8 (A3:4) F400 (8p - 24°)	Inlet	47	54	60	67	70	70	69	61	75
HCFX 90 T4/T8 (A3:4) F400 (8p - 26°)	Inlet	48	55	61	67	69	69	68	60	75
HCFX 90 T4/T8 (A3:4) F400 (8p - 28°)	Inlet	49	56	62	67	68	68	68	60	74
HCFX 90 T4/T8 (A3:4) F400 (8p - 30°)	Inlet	50	57	63	66	67	67	67	59	74
HCFX 90 T4/T8 (A3:4) F400 (8p - 32°)	Inlet	50	57	62	66	67	67	67	59	74
HCFX 90 T4/T8 (A3:4) F400 (8p - 34°)	Inlet	49	56	62	65	67	68	66	58	74
HCFX 90 T4/T8 (A3:4) F400 (8p - 36°)	Inlet	50	57	62	65	68	69	67	58	74
HCFX 90 T4/T8 (A3:4) F400 (8p - 38°)	Inlet	51	58	63	66	69	69	67	60	75
HCFX 90 T4/T8 (A3:4) F400 (8p - 40°)	Inlet	52	59	65	67	71	69	68	61	76
HCFX 90 T4/T8 (A3:4) F400 (8p - 42°)	Inlet	53	60	66	68	72	70	69	62	77
HCFX 90 T4/T8 (A3:4) F400 (4p - 20°)	Inlet	56	68	73	83	88	88	86	78	93
HCFX 90 T4/T8 (A3:4) F400 (4p - 22°)	Inlet	60	69	74	83	87	87	85	77	92
HCFX 90 T4/T8 (A3:4) F400 (4p - 24°)	Inlet	63	70	75	83	86	86	85	77	91
HCFX 90 T4/T8 (A3:4) F400 (4p - 26°)	Inlet	64	71	77	83	85	85	84	76	91

Sound power Lw dB (A)										
Model		63 Hz	125 Hz	250 Hz	500 Hz	1000 Hz	2000 Hz	4000 Hz	8000 Hz	Total
HCFX 90 T4/T8 (A3:4) F400 (4p - 28°)	Inlet	65	72	78	82	83	84	84	76	90
HCFX 90 T4/T8 (A3:4) F400 (4p - 30°)	Inlet	66	73	79	82	82	83	83	75	89
HCFX 90 T4/T8 (A3:4) F400 (4p - 32°)	Inlet	66	73	78	82	83	83	83	74	89
HCFX 90 T4/T8 (A3:4) F400 (4p - 34°)	Inlet	65	72	78	81	83	84	82	74	89
HCFX 90 T4/T8 (A3:4) F400 (4p - 36°)	Inlet	66	73	78	81	84	84	82	74	90
HCFX 90 T4/T8 (A3:4) F400 (4p - 38°)	Inlet	67	74	79	82	85	85	83	75	91
HCFX 90 T4/T8 (A3:4) F400 (4p - 40°)	Inlet	68	75	80	82	87	85	84	77	91
HCFX 90 T4/T8 (A3:4) F400 (4p - 42°)	Inlet	69	76	82	84	88	86	84	78	93
HCFX 90 T4/T8 (A3:8) F400 (8p - 20°)	Inlet	53	65	75	75	77	72	72	62	82
HCFX 90 T4/T8 (A3:8) F400 (8p - 22°)	Inlet	53	64	73	74	76	72	72	62	81
HCFX 90 T4/T8 (A3:8) F400 (8p - 24°)	Inlet	53	63	71	73	75	72	72	62	80
HCFX 90 T4/T8 (A3:8) F400 (8p - 26°)	Inlet	53	62	69	72	74	72	72	63	79
HCFX 90 T4/T8 (A3:8) F400 (8p - 28°)	Inlet	54	60	67	71	73	72	71	63	79
HCFX 90 T4/T8 (A3:8) F400 (8p - 30°)	Inlet	52	59	65	70	72	72	71	63	78
HCFX 90 T4/T8 (A3:8) F400 (8p - 32°)	Inlet	51	58	64	69	71	72	70	62	77
HCFX 90 T4/T8 (A3:8) F400 (8p - 34°)	Inlet	51	58	63	68	71	71	69	61	76
HCFX 90 T4/T8 (A3:8) F400 (8p - 36°)	Inlet	51	58	64	67	71	71	69	61	76
HCFX 90 T4/T8 (A3:8) F400 (8p - 38°)	Inlet	53	60	65	68	71	71	69	61	77
HCFX 90 T4/T8 (A3:8) F400 (8p - 40°)	Inlet	54	62	67	68	72	71	68	62	77
HCFX 90 T4/T8 (A3:8) F400 (8p - 42°)	Inlet	55	62	67	69	73	72	69	62	78
HCFX 90 T4/T8 (A3:8) F400 (4p - 20°)	Inlet	69	81	90	91	93	88	88	78	98
HCFX 90 T4/T8 (A3:8) F400 (4p - 22°)	Inlet	69	80	88	90	92	88	88	78	97

Sound power Lw dB (A)										
Model		63 Hz	125 Hz	250 Hz	500 Hz	1000 Hz	2000 Hz	4000 Hz	8000 Hz	Total
HCFX 90 T4/T8 (A3:8) F400 (4p - 24°)	Inlet	69	79	86	89	91	88	88	78	96
HCFX 90 T4/T8 (A3:8) F400 (4p - 26°)	Inlet	69	77	84	88	90	88	87	79	95
HCFX 90 T4/T8 (A3:8) F400 (4p - 28°)	Inlet	69	76	82	87	89	88	87	79	94
HCFX 90 T4/T8 (A3:8) F400 (4p - 30°)	Inlet	68	75	80	86	88	88	87	79	94
HCFX 90 T4/T8 (A3:8) F400 (4p - 32°)	Inlet	67	74	80	85	87	88	86	78	93
HCFX 90 T4/T8 (A3:8) F400 (4p - 34°)	Inlet	66	74	79	84	86	87	85	77	92
HCFX 90 T4/T8 (A3:8) F400 (4p - 36°)	Inlet	67	74	80	83	86	87	85	77	92
HCFX 90 T4/T8 (A3:8) F400 (4p - 38°)	Inlet	69	76	81	83	87	87	84	77	92
HCFX 90 T4/T8 (A3:8) F400 (4p - 40°)	Inlet	70	77	83	84	88	87	84	77	93
HCFX 90 T4/T8 (A3:8) F400 (4p - 42°)	Inlet	70	78	83	84	88	88	85	78	93
HCFX 100 T4/T8 (A3:4) F400 (8p - 20°)	Inlet	50	60	66	72	76	76	77	74	82
HCFX 100 T4/T8 (A3:4) F400 (8p - 22°)	Inlet	50	60	66	72	76	76	77	74	82
HCFX 100 T4/T8 (A3:4) F400 (8p - 24°)	Inlet	51	60	66	72	75	76	77	73	82
HCFX 100 T4/T8 (A3:4) F400 (8p - 26°)	Inlet	51	59	65	71	74	75	77	72	82
HCFX 100 T4/T8 (A3:4) F400 (8p - 28°)	Inlet	51	59	65	71	74	75	77	71	81
HCFX 100 T4/T8 (A3:4) F400 (8p - 30°)	Inlet	52	59	65	70	74	75	77	70	81
HCFX 100 T4/T8 (A3:4) F400 (8p - 32°)	Inlet	52	58	65	70	73	74	76	70	80
HCFX 100 T4/T8 (A3:4) F400 (8p - 34°)	Inlet	53	57	65	69	72	74	76	69	80
HCFX 100 T4/T8 (A3:4) F400 (8p - 36°)	Inlet	53	57	65	70	72	74	75	69	80
HCFX 100 T4/T8 (A3:4) F400 (8p - 38°)	Inlet	52	58	65	70	73	74	76	69	80
HCFX 100 T4/T8 (A3:4) F400 (8p - 40°)	Inlet	52	59	66	71	75	75	76	70	81
HCFX 100 T4/T8 (A3:4) F400 (8p - 42°)	Inlet	53	61	67	72	76	76	77	71	82

Sound power Lw dB (A)										
Model		63 Hz	125 Hz	250 Hz	500 Hz	1000 Hz	2000 Hz	4000 Hz	8000 Hz	Total
HCFX 100 T4/T8 (A3:4) F400 (4p - 20°)	Inlet	66	76	81	88	91	92	93	90	98
HCFX 100 T4/T8 (A3:4) F400 (4p - 22°)	Inlet	66	76	82	88	91	92	93	90	98
HCFX 100 T4/T8 (A3:4) F400 (4p - 24°)	Inlet	67	76	81	87	91	92	93	89	98
HCFX 100 T4/T8 (A3:4) F400 (4p - 26°)	Inlet	67	75	81	87	90	91	93	88	97
HCFX 100 T4/T8 (A3:4) F400 (4p - 28°)	Inlet	67	75	81	86	90	91	93	87	97
HCFX 100 T4/T8 (A3:4) F400 (4p - 30°)	Inlet	68	74	81	86	90	91	93	86	97
HCFX 100 T4/T8 (A3:4) F400 (4p - 32°)	Inlet	68	74	81	86	89	90	92	86	96
HCFX 100 T4/T8 (A3:4) F400 (4p - 34°)	Inlet	69	73	81	85	88	90	91	85	96
HCFX 100 T4/T8 (A3:4) F400 (4p - 36°)	Inlet	69	73	81	86	88	90	91	85	96
HCFX 100 T4/T8 (A3:4) F400 (4p - 38°)	Inlet	68	74	81	86	89	90	92	85	96
HCFX 100 T4/T8 (A3:4) F400 (4p - 40°)	Inlet	68	75	81	87	90	91	92	86	97
HCFX 100 T4/T8 (A3:4) F400 (4p - 42°)	Inlet	69	77	83	88	92	92	93	87	98
HCFX 100 T4/T8 (A3:8) F400 (8p - 20°)	Inlet	56	65	76	86	84	83	84	79	91
HCFX 100 T4/T8 (A3:8) F400 (8p - 22°)	Inlet	56	64	75	84	83	82	83	78	90
HCFX 100 T4/T8 (A3:8) F400 (8p - 24°)	Inlet	56	64	73	81	82	81	82	77	88
HCFX 100 T4/T8 (A3:8) F400 (8p - 26°)	Inlet	56	63	72	79	80	80	81	76	87
HCFX 100 T4/T8 (A3:8) F400 (8p - 28°)	Inlet	56	63	71	77	80	80	80	75	86
HCFX 100 T4/T8 (A3:8) F400 (8p - 30°)	Inlet	56	63	70	75	79	79	80	74	85
HCFX 100 T4/T8 (A3:8) F400 (8p - 32°)	Inlet	55	63	68	74	77	78	79	73	84
HCFX 100 T4/T8 (A3:8) F400 (8p - 34°)	Inlet	55	62	67	72	76	77	78	72	83
HCFX 100 T4/T8 (A3:8) F400 (8p - 36°)	Inlet	54	61	66	71	75	77	78	72	83
HCFX 100 T4/T8 (A3:8) F400 (8p - 38°)	Inlet	55	62	67	72	76	78	78	72	83

Sound power Lw dB (A)										
Model		63 Hz	125 Hz	250 Hz	500 Hz	1000 Hz	2000 Hz	4000 Hz	8000 Hz	Total
HCFX 100 T4/T8 (A3:8) F400 (8p - 40°)	Inlet	56	63	68	73	76	78	79	73	84
HCFX 100 T4/T8 (A3:8) F400 (8p - 42°)	Inlet	56	63	68	73	77	78	79	73	84
HCFX 100 T4/T8 (A3:8) F400 (4p - 20°)	Inlet	72	81	92	102	100	99	100	95	107
HCFX 100 T4/T8 (A3:8) F400 (4p - 22°)	Inlet	72	80	91	100	99	98	99	94	106
HCFX 100 T4/T8 (A3:8) F400 (4p - 24°)	Inlet	72	79	89	97	97	97	98	93	104
HCFX 100 T4/T8 (A3:8) F400 (4p - 26°)	Inlet	72	79	88	95	96	96	97	92	103
HCFX 100 T4/T8 (A3:8) F400 (4p - 28°)	Inlet	72	79	87	93	96	95	96	91	102
HCFX 100 T4/T8 (A3:8) F400 (4p - 30°)	Inlet	72	79	86	91	95	95	96	90	101
HCFX 100 T4/T8 (A3:8) F400 (4p - 32°)	Inlet	71	79	84	90	93	94	95	89	100
HCFX 100 T4/T8 (A3:8) F400 (4p - 34°)	Inlet	71	78	83	88	92	93	94	88	99
HCFX 100 T4/T8 (A3:8) F400 (4p - 36°)	Inlet	70	77	82	87	91	93	94	87	99
HCFX 100 T4/T8 (A3:8) F400 (4p - 38°)	Inlet	71	78	83	88	92	94	94	88	99
HCFX 100 T4/T8 (A3:8) F400 (4p - 40°)	Inlet	71	79	84	89	92	94	95	89	100
HCFX 100 T4/T8 (A3:8) F400 (4p - 42°)	Inlet	72	79	84	89	93	94	95	89	100
HCFX 112 T4/T8 (A3:4) F400 (8p - 20°)	Inlet	50	62	67	74	78	78	80	76	85
HCFX 112 T4/T8 (A3:4) F400 (8p - 22°)	Inlet	52	63	68	74	78	79	81	76	86
HCFX 112 T4/T8 (A3:4) F400 (8p - 24°)	Inlet	53	62	67	74	77	78	80	75	85
HCFX 112 T4/T8 (A3:4) F400 (8p - 26°)	Inlet	54	62	67	73	77	78	79	74	84
HCFX 112 T4/T8 (A3:4) F400 (8p - 28°)	Inlet	55	62	67	73	76	77	79	73	83
HCFX 112 T4/T8 (A3:4) F400 (8p - 30°)	Inlet	55	62	67	72	76	77	78	72	83
HCFX 112 T4/T8 (A3:4) F400 (8p - 32°)	Inlet	55	61	67	72	75	76	78	71	82
HCFX 112 T4/T8 (A3:4) F400 (8p - 34°)	Inlet	54	60	66	71	74	76	77	70	82

Sound power Lw dB (A)										
Model		63 Hz	125 Hz	250 Hz	500 Hz	1000 Hz	2000 Hz	4000 Hz	8000 Hz	Total
HCFX 112 T4/T8 (A3:4) F400 (8p - 36°)	Inlet	55	60	67	71	74	76	77	70	82
HCFX 112 T4/T8 (A3:4) F400 (8p - 38°)	Inlet	55	61	67	72	75	76	78	71	82
HCFX 112 T4/T8 (A3:4) F400 (8p - 40°)	Inlet	56	63	68	73	76	77	78	71	83
HCFX 112 T4/T8 (A3:4) F400 (8p - 42°)	Inlet	57	63	69	73	76	78	78	72	83
HCFX 112 T4/T8 (A3:4) F400 (4p - 20°)	Inlet	66	78	83	90	94	94	96	92	101
HCFX 112 T4/T8 (A3:4) F400 (4p - 22°)	Inlet	68	79	84	90	94	95	96	92	102
HCFX 112 T4/T8 (A3:4) F400 (4p - 24°)	Inlet	69	78	83	90	93	94	96	91	101
HCFX 112 T4/T8 (A3:4) F400 (4p - 26°)	Inlet	70	78	83	89	93	94	95	90	100
HCFX 112 T4/T8 (A3:4) F400 (4p - 28°)	Inlet	71	78	83	89	92	93	95	89	99
HCFX 112 T4/T8 (A3:4) F400 (4p - 30°)	Inlet	71	78	83	88	92	93	94	88	99
HCFX 112 T4/T8 (A3:4) F400 (4p - 32°)	Inlet	70	77	82	88	91	92	94	87	98
HCFX 112 T4/T8 (A3:4) F400 (4p - 34°)	Inlet	70	76	82	87	90	92	93	86	98
HCFX 112 T4/T8 (A3:4) F400 (4p - 36°)	Inlet	71	76	83	87	90	92	93	86	98
HCFX 112 T4/T8 (A3:4) F400 (4p - 38°)	Inlet	71	77	83	88	91	92	93	87	98
HCFX 112 T4/T8 (A3:4) F400 (4p - 40°)	Inlet	72	79	84	89	91	93	94	87	99
HCFX 112 T4/T8 (A3:4) F400 (4p - 42°)	Inlet	72	79	84	89	92	94	94	88	99
HCFX 112 T4/T8 (A3:8) F400 (8p - 20°)	Inlet	57	66	76	85	85	87	87	81	93
HCFX 112 T4/T8 (A3:8) F400 (8p - 22°)	Inlet	57	65	75	83	84	86	86	80	91
HCFX 112 T4/T8 (A3:8) F400 (8p - 24°)	Inlet	57	65	74	81	83	85	85	79	90
HCFX 112 T4/T8 (A3:8) F400 (8p - 26°)	Inlet	58	65	73	80	83	84	84	78	90
HCFX 112 T4/T8 (A3:8) F400 (8p - 28°)	Inlet	58	65	72	78	82	83	83	78	89
HCFX 112 T4/T8 (A3:8) F400 (8p - 30°)	Inlet	58	65	72	77	81	83	83	77	88



Sound power Lw dB (A)										
Model		63 Hz	125 Hz	250 Hz	500 Hz	1000 Hz	2000 Hz	4000 Hz	8000 Hz	Total
HCFX 112 T4/T8 (A3:8) F400 (8p - 32°)	Inlet	58	65	70	76	80	81	81	75	87
HCFX 112 T4/T8 (A3:8) F400 (8p - 34°)	Inlet	57	64	69	74	78	80	80	73	85
HCFX 112 T4/T8 (A3:8) F400 (8p - 36°)	Inlet	57	64	69	74	77	79	80	73	85
HCFX 112 T4/T8 (A3:8) F400 (8p - 38°)	Inlet	57	64	69	74	78	80	80	73	85
HCFX 112 T4/T8 (A3:8) F400 (8p - 40°)	Inlet	58	65	70	74	78	80	80	74	86
HCFX 112 T4/T8 (A3:8) F400 (8p - 42°)	Inlet	58	65	70	75	78	80	79	73	85
HCFX 112 T4/T8 (A3:8) F400 (4p - 20°)	Inlet	73	82	92	101	101	103	103	97	109
HCFX 112 T4/T8 (A3:8) F400 (4p - 22°)	Inlet	73	81	91	99	100	102	102	96	107
HCFX 112 T4/T8 (A3:8) F400 (4p - 24°)	Inlet	73	81	90	97	99	101	101	95	106
HCFX 112 T4/T8 (A3:8) F400 (4p - 26°)	Inlet	74	81	89	96	98	100	100	94	106
HCFX 112 T4/T8 (A3:8) F400 (4p - 28°)	Inlet	74	81	88	94	98	99	99	94	105
HCFX 112 T4/T8 (A3:8) F400 (4p - 30°)	Inlet	74	80	87	93	97	99	99	93	104
HCFX 112 T4/T8 (A3:8) F400 (4p - 32°)	Inlet	74	81	86	91	96	97	97	91	103
HCFX 112 T4/T8 (A3:8) F400 (4p - 34°)	Inlet	73	80	85	90	94	96	96	89	101
HCFX 112 T4/T8 (A3:8) F400 (4p - 36°)	Inlet	73	80	85	90	93	95	95	89	101
HCFX 112 T4/T8 (A3:8) F400 (4p - 38°)	Inlet	73	80	85	90	94	96	95	89	101
HCFX 112 T4/T8 (A3:8) F400 (4p - 40°)	Inlet	74	81	86	90	94	96	95	90	102
HCFX 112 T4/T8 (A3:8) F400 (4p - 42°)	Inlet	73	80	85	91	94	96	95	89	101
HCFX 125 T4/T8 (A3:4) F400 (8p - 20°)	Inlet	56	69	74	82	86	86	88	85	93
HCFX 125 T4/T8 (A3:4) F400 (8p - 22°)	Inlet	59	70	75	82	86	87	89	85	93
HCFX 125 T4/T8 (A3:4) F400 (8p - 24°)	Inlet	59	69	74	80	84	85	87	82	91
HCFX 125 T4/T8 (A3:4) F400 (8p - 26°)	Inlet	60	68	73	78	82	83	85	80	90

Sound power Lw dB (A)										
Model		63 Hz	125 Hz	250 Hz	500 Hz	1000 Hz	2000 Hz	4000 Hz	8000 Hz	Total
HCFX 125 T4/T8 (A3:4) F400 (8p - 28°)	Inlet	60	67	72	77	80	82	83	77	88
HCFX 125 T4/T8 (A3:4) F400 (8p - 30°)	Inlet	58	65	70	75	79	80	81	75	86
HCFX 125 T4/T8 (A3:4) F400 (8p - 32°)	Inlet	58	65	70	75	78	80	81	74	86
HCFX 125 T4/T8 (A3:4) F400 (8p - 34°)	Inlet	58	65	70	74	77	79	80	72	85
HCFX 125 T4/T8 (A3:4) F400 (8p - 36°)	Inlet	58	65	70	74	77	79	80	72	85
HCFX 125 T4/T8 (A3:4) F400 (8p - 38°)	Inlet	58	65	70	75	77	79	80	73	85
HCFX 125 T4/T8 (A3:4) F400 (8p - 40°)	Inlet	59	66	71	75	78	80	80	73	86
HCFX 125 T4/T8 (A3:4) F400 (8p - 42°)	Inlet	59	66	71	76	79	81	80	74	86
HCFX 125 T4/T8 (A3:4) F400 (4p - 20°)	Inlet	72	85	90	98	102	102	104	101	109
HCFX 125 T4/T8 (A3:4) F400 (4p - 22°)	Inlet	75	86	91	98	102	103	105	101	109
HCFX 125 T4/T8 (A3:4) F400 (4p - 24°)	Inlet	75	85	90	96	100	101	103	98	107
HCFX 125 T4/T8 (A3:4) F400 (4p - 26°)	Inlet	76	84	89	94	98	99	101	96	106
HCFX 125 T4/T8 (A3:4) F400 (4p - 28°)	Inlet	75	82	87	93	96	98	99	93	104
HCFX 125 T4/T8 (A3:4) F400 (4p - 30°)	Inlet	74	81	86	91	95	96	97	91	102
HCFX 125 T4/T8 (A3:4) F400 (4p - 32°)	Inlet	74	81	86	90	94	96	96	90	102
HCFX 125 T4/T8 (A3:4) F400 (4p - 34°)	Inlet	73	80	85	90	93	95	96	88	101
HCFX 125 T4/T8 (A3:4) F400 (4p - 36°)	Inlet	74	81	86	90	93	95	96	88	101
HCFX 125 T4/T8 (A3:4) F400 (4p - 38°)	Inlet	74	81	86	91	93	95	96	89	101
HCFX 125 T4/T8 (A3:4) F400 (4p - 40°)	Inlet	75	82	87	91	93	96	96	89	102
HCFX 125 T4/T8 (A3:4) F400 (4p - 42°)	Inlet	75	82	87	92	94	96	96	90	102
HCFX 125 T4/T8 (A3:8) F400 (8p - 20°)	Inlet	62	71	78	87	92	95	94	89	99
HCFX 125 T4/T8 (A3:8) F400 (8p - 22°)	Inlet	63	70	77	86	91	94	93	88	98

Sound power Lw dB (A)										
Model		63 Hz	125 Hz	250 Hz	500 Hz	1000 Hz	2000 Hz	4000 Hz	8000 Hz	Total
HCFX 125 T4/T8 (A3:8) F400 (8p - 24°)	Inlet	62	70	76	84	90	92	92	86	97
HCFX 125 T4/T8 (A3:8) F400 (8p - 26°)	Inlet	62	69	75	82	88	90	90	84	95
HCFX 125 T4/T8 (A3:8) F400 (8p - 28°)	Inlet	62	68	75	81	86	89	89	82	94
HCFX 125 T4/T8 (A3:8) F400 (8p - 30°)	Inlet	62	67	74	80	85	87	88	81	92
HCFX 125 T4/T8 (A3:8) F400 (8p - 32°)	Inlet	61	67	73	79	83	86	86	79	91
HCFX 125 T4/T8 (A3:8) F400 (8p - 34°)	Inlet	61	68	73	78	81	84	84	76	89
HCFX 125 T4/T8 (A3:8) F400 (8p - 36°)	Inlet	61	68	73	77	81	83	82	75	88
HCFX 125 T4/T8 (A3:8) F400 (8p - 38°)	Inlet	60	67	72	77	80	82	82	75	88
HCFX 125 T4/T8 (A3:8) F400 (8p - 40°)	Inlet	60	67	72	77	80	82	81	74	87
HCFX 125 T4/T8 (A3:8) F400 (8p - 42°)	Inlet	60	67	72	77	80	82	80	74	87
HCFX 125 T4/T8 (A3:8) F400 (4p - 20°)	Inlet	78	86	93	103	108	111	110	105	115
HCFX 125 T4/T8 (A3:8) F400 (4p - 22°)	Inlet	79	86	93	102	107	110	109	104	114
HCFX 125 T4/T8 (A3:8) F400 (4p - 24°)	Inlet	78	85	92	100	106	108	108	102	113
HCFX 125 T4/T8 (A3:8) F400 (4p - 26°)	Inlet	78	85	91	98	104	106	106	100	111
HCFX 125 T4/T8 (A3:8) F400 (4p - 28°)	Inlet	78	84	91	97	102	105	105	98	110
HCFX 125 T4/T8 (A3:8) F400 (4p - 30°)	Inlet	77	83	90	96	101	103	104	97	108
HCFX 125 T4/T8 (A3:8) F400 (4p - 32°)	Inlet	77	83	89	95	99	102	102	94	107
HCFX 125 T4/T8 (A3:8) F400 (4p - 34°)	Inlet	77	83	89	94	97	99	100	92	105
HCFX 125 T4/T8 (A3:8) F400 (4p - 36°)	Inlet	77	83	89	93	96	98	98	91	104
HCFX 125 T4/T8 (A3:8) F400 (4p - 38°)	Inlet	76	83	88	93	96	98	97	91	104
HCFX 125 T4/T8 (A3:8) F400 (4p - 40°)	Inlet	76	83	88	93	96	98	97	90	103
HCFX 125 T4/T8 (A3:8) F400 (4p - 42°)	Inlet	76	83	88	93	96	98	96	90	103