

AATVA

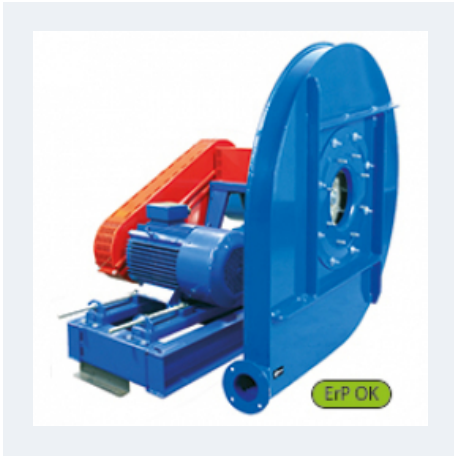

HIGH PRESSURE WITH BACKWARD IMPELLER AND BELT TRASMISSION

MANUFACTURING FEATURES:

- Fan made of Fe360 sheet. The fan paint finish is based on a Qualicoat polyester powder coating stoved at 200°C, with an average film thickness of 70 microns. Average heat resistance of coating is 180°C with peaks of 200°C.
- Fully welded housing.
- High efficiency simple inlet backward impeller with self-cleaning system made of Fe360 sheet statically and dynamically balanced. Impellers are painted with polyester primer that resists temperatures up to 300°C.
- Motorized fan with base frame (configuration 12). Full equipped fans including: motor, pulleys, belts, belts guard and shaft guard. Fitted over a base plate.
- Standard orientation LG270
- It allows adjusting the orientation locally from models 250 to 630. Models sizes from 710 to 1000 size the orientation is fixed.

APPLICATIONS:

- Designed for inline installation, they are suitable for:
- Industrial applications, extraction or injection of air.
 - Cooling of machines and parts.
 - Exhaust after filters, separators and cyclones.
 - Pneumatic transport.
 - Clean air transport.
 - Maximum working temperature: carried air: 200°C, ambient: 60°C.

UNDER REQUEST

- Fans for 60Hz and special voltages.
- 2 speed motor.
- Fan with free shaft (configuration 1) or with motor supported on the pedestal side (configuration 9).
- C4 or C5 coating painting
- Hot dip galvanized
- Special steel (Cor-Ten A, Hardox...)
- Inox 304 (normal or electropolished finish)
- Inox 316 (normal or electropolished finish)
- Cooling wheel
- Anticaloric paint
- Reinforced housing
- Fully welded housing (waterproof)
- Insulated housing
- Split casing (for big sizes)
- Inspection door to facilitate maintenance and cleaning
- Drain plug.
- Airtight axle
- Frontal foot
- Double suction flange
- Available in non-sparking air passage and standard motor.
- Other brands of motors.
- Orientation: RD0, RD45, RD90, RD135, RD180, RD225, RD270, RD315, LG0, LG45, LG90, LG135, LG180. LG225, LG315.

Accessories



Technical data

Three-phase motor

Code	Model	RPM	Min. Rated power kW	Max. Rated power kW	Max. Airflow m ³ /h	Sound db (A)**	Weight t*	Connect. diagram
5070035__R__	AATVA 350/P	2000 - 3500	0,37	1,10	240	54	28	1
5070040__R__	AATVA 400/P	2000 - 3500	0,37	1,50	350	57	35	1
5070045__R__	AATVA 450/P	2000 - 3500	0,37	3	370	59	38	1
5070050__R__	AATVA 500/P	1800 - 3500	0,37	3	350	60	42	1
5070056__R__	AATVA 560/P	1800 - 3500	0,37	3	370	64	65	1
5070063__R__	AATVA 630/P	1600 - 3500	0,37	5,50	530	67	70	1
5070071__R__	AATVA 710/P	1400 - 3500	0,55	7,50	760	69	100	1
5070080__R__	AATVA 800/P	1450 - 3500 (turb. Clase II)	0,75	11	1.040	73	125	1
5070090__R__	AATVA 900/P	1250 - 3200 (turb. Clase II)	3	18,50	1.410	74	220	1
5070100__R__	AATVA 1000/P	1250 - 2950	4	22	1.770	75	330	1

Notes:

* The motor is not included in fan weight

** Total sound pressure level at the point of maximum flow measured in dB(A) in the suction measured in free field at a distance of 6m from the source

Dimensions

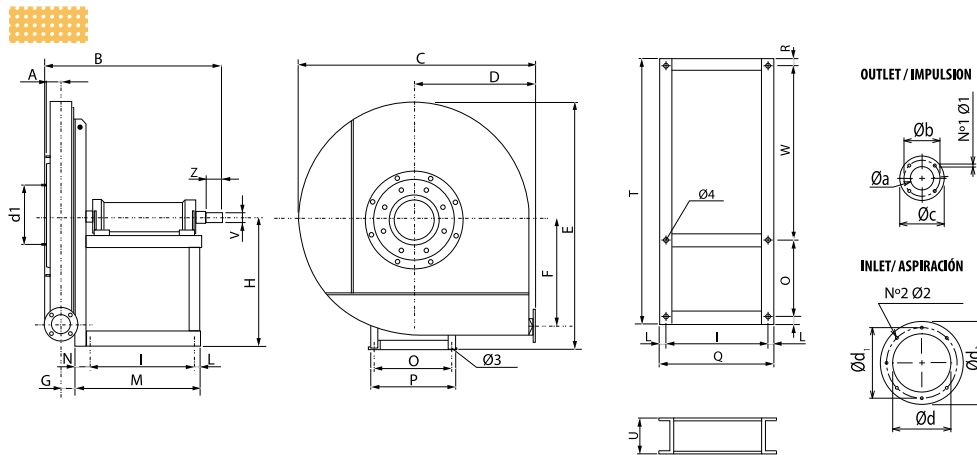

Model	A	B	C	D	E	F	G	H	I
AATVA 350/P	34	400	515	270	520	220	30	280	210
AATVA 400/P	34	405	675	350	673	300	31	355	210
AATVA 450/P	34	405	675	350	673	300	31	355	210
AATVA 500/P	34	405	675	350	673	300	31	355	210
AATVA 560/P	34	485	780	405	800	355	32	425	284
AATVA 630/P	34	485	780	405	800	355	32	425	284
AATVA 710/P	40	650	880	455	900	400	38	475	407
AATVA 800/P	40	650	980	505	1010	450	38	530	407
AATVA 900/P	49	695	1120	570	1140	500	48	600	407
AATVA 1000/P	49	850	1248	635	1305	560	50	670	477

Model	L	M	N	N1xØ1	N2xØ2	O	P	Q	R
AATVA 350/P	17	282	55	4x8,5	Nº8 M6x20	228	255	244	13,5
AATVA 400/P	17	282	55	4x8,5	Nº8 M6x20	228	255	244	13,5
AATVA 450/P	17	282	55	4x8,5	Nº8 M6x20	228	255	244	13,5
AATVA 500/P	17	282	55	4x8,5	Nº8 M6x20	228	255	244	13,5
AATVA 560/P	23	347	40	4x8,5	Nº8 M6x20	288	324	330	18
AATVA 630/P	23	347	40	4x8,5	Nº8 M6x20	288	324	303	18
AATVA 710/P	28	485	50	4x8,5	Nº8 M6x20	355	400	463	22,5

Model	L	M	N	N1xØ1	N2xØ2	O	P	Q	R
AATVA 800/P	28	485	50	4x8,5	Nº8 M6x20	355	400	463	22,5
AATVA 900/P	28	485	50	4x8,5	Nº8 M6x20	355	400	463	22,5
AATVA 1000/P	22,5	544,5	45	4x8,5	Nº8 M6x20	485	530	543	22,5

Model	S	T	U	V	Z	a	b	c	d
AATVA 350/P	445	700	80	19	40	54	84	104	145
AATVA 400/P	445	700	80	19	40	54	84	104	145
AATVA 450/P	445	700	80	19	40	54	84	104	145
AATVA 500/P	445	700	80	19	40	54	84	104	145
AATVA 560/P	576	900	100	24	50	54	84	104	145
AATVA 630/P	576	900	100	24	50	54	84	104	145
AATVA 710/P	660	1060	120	28	60	66	102	126	165
AATVA 800/P	660	1060	120	28	60	66	102	126	165
AATVA 900/P	780	1180	120	38	80	83	118	143	185
AATVA 1000/P	780	1310	120	42	110	83	118	143	185

Model	d1	d2	Ø3	Ø4
AATVA 350/P	182	215	10	12
AATVA 400/P	182	215	12	12
AATVA 450/P	182	215	12	12
AATVA 500/P	182	215	14	12
AATVA 560/P	182	215	14	15
AATVA 630/P	182	215	14	15
AATVA 710/P	200	235	14	15
AATVA 800/P	200	235	14	15
AATVA 900/P	219	250	14	15
AATVA 1000/P	219	250	14	15

Wiring diagram

DIAGRAM N° 1

230/400V

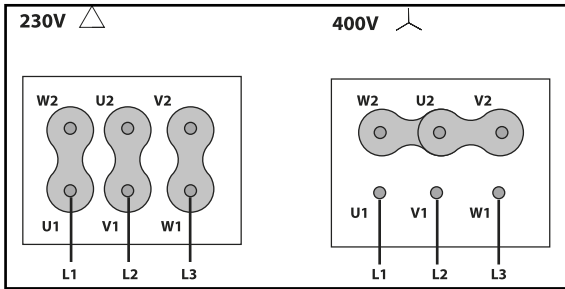

400/690V

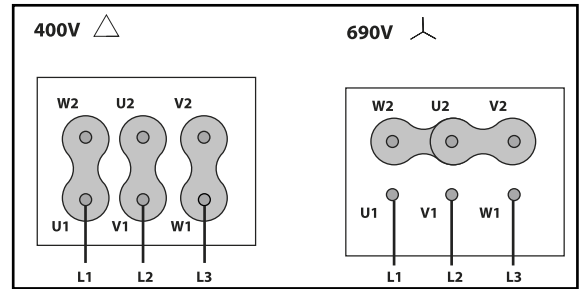

CHARACTERISTIC CURVE

AATVA 350/P

AIR FLOW - PRESSURE

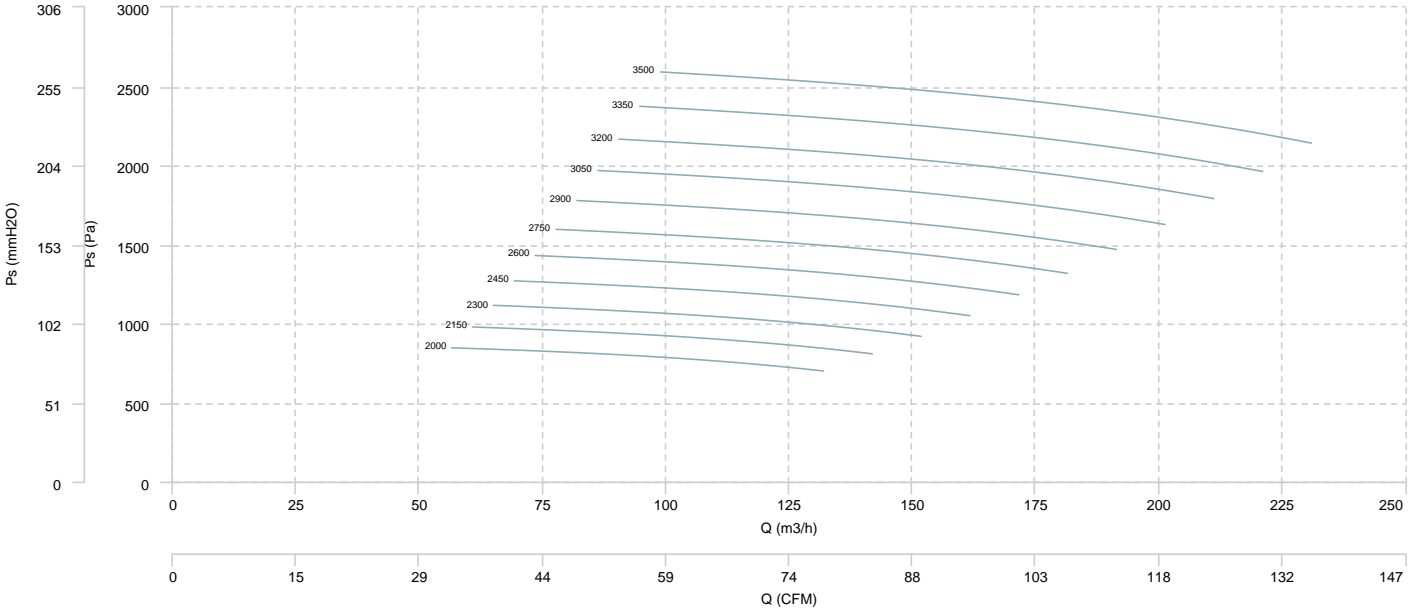

AIR FLOW - MECHANICAL POWER

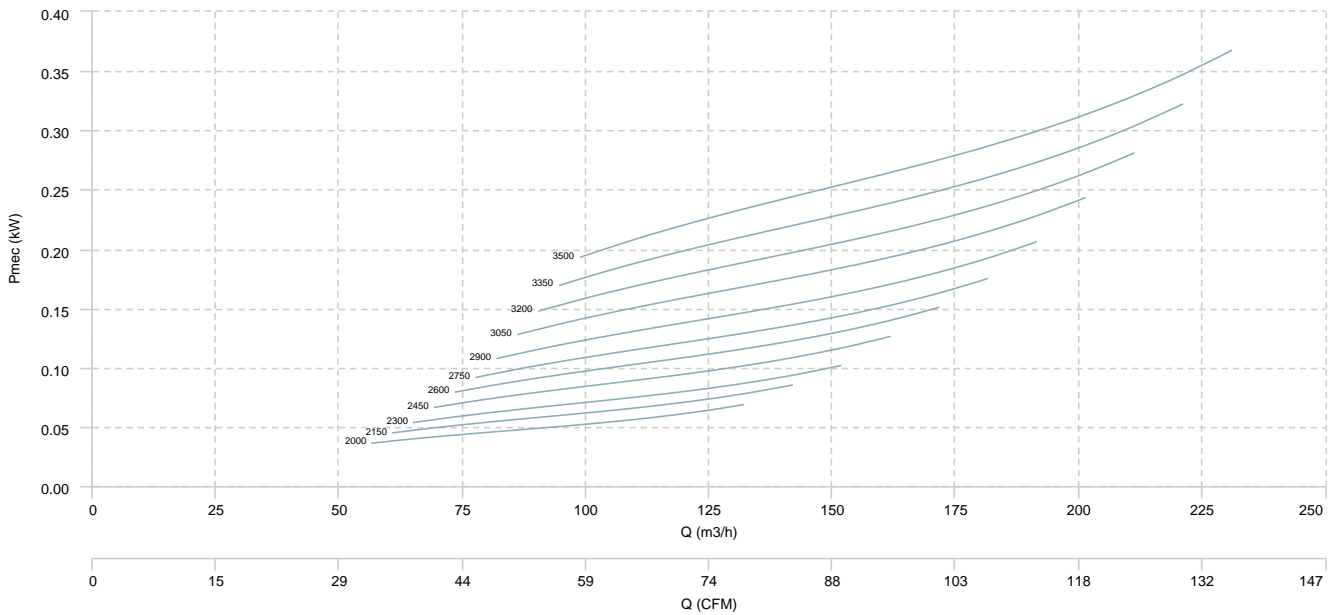

AATVA 400/P

AIR FLOW - PRESSURE

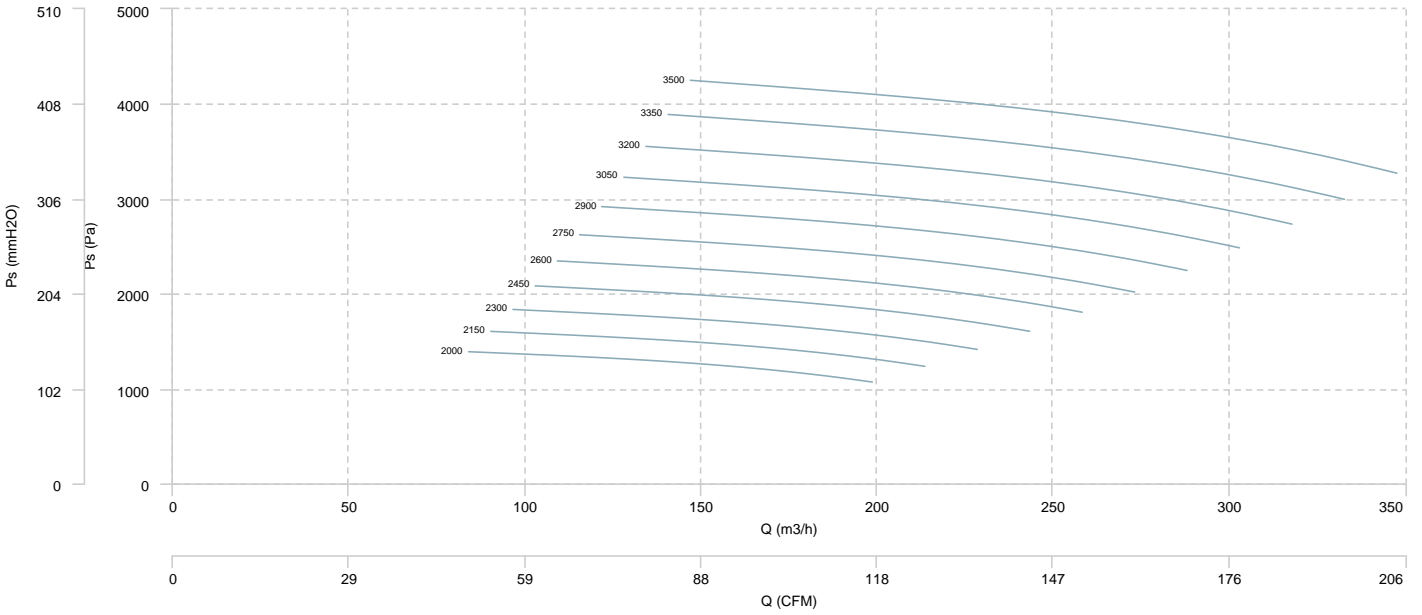

AIR FLOW - MECHANICAL POWER

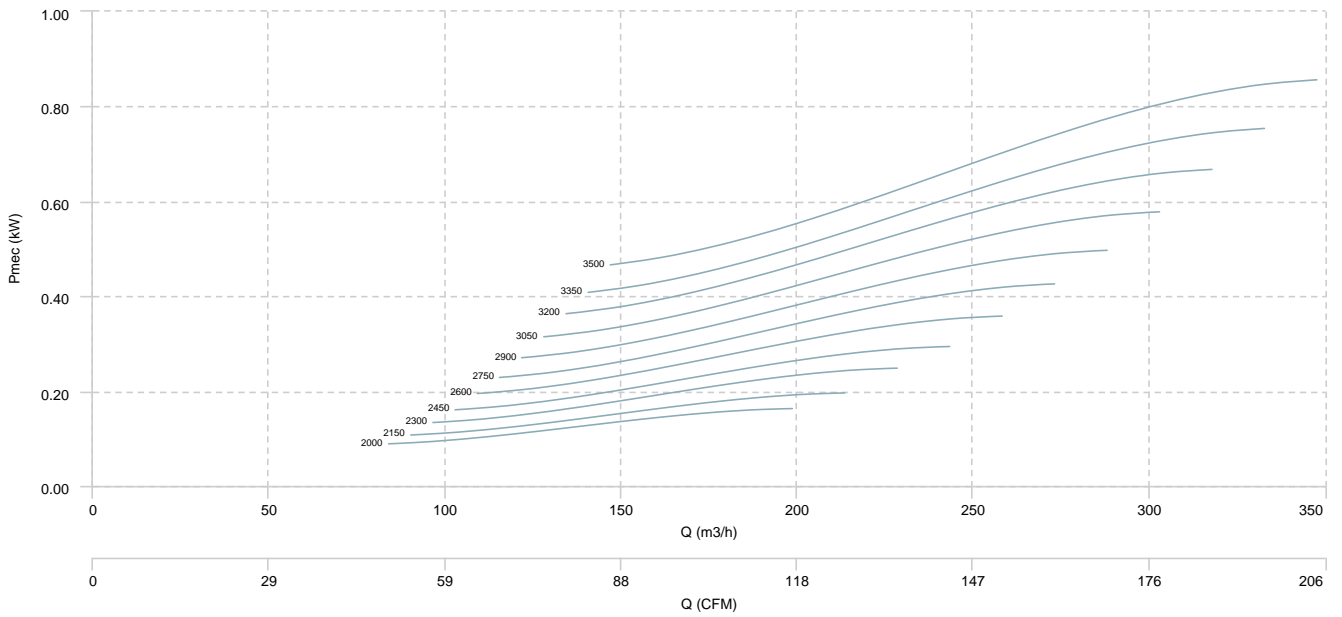

AATVA 450/P

AIR FLOW - PRESSURE

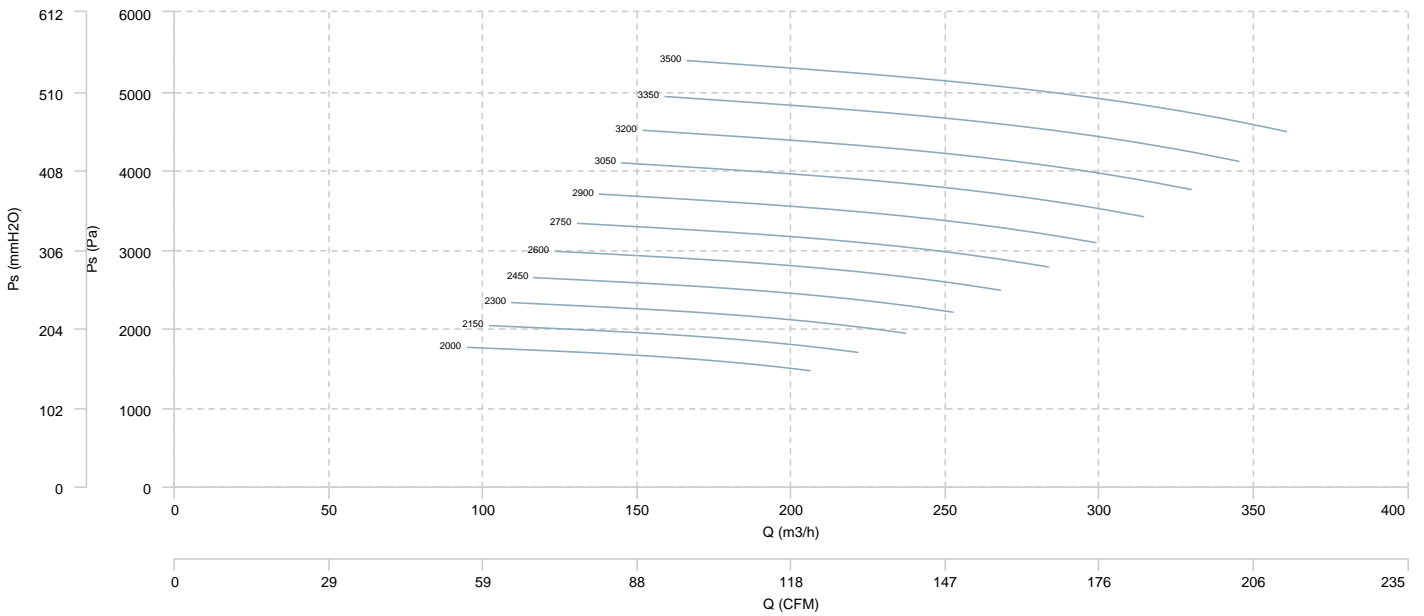

AIR FLOW - MECHANICAL POWER

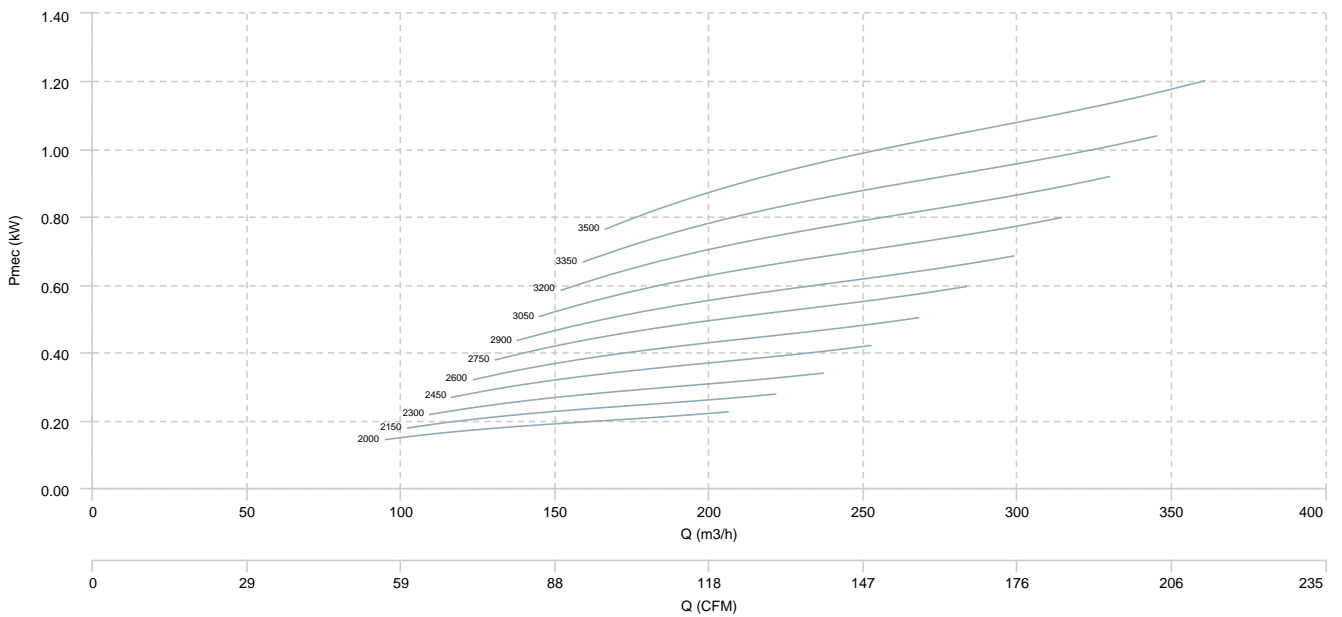

AATVA 500/P

AIR FLOW - PRESSURE

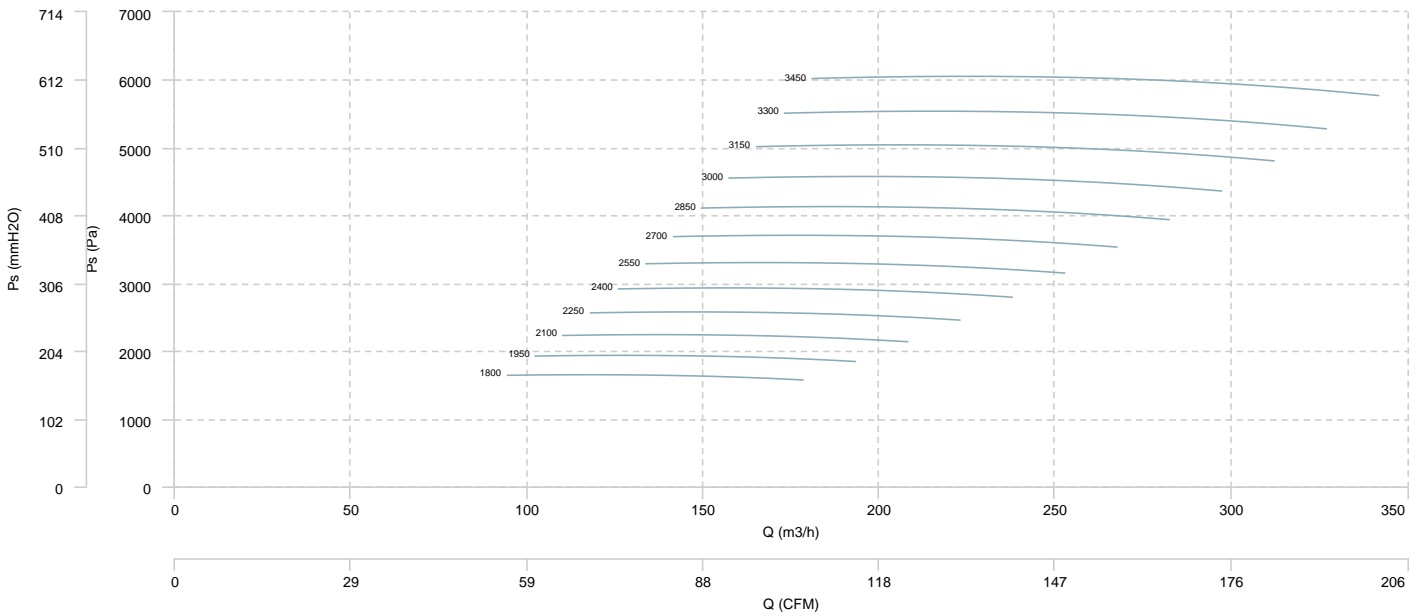

AIR FLOW - MECHANICAL POWER

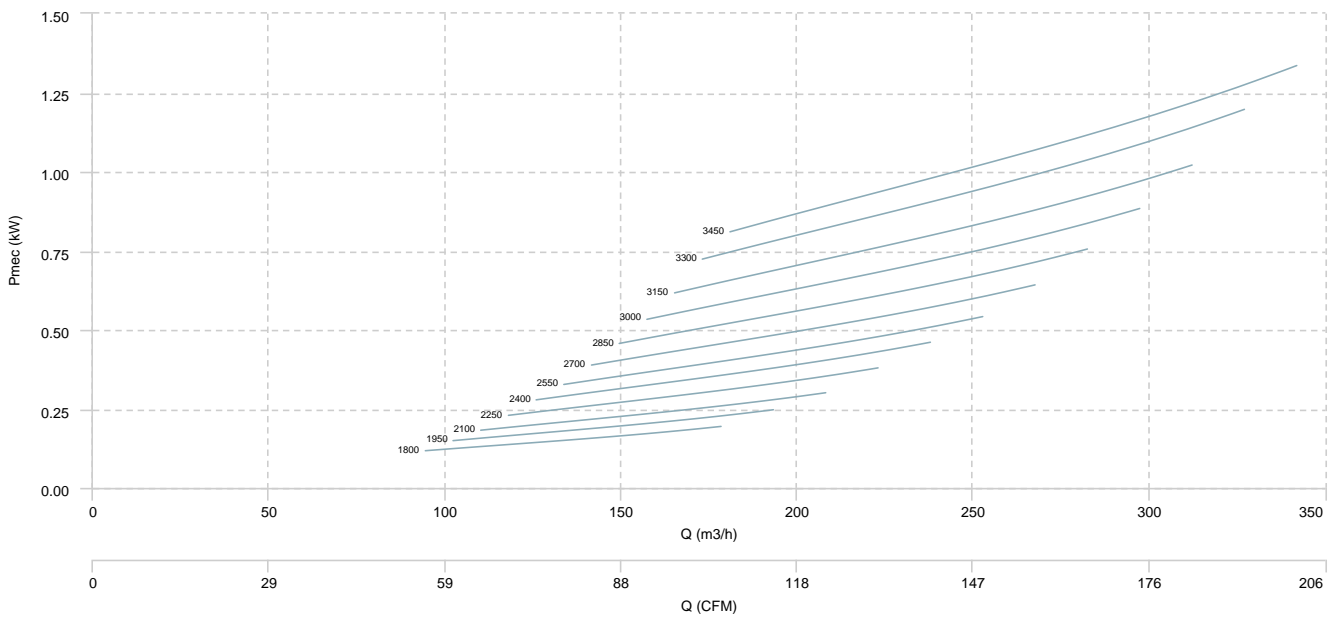

AATVA 560/P

AIR FLOW - PRESSURE

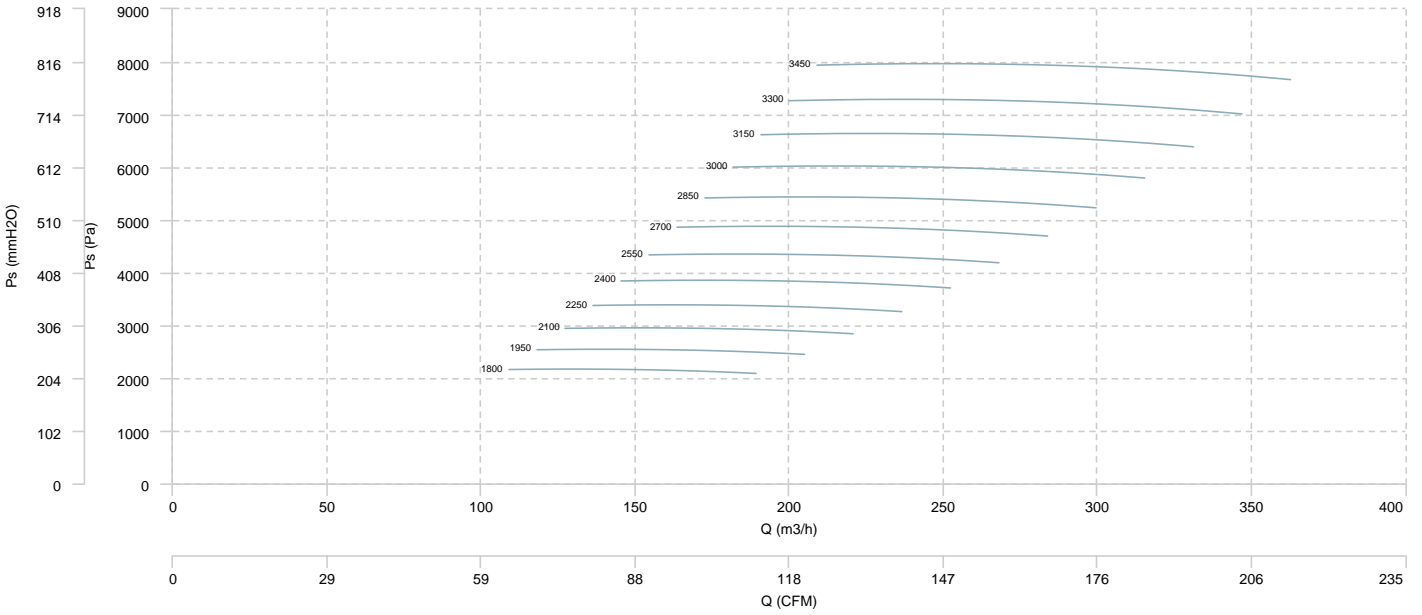

AIR FLOW - MECHANICAL POWER

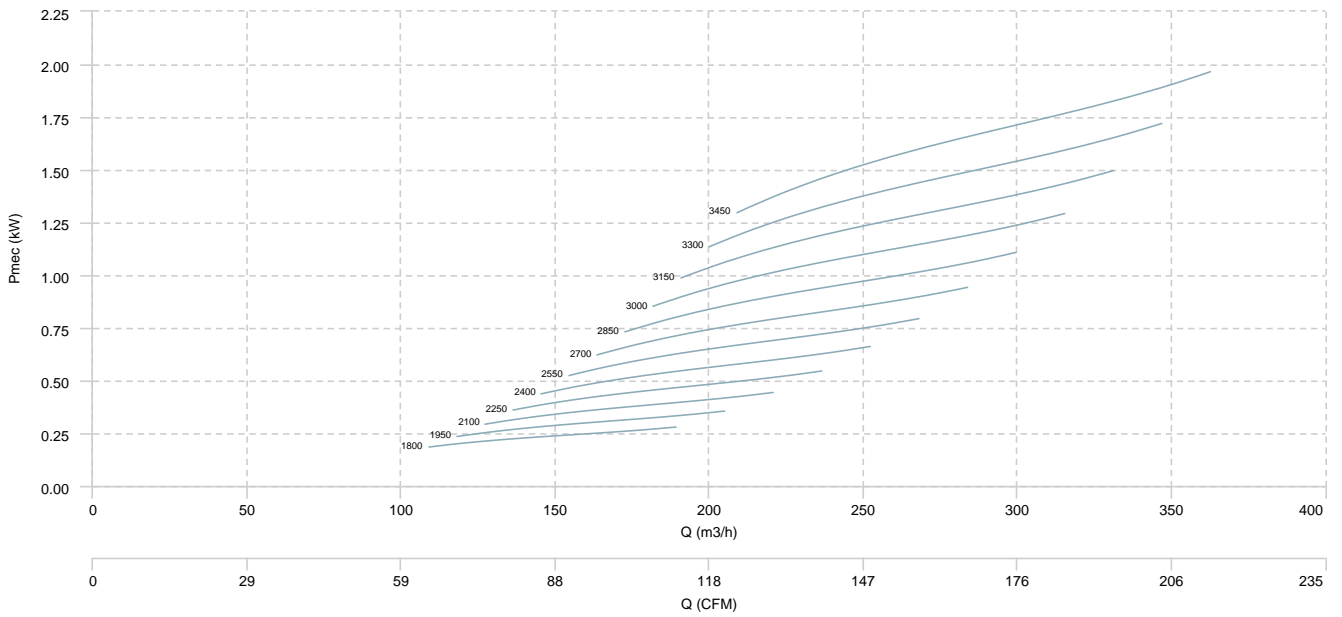

AATVA 630/P

AIR FLOW - PRESSURE

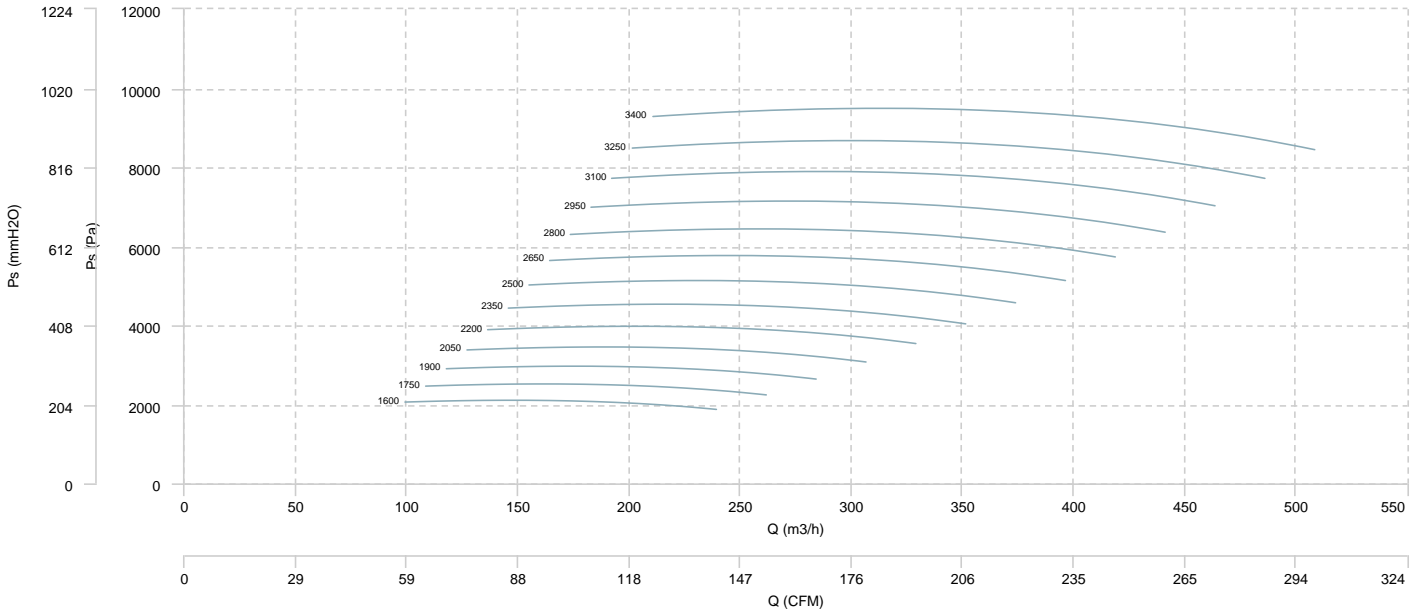

AIR FLOW - MECHANICAL POWER

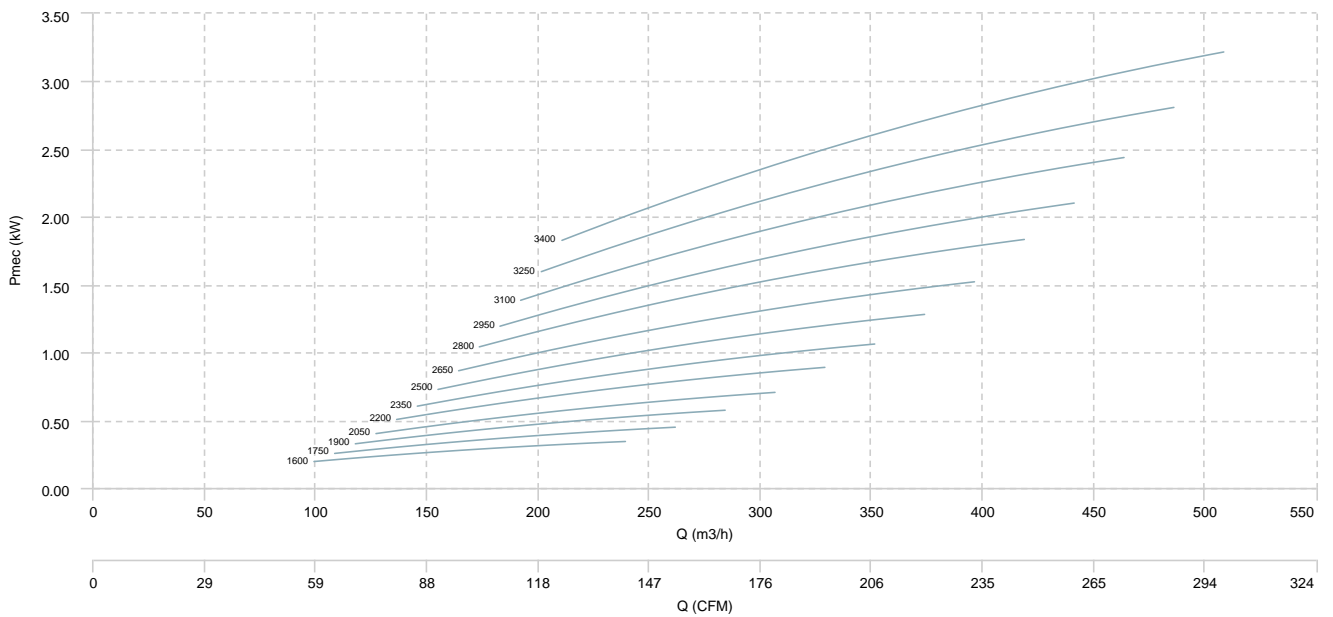

AATVA 710/P

AIR FLOW - PRESSURE

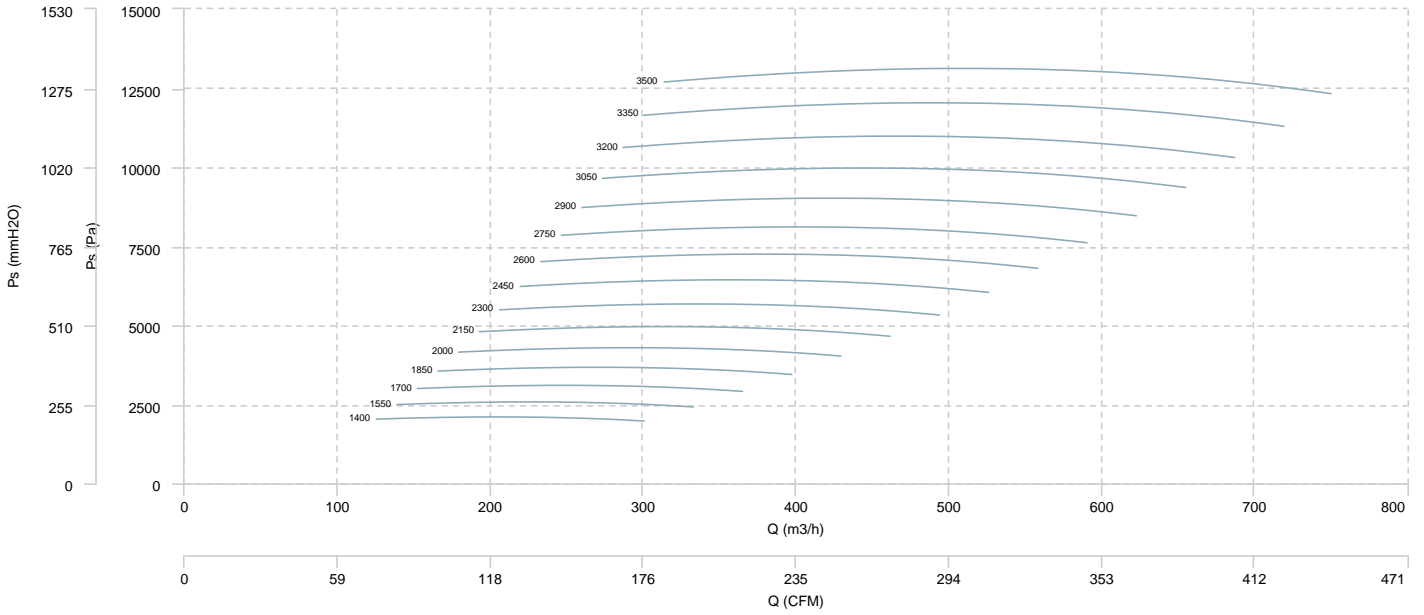

AIR FLOW - MECHANICAL POWER

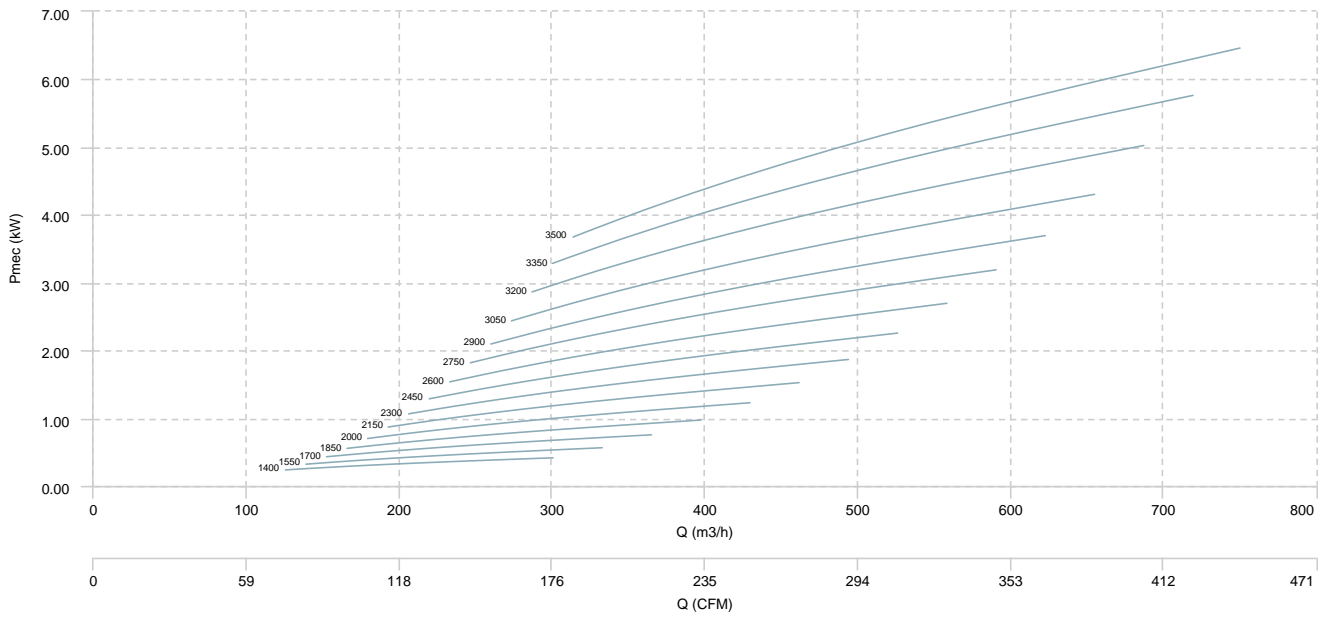

AATVA 800/P

AIR FLOW - PRESSURE

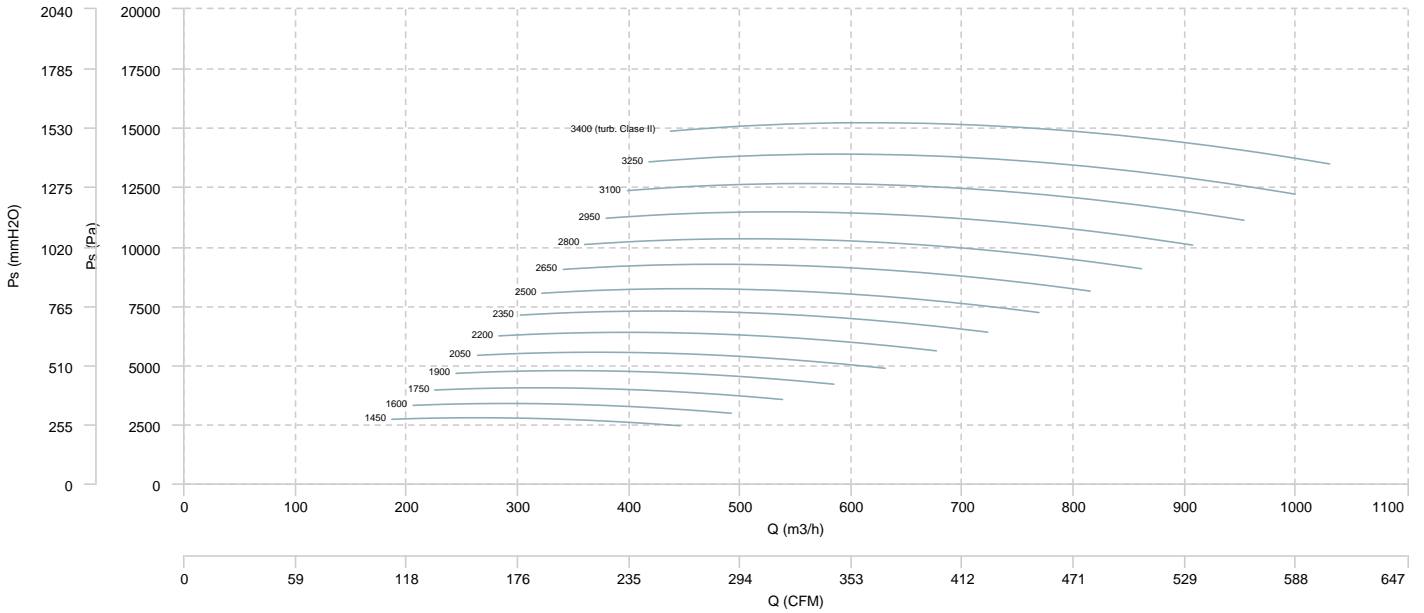

AIR FLOW - MECHANICAL POWER

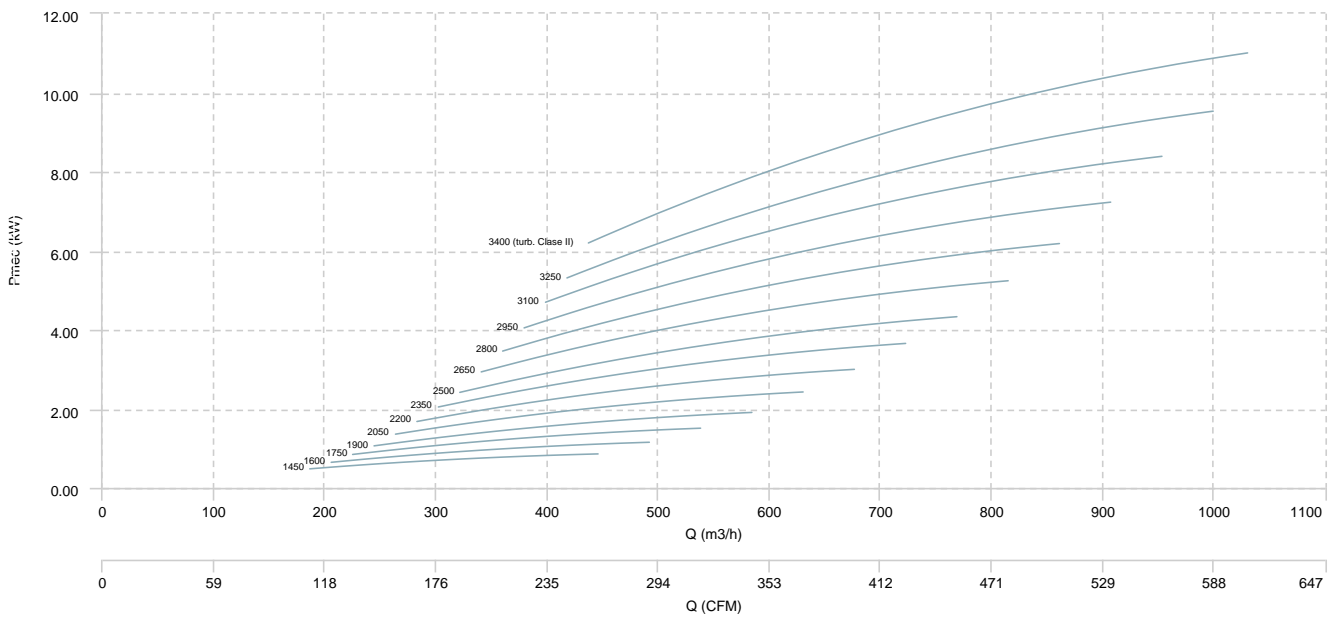

AATVA 900/P

AIR FLOW - PRESSURE

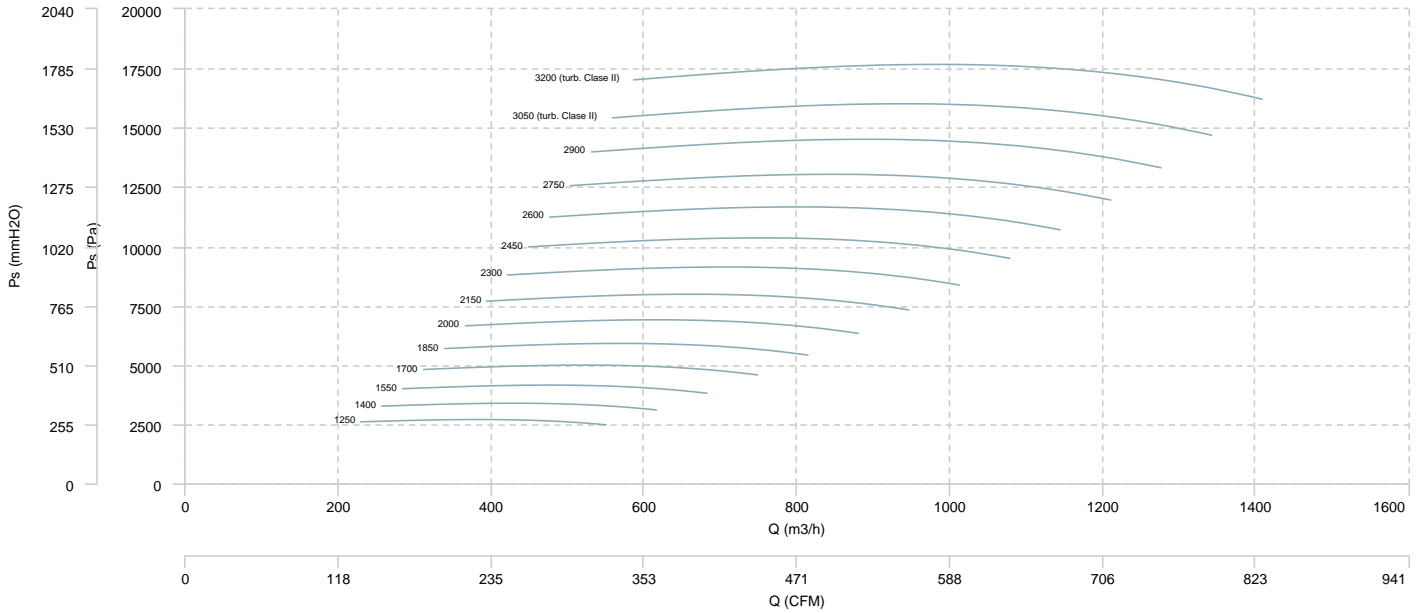

AIR FLOW - MECHANICAL POWER

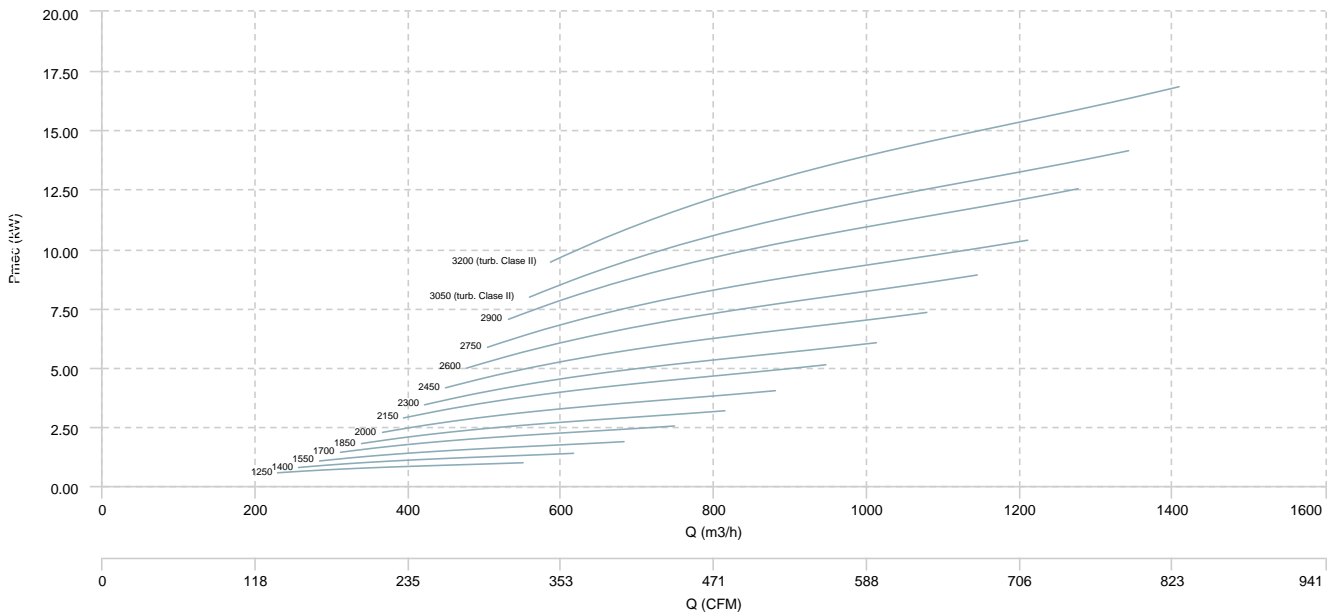

AATVA 1000/P

AIR FLOW - PRESSURE

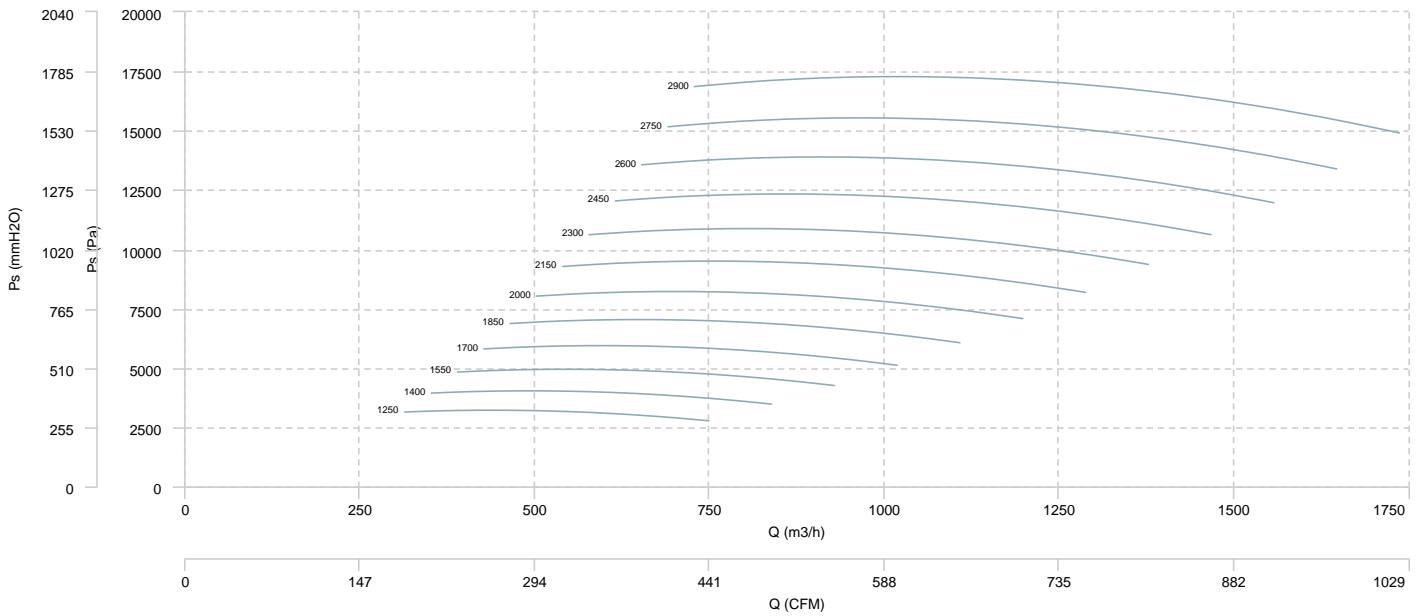

AIR FLOW - MECHANICAL POWER

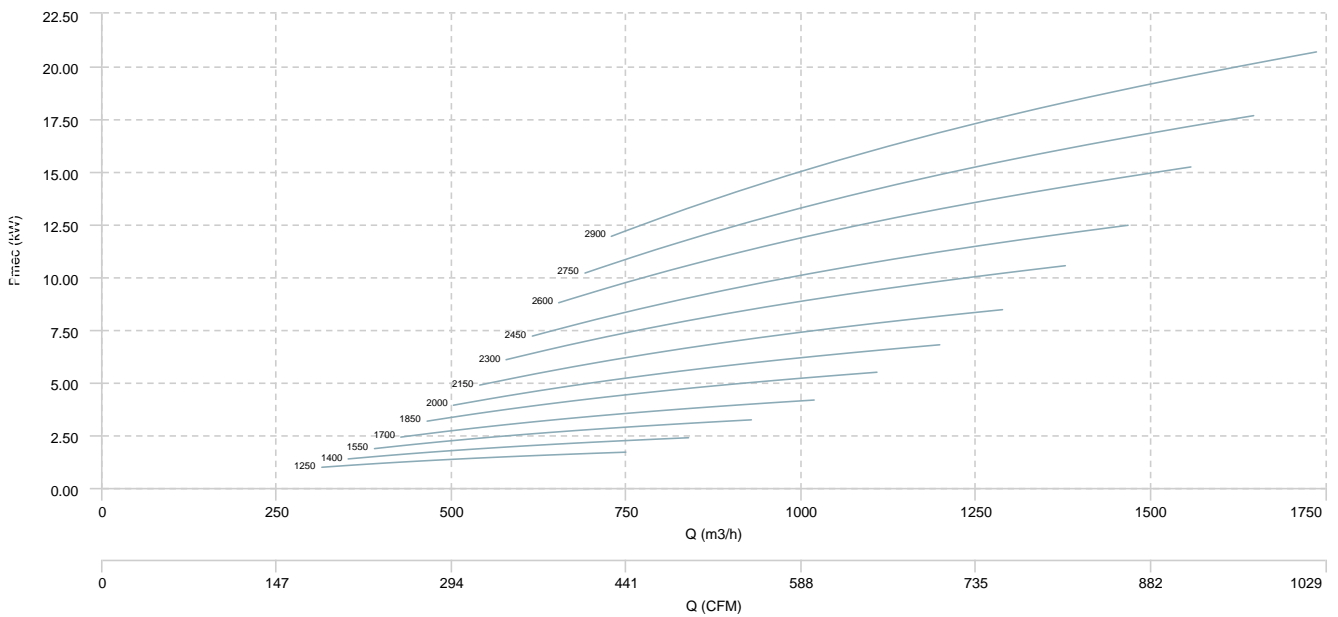

Sound data

Sound power Lw dB (A)										
Model		63 Hz	125 Hz	250 Hz	500 Hz	1000 Hz	2000 Hz	4000 Hz	8000 Hz	Total
AATVA 350/P (2000 RPM)	Inlet	40	52	58	63	63	59	52	49	68
AATVA 400/P (2000 RPM)	Inlet	43	55	62	66	67	62	56	53	71
AATVA 450/P (2000 RPM)	Inlet	46	58	64	68	69	64	58	55	73
AATVA 500/P (1800 RPM)	Inlet	44	56	62	66	67	62	56	53	71
AATVA 560/P (1800 RPM)	Inlet	48	60	66	71	71	67	60	57	76
AATVA 630/P (1600 RPM)	Inlet	48	60	67	71	72	67	61	58	76
AATVA 710/P (1400 RPM)	Inlet	49	61	67	71	72	67	61	58	76
AATVA 800/P (1450 RPM)	Inlet	52	64	71	75	76	71	65	62	80
AATVA 900/P (1250 RPM)	Inlet	52	64	70	74	75	71	64	61	80
AATVA 1000/P (1250 RPM)	Inlet	55	67	73	77	78	73	67	64	82

Notes:

* To calculate the sound power level at different rpm from those indicated above, use the following formula:

$$Lw\ dB(A)_{rpmA} = Lw\ dB(A)_{rpmB} + 52.5 \cdot \log_{10} \frac{rpmA}{rpmB}$$