



BLAUBERG
Motoren



CENTRIFUGAL FANS

CATALOGUE 2022

FAN MOTORS

THE MOTORS ARE POWERED BY DIRECT OR ALTERNATING CURRENT.

- A direct current motor is powered by a direct power supply.
- An alternating current motor is powered by an alternating power supply.

Alternating current motors are the most widely used motors because the basic electric grid in the country has alternating power supply.

ALTERNATING CURRENT MOTORS HAVE TWO TYPES:

- **Synchronous** electric motors are alternating current motors with a rotor that rotates synchronously with a magnetic field.
- **Asynchronous** electric motors are alternating current motors with the magnetic field frequency exceeding the motor rotation speed.

Asynchronous motors

Nowadays the asynchronous electric motors find wide application.

Asynchronous electric motors consist of two basic components, the stator and the rotor.

The stator is a fixed motor component. On the inner side the stator has some slots for laying of three-phase cable winding that is powered by three-phase current. The rotor is a rotating part of the motor and also has slots for inserting the cable winding. The rotor and the stator are assembled of separate 0.35-0.5 mm thick electrotechnical steel pressed plates.

Separate plates are insulated from each other with a varnish layer. The air gap between the stator and the rotor is kept as low as possible: 0.3-0.35 mm for low capacity machinery and 1.0-1.5 for more powerful machinery.

Depending on the rotor design the asynchronous motors are available in short circuit modification and phased modifications. Short circuit motors are the most widely used motors because of their simple design and easy operation. The three-phase stator winding is inserted inside the slots and consists of a number of interconnected coils. Each coil consists of one or several turns which are insulated against each other and against the slot walls.

THE ASYNCHRONOUS ELECTRIC MOTOR WITH SHORT CIRCUIT ROTOR HAS THE FOLLOWING ADVANTAGES:

- Permanent speed at various loads.
- Resistance to short-term mechanical overloads.
- Easy structure.
- Easy start-up.
- Higher $\cos \varnothing$ and efficiency compared to electric motors with phased rotor.

The design of the asynchronous electric motor with external rotor is similar to that of the standard asynchronous electric motor.

The only difference is the position of the rotor. The electric rotor motor is located inside the stator winding and the stator with turns is located in the electric motor center. This configuration provides a compact size of the ventilation unit. The electric motor shaft is carried by ball bearings fixed inside the stator and the impeller is fixed in the rotor casing. Such a design provides air cooling of the electric motor which makes it applicable for a wide temperature range. The electric motors are assembled with the impellers and are subjected to static and dynamic balancing in compliance with DIN ISO 1940. The motors have an integrated overheating protection with automatic restart.

All the motors have 100 % controllable speed range. Speed control is performed with a transformer or electronic devices. Explosionproof motors are controlled exclusively by transformers within 25 % up to 100 % of the rated voltage range. Speed control is performed by voltage change whereas the frequency in the grid remains the same. The electric motor speed is smoothly decreased as power voltage drops or is increased as power voltage rises. The motor can also be controlled with a frequency converter.

ADVANTAGES OF THE ASYNCHRONOUS ELECTRIC MOTOR WITH EXTERNAL ROTOR:

- Long service life.
- Light weight and small overall dimensions.
- Easy assembly and installation.
- Aligned impeller and electric motor.
- Regulated air capacity.
- Low energy demand during start-up.



EC motors

The electric motor with electronic commutation (EC motor) is a high-efficient synchronous direct current motor driven by an electronic commutating unit (controller). It has no friction and wearing parts as a collector or brushes, unlike the standard motor. The function of these parts is performed with the maintenance-free electronic circuit of the EC controller.

The EC technology is the state-of-the-art method for arrangement of energy saving and high efficient ventilation.

The energy demand of EC motors is by 50 % less as compared to standard motors and efficiency reaches 90 %.

These new electric motors are featured with high performance, low noise level and controllable total speed range. The electronic EC controller enables some other smart functions, e.g. fan control according to measured temperature, pressure and other parameters.

A unique software ensures high control accuracy for fans integrated into a single network. Parameters of a single fan integrated into a common network may be centrally corrected to match the ventilation system parameters. All the system parameters are displayed online on a computer. This enables programming individual operation modes of each fan in the system. This technology also enables programming custommade settings to meet individual customer requirements.



ADVANTAGES OF EC MOTORS:

- Efficient performance at any rotation speed of the fan, including very low speed.
- Low heat emission.
- Small overall dimensions of the unit due to external rotor design.
- Maximum fan rotation speed does not depend on frequency in the grid.
- The fan is suitable for connection both to 50 Hz and 60 Hz power mains.
- High efficiency at low rotation speed.
- Energy demand is by 1/3 less as compared to standard motors.
- Data interchange between PC and fan for parameter setting and control.
- Integration of all fans into a unified system and their centralized control.

DESIGNATION KEY

AC fans

BL-B 190 A-2 E-A 0 1-01

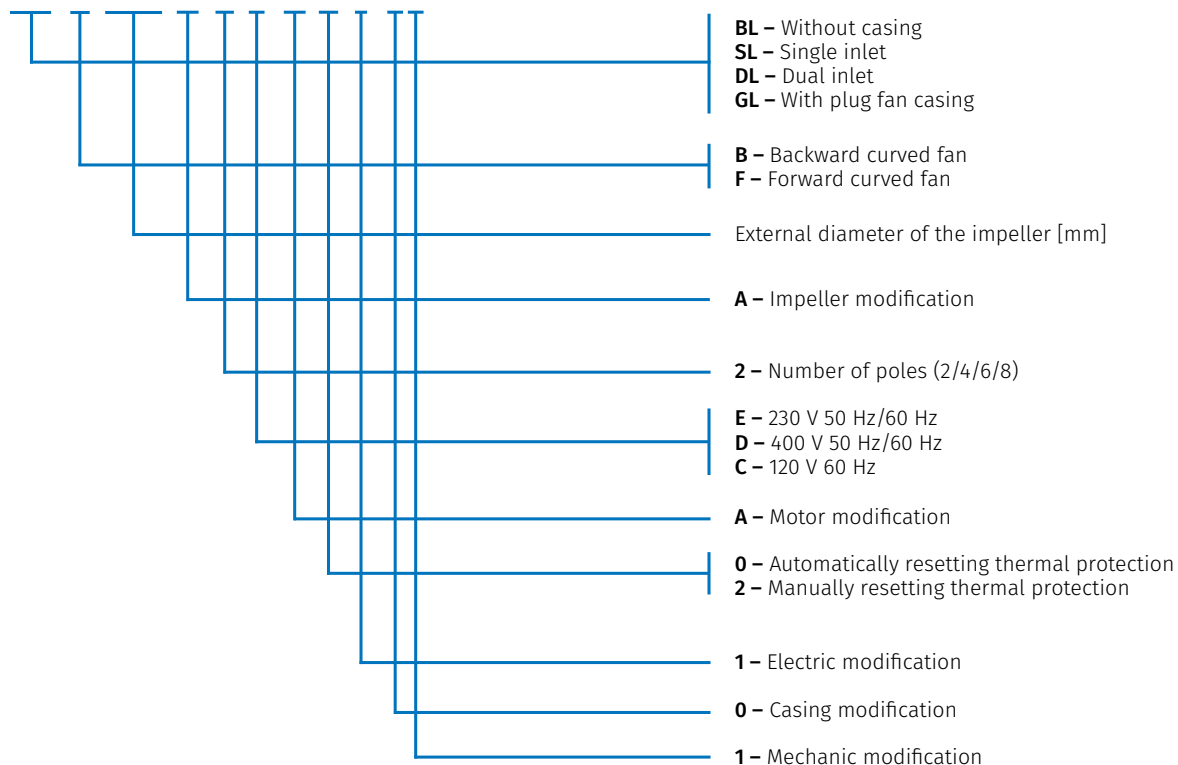

EC fans

BL-B190A-EC00

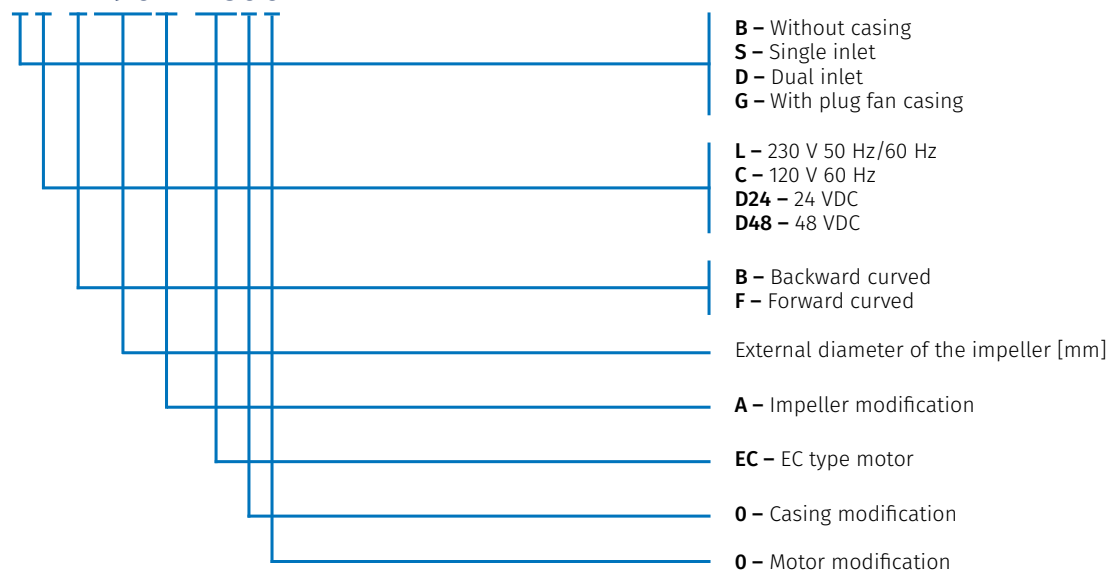

FORWARD CURVED EC CENTRIFUGAL FANS

Ø 108 MM, FORWARD CURVED

EC CENTRIFUGAL FAN



Features

- Speed control: 0 ~ 10 V DC/PWM
- Impeller material: galvanized steel
- Direction of rotation: clockwise, seen on rotor
- Type of protection: IP55
- Insulation class: B
- Mode of operation: continuous operation (S1)
- Bearing: ball bearings
- Motor protection: self-resetting TOP wired internally



Technical data

Model	Perform. curve	Nominal voltage [VAC]	Frequency [Hz]	Speed [RPM]	Power input max [W]	Current max [A]	Sound pres. level [dBA]	Perm. amb. temp. [°C]	Capacitor [µF/VDB]	Electrical connection
BL-F108A-EC-00	I	230	50/60	3340	82	0.65	67	-25 ... +60	-	E

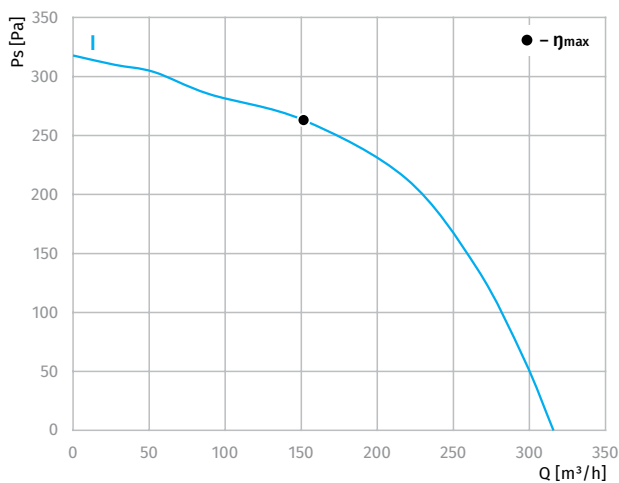

Overall dimensions

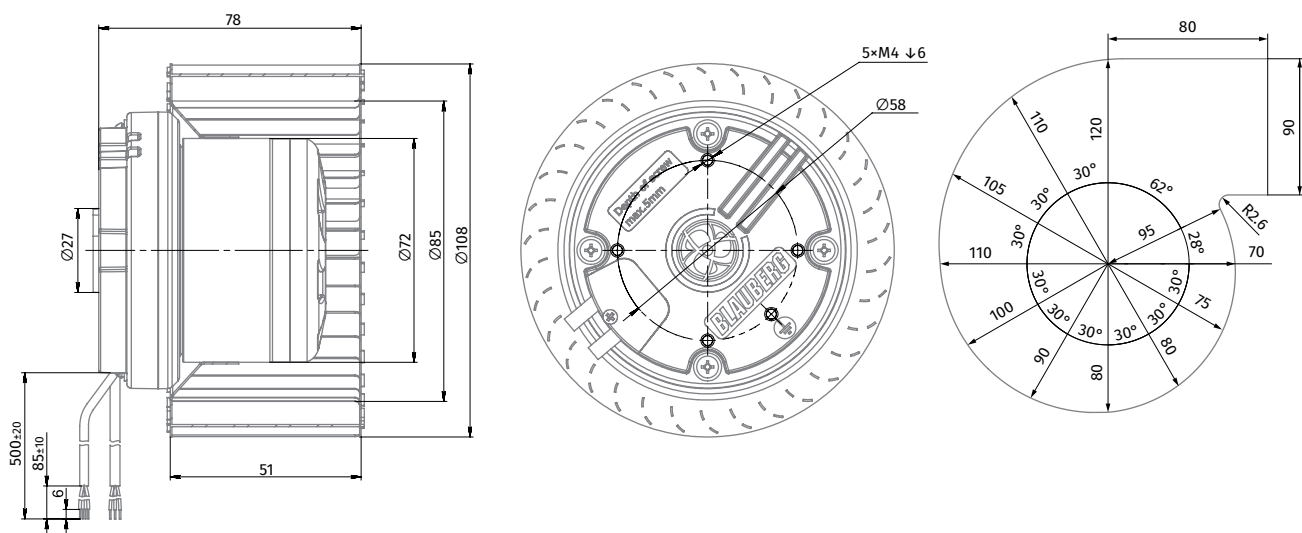

Ø 120 MM, FORWARD CURVED

EC CENTRIFUGAL FAN



Features

- Speed control: 0 ~ 10 V DC/PWM
- Impeller material: galvanized steel
- Direction of rotation: clockwise, seen on rotor
- Type of protection: IP55
- Insulation class: B
- Mode of operation: continuous operation (S1)
- Bearing: ball bearings
- Motor protection: self-resetting TOP wired internally



Technical data

Model	Perform. curve	Nominal voltage [VAC]	Frequency [Hz]	Speed [RPM]	Power input max [W]	Current max [A]	Sound pres. level [dBA]	Perm. amb. temp. [°C]	Capacitor [µF/VDB]	Electrical connection
BL-F120B-EC-00	I	230	50/60	2800	86	0.60	67	-25 ... +60	-	E

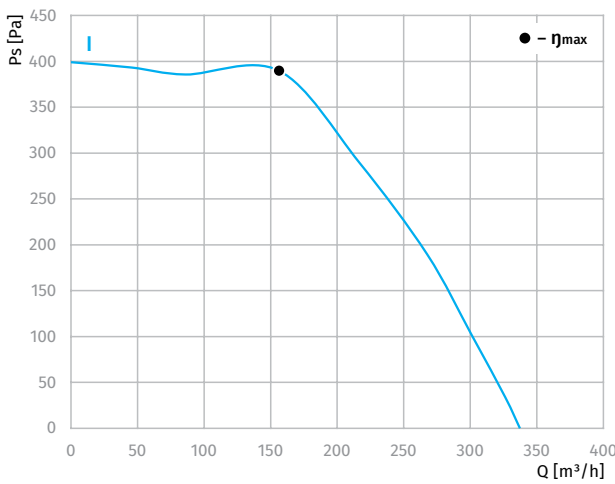

Overall dimensions

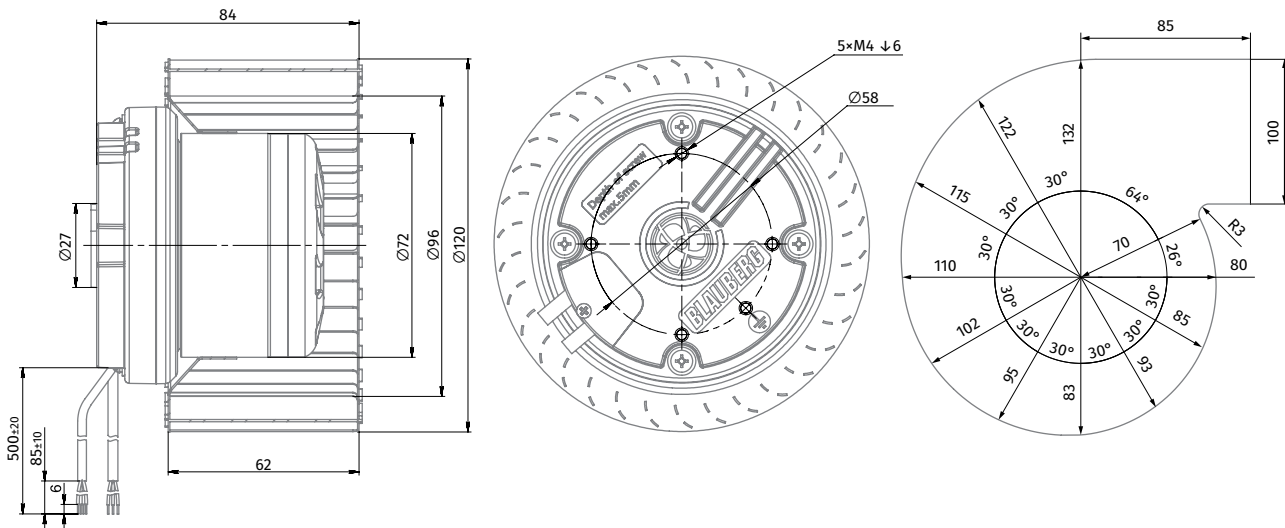

BACKWARD CURVED AC CENTRIFUGAL FANS

BACKWARD CURVED EC CENTRIFUGAL FANS

FORWARD CURVED AC CENTRIFUGAL FANS

FORWARD CURVED EC CENTRIFUGAL FANS

FORWARD CURVED AC BLOWERS

FORWARD CURVED EC BLOWERS

BACKWARD CURVED EC BLOWERS

Ø 140 MM, FORWARD CURVED

EC CENTRIFUGAL FAN



Features

- Speed control: 0 ~ 10 V DC/PWM
- Impeller material: galvanized steel
- Direction of rotation: clockwise, seen on rotor
- Type of protection: IP55
- Insulation class: B
- Mode of operation: continuous operation (S1)
- Bearing: ball bearings
- Motor protection: self-resetting TOP wired internally



Technical data

Model	Perform. curve	Nominal voltage [VAC]	Frequency [Hz]	Speed [RPM]	Power input max [W]	Current max [A]	Sound pres. level [dBA]	Perm. amb. temp. [°C]	Capacitor [µF/VDB]	Electrical connection
BL-F140B-EC-02	I	230	50/60	1700	66	0.60	72	-25 ... +60	-	E

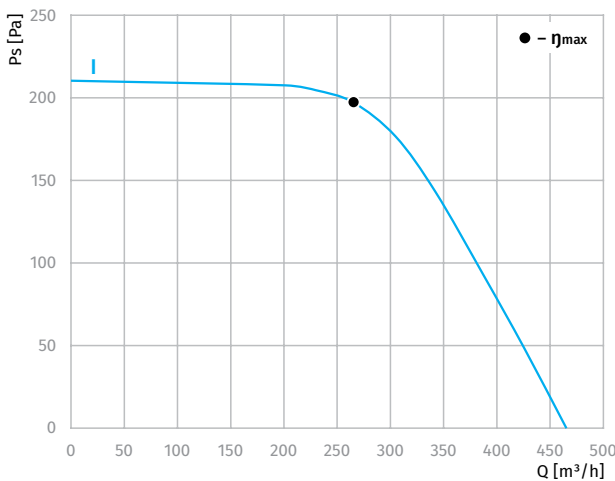

Overall dimensions

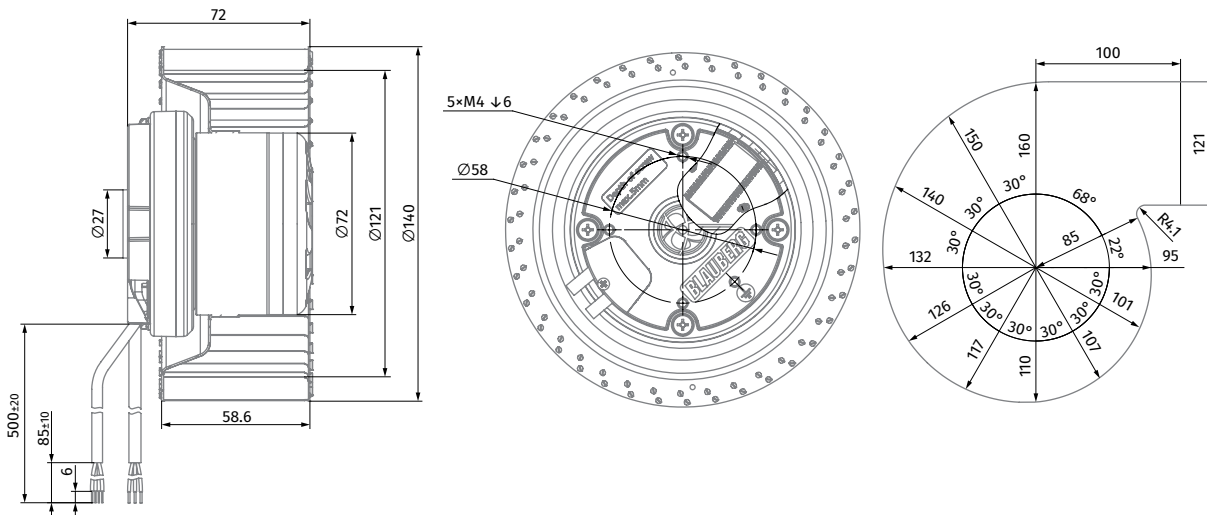

BACKWARD CURVED
AC CENTRIFUGAL FANS

BACKWARD CURVED
EC CENTRIFUGAL FANS

FORWARD CURVED
AC CENTRIFUGAL FANS

FORWARD CURVED
EC CENTRIFUGAL FANS

FORWARD CURVED
AC BLOWERS

FORWARD CURVED
EC BLOWERS

BACKWARD CURVED
EC BLOWERS

Ø 160 MM, FORWARD CURVED

EC CENTRIFUGAL FAN

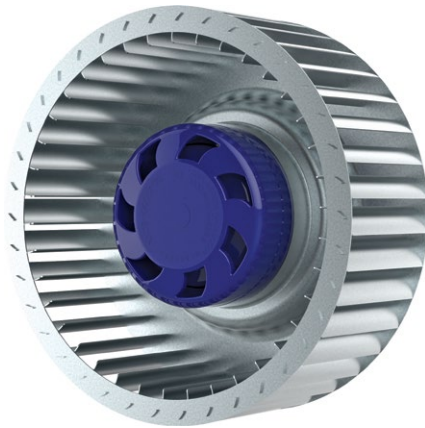

Features

- Speed control: 0 ~ 10 V DC/PWM
- Impeller material: galvanized steel
- Direction of rotation: clockwise, seen on rotor
- Type of protection: IP55
- Insulation class: B
- Mode of operation: continuous operation (S1)
- Bearing: ball bearings
- Motor protection: self-resetting TOP wired internally



Technical data

Model	Perform. curve	Nominal voltage [VAC]	Frequency [Hz]	Speed [RPM]	Power input max [W]	Current max [A]	Sound pres. level [dBA]	Perm. amb. temp. [°C]	Capacitor [µF/VDB]	Electrical connection
BL-F160C-EC-00	I	230	50/60	2600	179	1.30	70	-25 ... +60	-	E

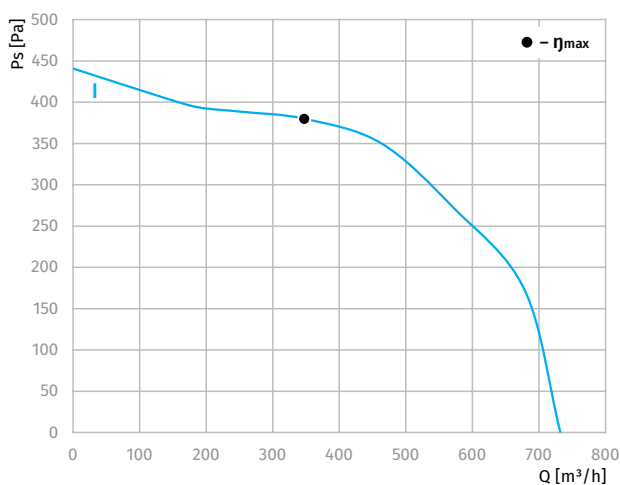

Overall dimensions

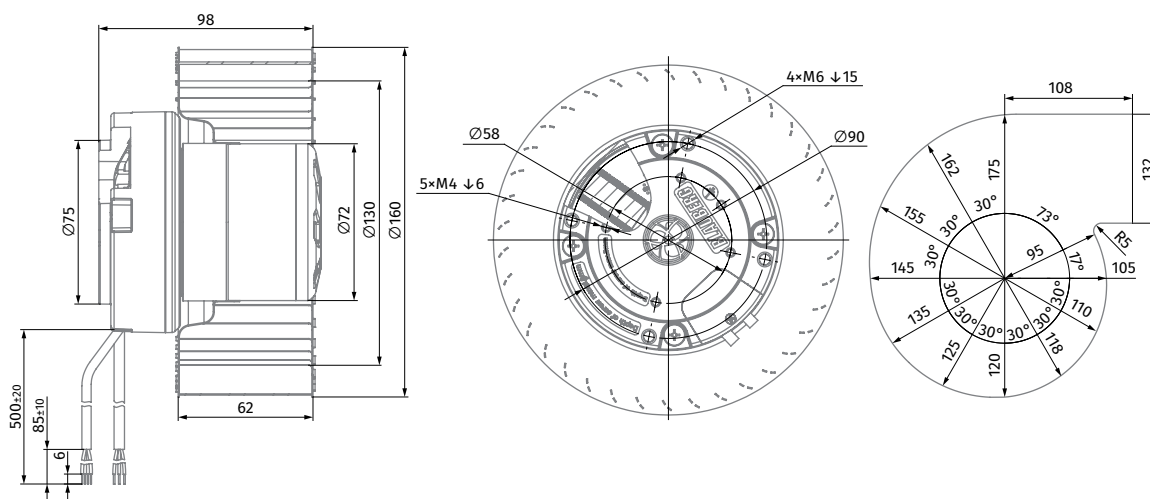

Ø 180 MM, FORWARD CURVED

EC CENTRIFUGAL FAN

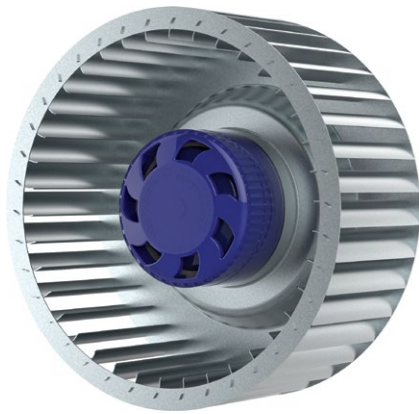

Features

- Speed control: 0 ~ 10 V DC/PWM
- Impeller material: galvanized steel
- Direction of rotation: clockwise, seen on rotor
- Type of protection: IP55
- Insulation class: B
- Mode of operation: continuous operation (S1)
- Bearing: ball bearings
- Motor protection: self-resetting TOP wired internally



Technical data

Model	Perform. curve	Nominal voltage [VAC]	Frequency [Hz]	Speed [RPM]	Power input max [W]	Current max [A]	Sound pres. level [dBA]	Perm. amb. temp. [°C]	Capacitor [µF/VDB]	Electrical connection
BL-F180C-EC-00	I	230	50/60	2200	100	0.80	70	-25 ... +60	-	E

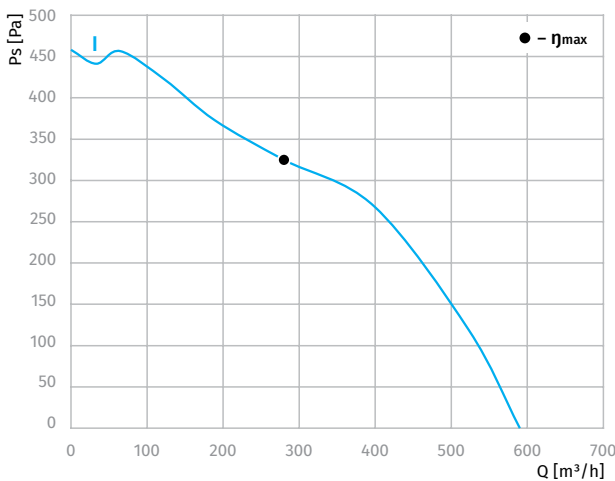

Overall dimensions

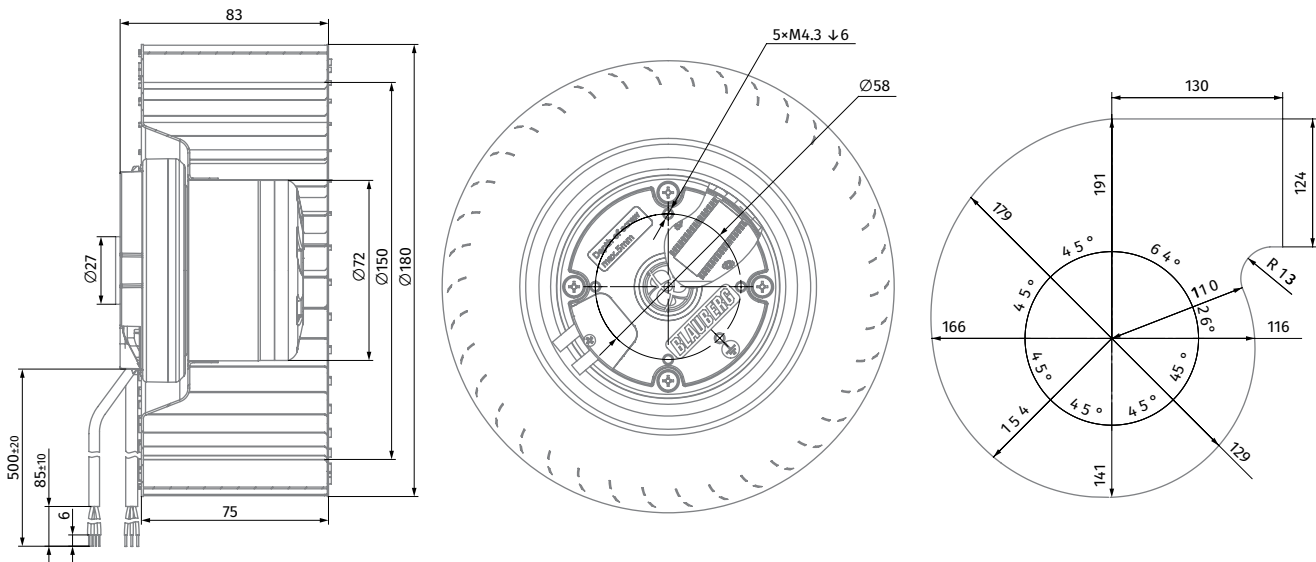

BACKWARD CURVED
AC CENTRIFUGAL FANS

BACKWARD CURVED
EC CENTRIFUGAL FANS

FORWARD CURVED
AC CENTRIFUGAL FANS

FORWARD CURVED
EC CENTRIFUGAL FANS

FORWARD CURVED
AC BLOWERS

FORWARD CURVED
EC BLOWERS

BACKWARD CURVED
EC BLOWERS

INLET RINGS

Inlet rings IR-PA series

- For backward curved blade impellers
- Made of high quality plastic

OVERALL DIMENSIONS [MM]

BLAUBERG Inlet ring	BLAUBERG Impeller size	A	B	C	D	RE	h	t	g	Fig.
IR 190BC PA	190	172	158	120.5	125.5	10	15.9	2.5	4.5	1
IR 220BC PA	220	258	245	149	153	20	21	2.0	4.5	2
IR 225BC PA	225	223	210.7	141	145	25	28	2.0	4.5	1
IR 250BC PA	250	255	240	160	164	28	31	2.0	4.5	1

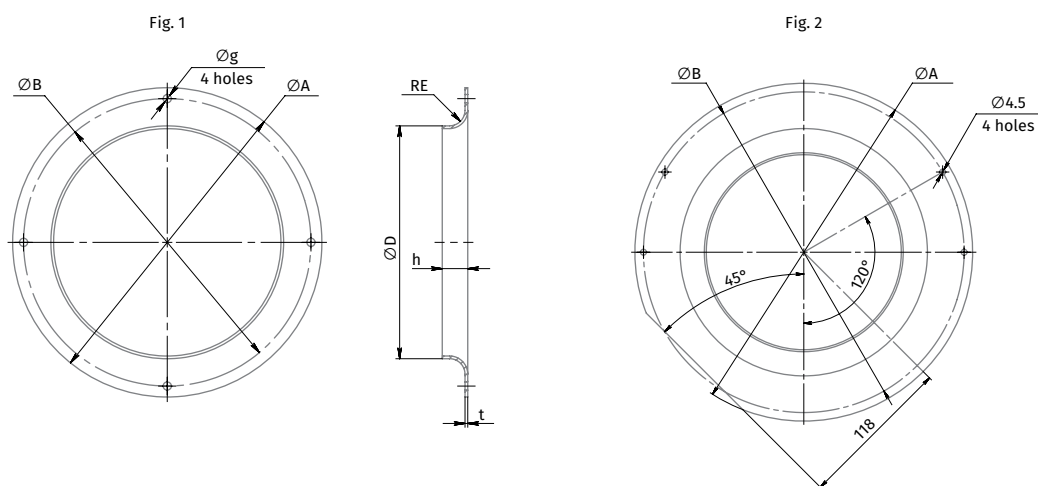

Inlet rings IR-GS series

- For backward curved blade impellers
- Made of galvanized steel

OVERALL DIMENSIONS [MM]

BLAUBERG Inlet ring	BLAUBERG Impeller size	DA	E	DE	Re	F-ØG	h	t
IR 190BC GS	190	170	158	125	10	4-Ø4.5	14	0.6
IR 220BC GS	220	252	236	152	22	4-Ø4.5	21	0.6
IR 225BC GS	225	223	210.7	145	21	4-Ø4.5	28	1.5
IR 250BC GS	250	255	240	164	18	4-Ø4.5	33	1.5

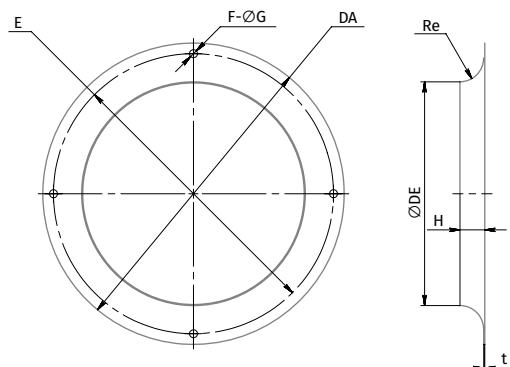

ELECTRICAL CONNECTION DIAGRAM

Type "A"

- U1 Blue
- U2 Black
- Z1 Brown
- PE Green/Yellow

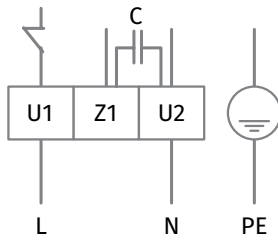

Type "B"

- U1 Blue
- U2 Black
- U3 Brown
- TK White
- PE Green/Yellow

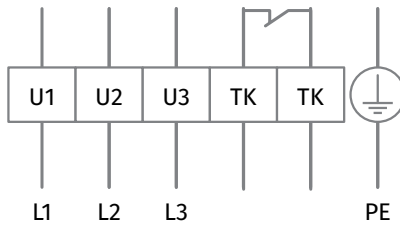

Type "E"

- U1 Brown
- U2 Blue
- PE Green/Yellow
- U4 Red
- U5 Yellow
- U6 White
- U7 Blue

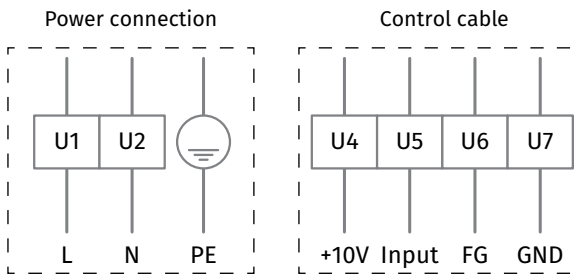

FORWARD CURVED AC CENTRIFUGAL FANS

Ø 120 MM, FORWARD CURVED

AC CENTRIFUGAL FAN



Features

- Impeller material: galvanized steel
- Direction of rotation: clockwise, seen on rotor
- Type of protection: IP44
- Insulation class: B
- Mode of operation: continuous operation (S1)
- Bearing: ball bearings
- Motor protection: self-resetting TOP wired internally



Technical data

Model	Perform. curve	Nominal voltage [VAC]	Frequency [Hz]	Speed [RPM]	Power input max [W]	Current max [A]	Sound pres. level [dBA]	Perm. amb. temp. [°C]	Capacitor [µF/VDB]	Electrical connection
BL-F120A-2E-A01-01	I	230	50	2900	67	0.29	60	-25 ... +50	1.5/450	A
	II	230	60	3400	84	0.32	63	-25 ... +50	1.5/450	A

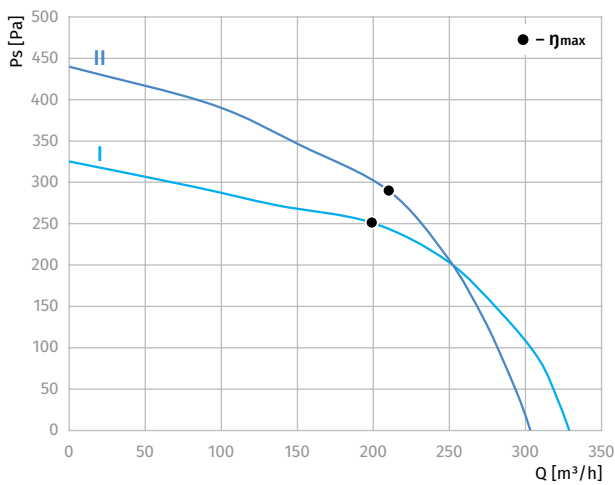

Overall dimensions

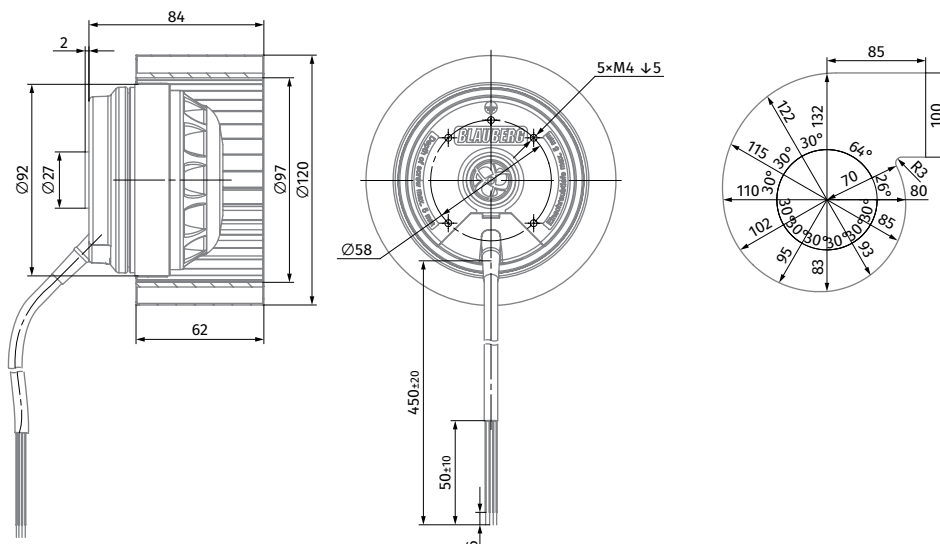

Ø 140 MM, FORWARD CURVED

AC CENTRIFUGAL FAN



Features

- Impeller material: galvanized steel
- Direction of rotation: clockwise, seen on rotor
- Type of protection: IP44
- Insulation class: B
- Mode of operation: continuous operation (S1)
- Bearing: ball bearings
- Motor protection: self-resetting TOP wired internally



Technical data

Model	Perform. curve	Nominal voltage [VAC]	Frequency [Hz]	Speed [RPM]	Power input max [W]	Current max [A]	Sound pres. level [dBA]	Perm. amb. temp. [°C]	Capacitor [µF/VDB]	Electrical connection
BL-F140A-2E-C01-01	I	230	50	2800	168	0.7	72	-25 ... +50	3.5/450	A
	II	230	60	3300	190	0.8	71	-25 ... +50	3.5/450	A
BL-F140A-4E-B01-01	III	230	50	1500	52	0.23	70	-25 ... +50	2.0/450	A
	IV	230	60	1700	67	0.30	71	-25 ... +50	2.0/450	A

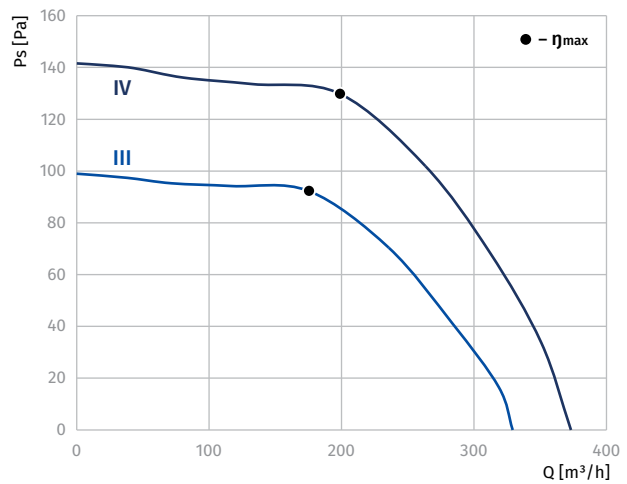
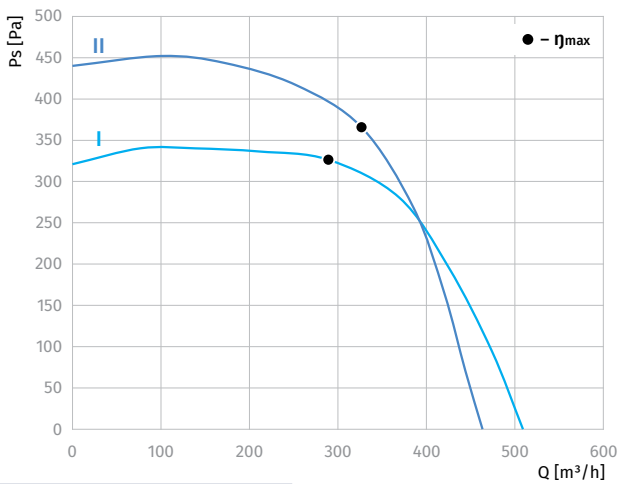

Overall dimensions

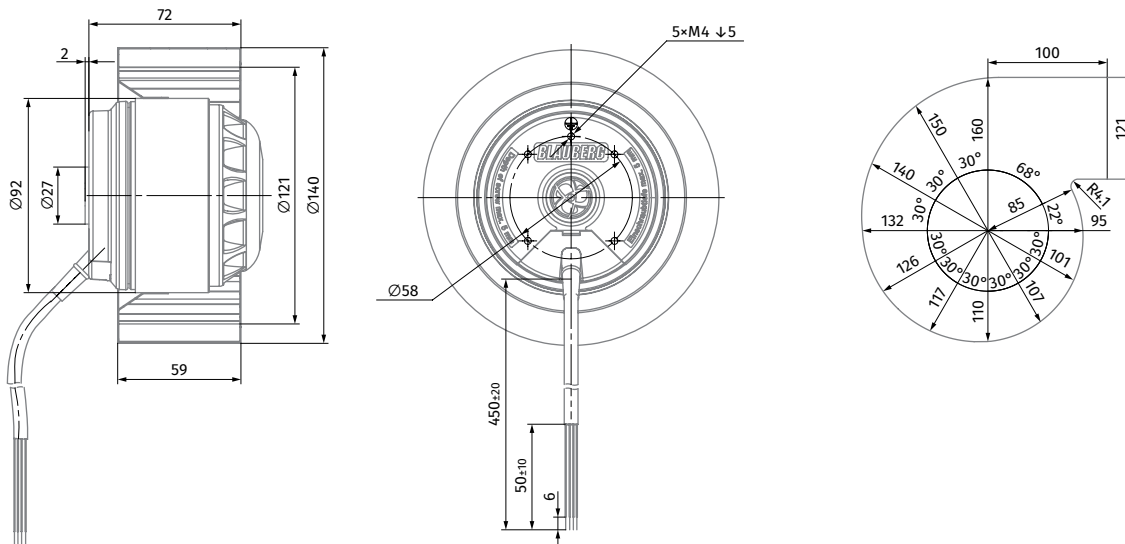

BACKWARD CURVED AC CENTRIFUGAL FANS

BACKWARD CURVED EC CENTRIFUGAL FANS

FORWARD CURVED AC CENTRIFUGAL FANS

FORWARD CURVED EC CENTRIFUGAL FANS

FORWARD CURVED AC BLOWERS

FORWARD CURVED EC BLOWERS

BACKWARD CURVED EC BLOWERS

Ø 160 MM, FORWARD CURVED

AC CENTRIFUGAL FAN



Features

- Impeller material: galvanized steel
- Direction of rotation: clockwise, seen on rotor
- Type of protection: IP44
- Insulation class: B, F
- Mode of operation: continuous operation (S1)
- Bearing: ball bearings
- Motor protection: self-resetting TOP wired internally



Technical data

Model	Perform. curve	Nominal voltage [VAC]	Frequency [Hz]	Speed [RPM]	Power input max [W]	Current max [A]	Sound pres. level [dBA]	Perm. amb. temp. [°C]	Capacitor [µF/VDB]	Electrical connection
BL-F160A-4E-B01-01	I	230	50	1500	72	0.32	66	-25 ... +50	1.5/450	A
	II	230	60	1700	84	0.37	68	-25 ... +50	1.5/450	A
BL-F160A-2E-D01-01	III	230	50	2800	340	1.50	71	-25 ... +50	6.0/450	A
BL-F160A-2E-D02-01	IV	230	50	2850	250	1.10	68	-25 ... +50	6.0/450	A
	V	230	60	3250	270	1.20	72	-25 ... +50	6.0/450	A

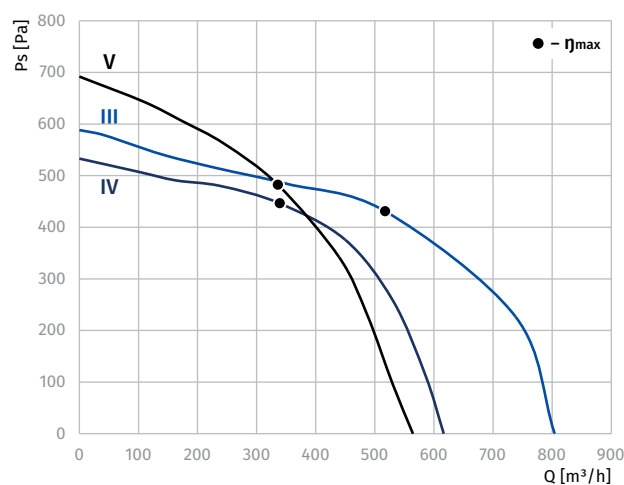
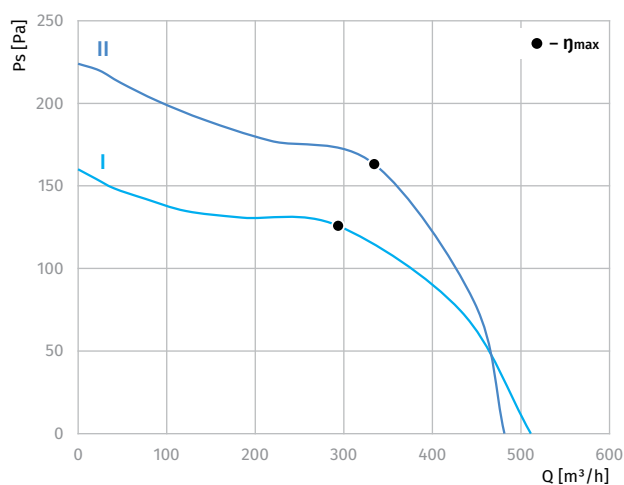

Overall dimensions

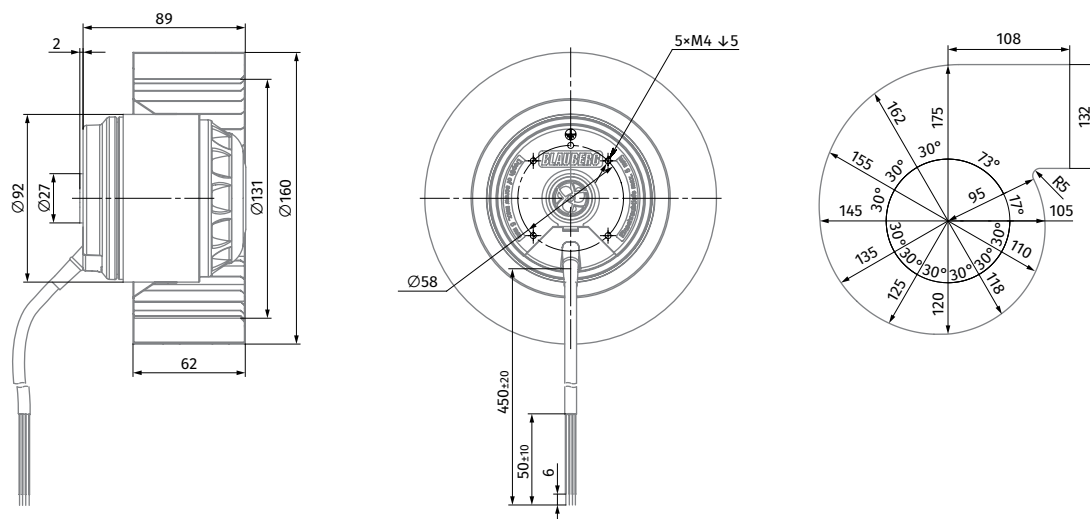

Ø 200 MM, FORWARD CURVED

AC CENTRIFUGAL FAN



Features

- Impeller material: galvanized steel
- Direction of rotation: clockwise, seen on rotor
- Type of protection: IP44
- Insulation class: F
- Mode of operation: continuous operation (S1)
- Bearing: ball bearings
- Motor protection: self-resetting TOP wired internally



Technical data

Model	Perform. curve	Nominal voltage [VAC]	Frequency [Hz]	Speed [RPM]	Power input max [W]	Current max [A]	Sound pres. level [dBA]	Perm. amb. temp. [°C]	Capacitor [µF/VDB]	Electrical connection
BL-F200A-4E-C01-01	I	230	50	1400	134	0.59	65	-25 ... +40	3.0/450	A
	II	230	60	1600	154	0.67	67	-25 ... +40	3.0/450	A

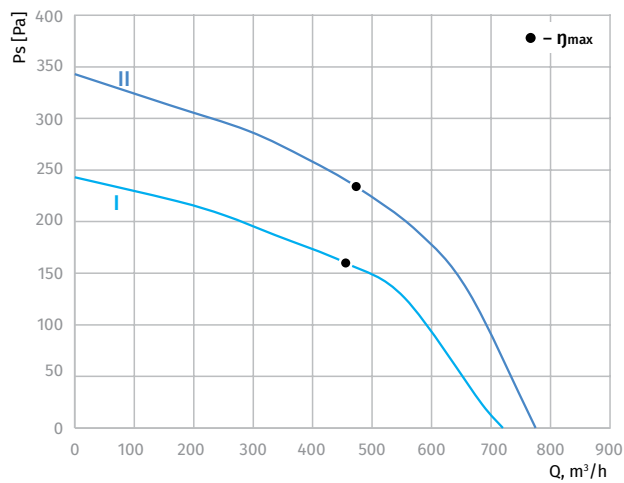

Overall dimensions

