

ANTIKORROSIVA FLÄKTAR

Centrifugalfäktar, byggda i polypropen, avsedda för industriella installationer i aggressiva miljöer, såsom kemisk industri, batterirum eller annat.

Serie P



- Material: Tryck-gjuten i polypropen
- Turbin: polypropen
- Motorstativ: stål med epoxi lackering
- Skruvar etc: rostfritt stål

Serie P-20

Serie di ventilatori a pale rovesce.

Versioni:

Standard: coclea stampata Pe - girante PP - supporto motore in lamiera di acciaio verniciato polveri - viteria acciaio INOX

ATEX: coclea stampata Pe-el conduttivo - girante PP - supporto motore in lamiera di acciaio verniciato polveri - viteria acciaio INOX

Fans series with backward curved blades.

Versions:

Standard: Pe moulded housing - PP impeller - epoxy painted motor support - stainless steel screws

ATEX: Pe-el antistatic housing - PP impeller - epoxy painted motor support - stainless steel screws

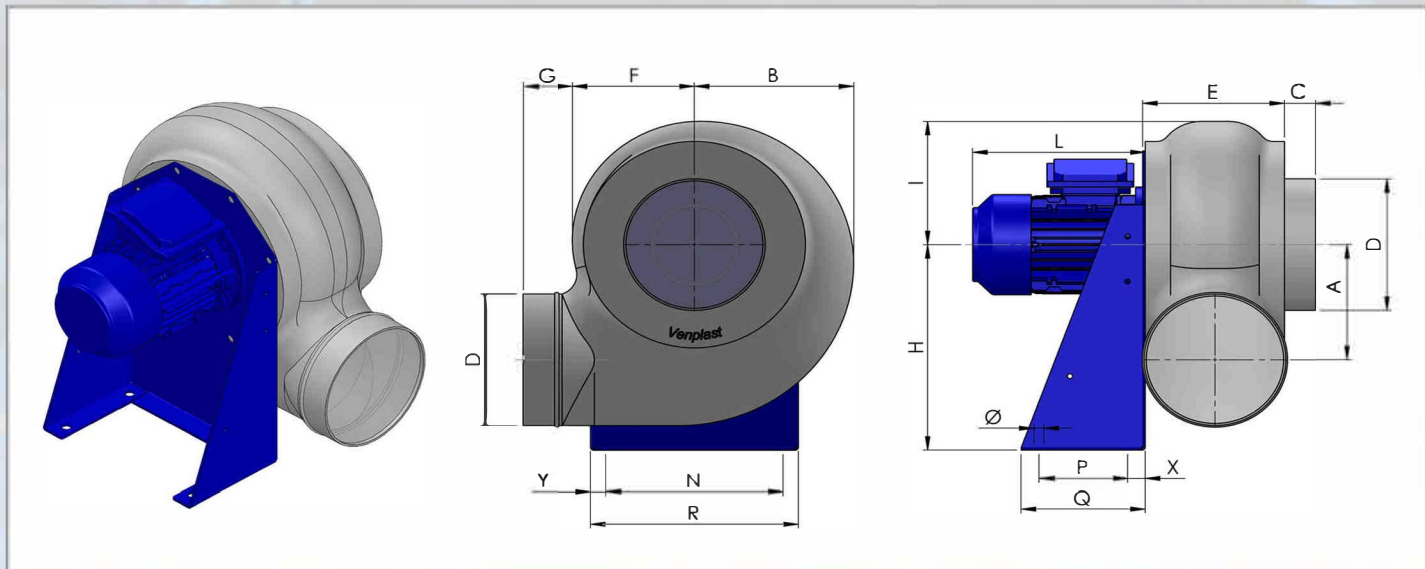

Tipo Type	Mot.Gr. Size	Mot. Kw	Giri Rpm	A	B	C	D	E	F	G	H	I	L	N	P	Q	R	Y	X	Ø	KG.*	KG.**
P 204	63	0.12	1370	140	180	35	160	160	138	55	250	150	190	200	100	140	235	17,5	20	11	9	17
P 202	63	0.18	2750	140	180	35	160	160	138	55	250	150	195	200	100	140	235	17,5	20	11	9	17
P 224	63	0.12	1370	173	228	35	200	185	170	55	310	190	190	255	100	140	290	17,5	20	11	10	18
P 222	63	0.25	2800	173	228	35	200	185	170	55	310	190	210	225	100	140	290	17,5	20	11	13	24
P 254	63	0.12	1370	173	228	35	200	185	170	55	310	190	190	255	100	140	290	17,5	20	11	10	18
P 252	71	0.37	2800	173	228	35	200	185	170	55	310	190	220	255	100	140	290	17,5	20	11	13	24
P 284	63	0.18	1370	208	255	40	225	195	190	70	350	210	190	280	120	190	316	18	35	11	14	23
P 282	80	0.75	2850	208	255	40	225	195	190	70	350	210	240	280	120	190	316	18	35	11	19	33
P 316	71	0.18	930	240	280	40	250	200	210	70	410	230	210	320	150	230	355	17,5	40	11	19	30
P 314	71	0.25	1400	240	280	40	250	200	210	70	410	230	220	320	150	230	355	17,5	40	11	19	30
P 312	90	1.50	2850	240	280	40	250	200	210	70	410	230	290	320	150	230	355	17,5	40	11	26	45
P 356	71	0.18	930	260	312	40	280	237	230	55	445	270	210	355	150	230	390	17,5	40	11	23	34
P 354	71	0.37	1400	260	312	40	280	237	230	55	445	270	220	355	150	230	390	17,5	40	11	23	34
P 352	90	2.20	2870	260	312	40	280	237	230	55	445	270	290	355	150	230	390	17,5	40	11	32	51
P 406	71	0.25	920	290	356	40	315	252	264	55	495	295	220	325	170	250	365	20	40	11	30	41
P 404	80	0.55	1410	290	356	40	315	252	264	55	495	295	240	325	170	250	365	20	40	11	33	47
P 456	80	0.37	920	324	400	40	355	287	295	55	550	330	240	370	170	250	410	20	40	11	37	51
P 454	90	1.10	1410	324	400	40	355	287	295	55	550	330	290	370	170	250	410	20	40	11	40	61
P 452	100	4.0	2860	324	400	40	355	287	295	55	550	330	415	370	270	340	410	20	40	11	57	72

* esecuzione con motore standard – standard motor execution

** esecuzione ATEX – ATEX execution

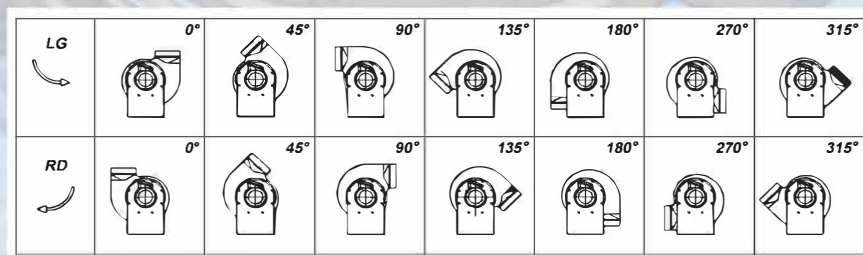

Venplast srl

P 20

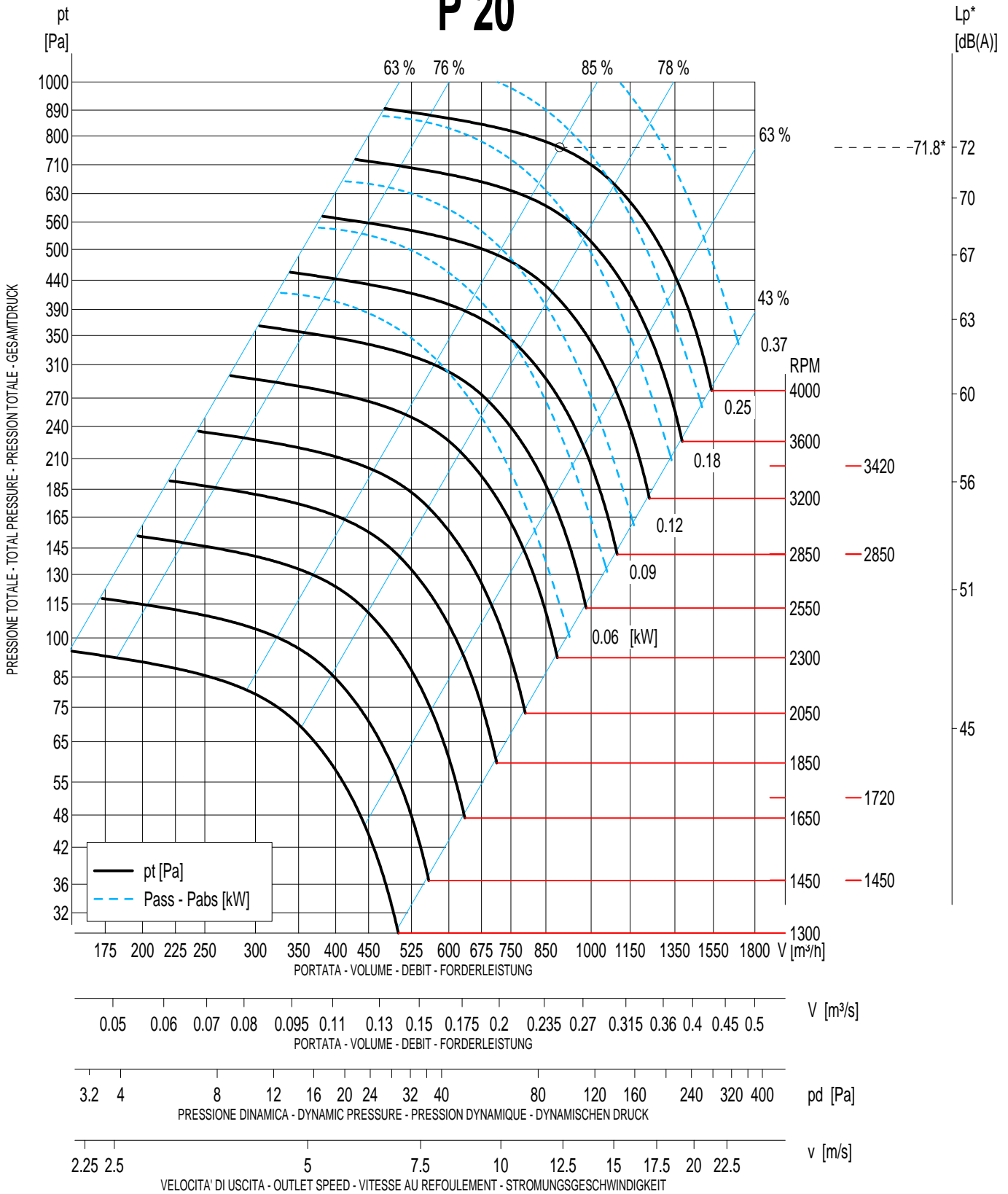

Livello potenza sonora totale - Total sound power level - Gesamt schalleistungspegel - Niveau totale de puissance sonore - [dB] *									
RPM	Banda d'ottava - Octave band - Oktav-Band - Bande d'octave [Hz]								Lp* dB(A)
	63	125	250	500	1000	2000	4000	8000	
1450	62.3	64.3	65.3	60.3	59.3	54.3	46.3	38.3	49
1720	66.1	68.1	69.1	64.1	63.1	58.1	50.1	42.1	53
2000	69.5	71.5	72.5	67.5	66.5	61.5	53.5	45.5	56
2850	77.3	79.3	77.3	78.3	74.3	69.3	61.3	53.3	64.7
3420	81.3	83.3	81.3	82.3	78.3	73.3	65.3	57.3	68.7

(*) Al massimo rendimento - At max. efficiency - (Distanza-distance-abstand-distance : 1.5 [m])

Temperatura - Temperature - Temperatur - Température : 15 [°] - Densità - Density - Bezugsdichte - Densité : 1.225 [kg/m³]

Tolleranza sulla portata ±5% - Capacity tolerance ±5% - Tolérance sur le débit ±5% - Fördertoleranz ±5%

I valori relativi alla rumorosità sono riferiti ad una misurazione in campo libero, con una tolleranza di +3 dB(A)

Noise values refer to a free field measurement with a tolerance of +3 dB(A)

Les valeurs relatives à la bruyance se réfèrent à un mesurage en champ libre, avec une tolérance de +3 dB(A)

Die die Geräuschentwicklung betreffenden Werte beziehen sich auf eine Freifeld-Messung bei einer Toleranz von +3 dB(A)

PD² - WD² - GD² - PD² : 0.003 kgm²

Serie P-22

Serie di ventilatori a pale rovesce.

Versioni:

Standard: coclea stampata Pe - girante PP - supporto motore in lamiera di acciaio verniciato polveri - viteria acciaio INOX

ATEX: coclea stampata Pe-el conduttivo - girante PP - supporto motore in lamiera di acciaio verniciato polveri - viteria acciaio INOX

Fans series with backward curved blades.

Versions:

Standard: Pe moulded housing - PP impeller - epoxy painted motor support - stainless steel screws

ATEX: Pe-el antistatic housing - PP impeller - epoxy painted motor support - stainless steel screws

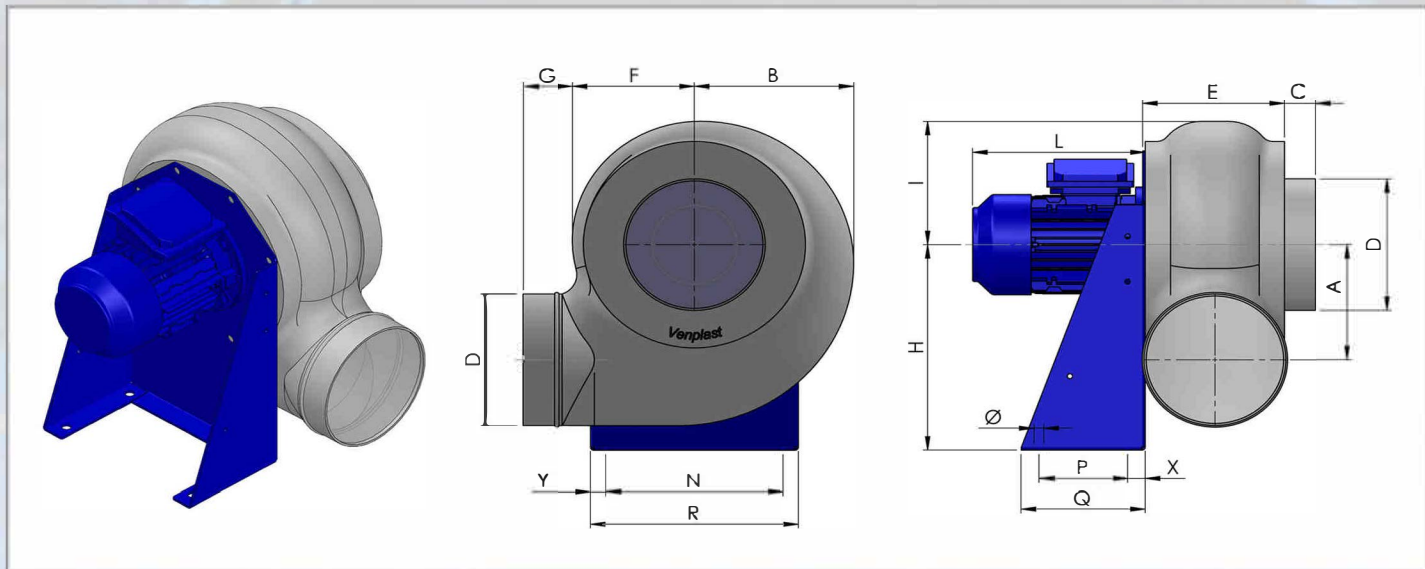

Tipo Type	Mot.Gr. Size	Mot. Kw	Giri Rpm	A	B	C	D	E	F	G	H	I	L	N	P	Q	R	Y	X	Ø	KG.*	KG.**
P 204	63	0.12	1370	140	180	35	160	160	138	55	250	150	190	200	100	140	235	17,5	20	11	9	17
P 202	63	0.18	2750	140	180	35	160	160	138	55	250	150	195	200	100	140	235	17,5	20	11	9	17
P 224	63	0.12	1370	173	228	35	200	185	170	55	310	190	190	255	100	140	290	17,5	20	11	10	18
P 222	63	0.25	2800	173	228	35	200	185	170	55	310	190	210	225	100	140	290	17,5	20	11	13	24
P 254	63	0.12	1370	173	228	35	200	185	170	55	310	190	190	255	100	140	290	17,5	20	11	10	18
P 252	71	0.37	2800	173	228	35	200	185	170	55	310	190	220	255	100	140	290	17,5	20	11	13	24
P 284	63	0.18	1370	208	255	40	225	195	190	70	350	210	190	280	120	190	316	18	35	11	14	23
P 282	80	0.75	2850	208	255	40	225	195	190	70	350	210	240	280	120	190	316	18	35	11	19	33
P 316	71	0.18	930	240	280	40	250	200	210	70	410	230	210	320	150	230	355	17,5	40	11	19	30
P 314	71	0.25	1400	240	280	40	250	200	210	70	410	230	220	320	150	230	355	17,5	40	11	19	30
P 312	90	1.50	2850	240	280	40	250	200	210	70	410	230	290	320	150	230	355	17,5	40	11	26	45
P 356	71	0.18	930	260	312	40	280	237	230	55	445	270	210	355	150	230	390	17,5	40	11	23	34
P 354	71	0.37	1400	260	312	40	280	237	230	55	445	270	220	355	150	230	390	17,5	40	11	23	34
P 352	90	2.20	2870	260	312	40	280	237	230	55	445	270	290	355	150	230	390	17,5	40	11	32	51
P 406	71	0.25	920	290	356	40	315	252	264	55	495	295	220	325	170	250	365	20	40	11	30	41
P 404	80	0.55	1410	290	356	40	315	252	264	55	495	295	240	325	170	250	365	20	40	11	33	47
P 456	80	0.37	920	324	400	40	355	287	295	55	550	330	240	370	170	250	410	20	40	11	37	51
P 454	90	1.10	1410	324	400	40	355	287	395	55	550	330	290	370	170	250	410	20	40	11	40	61
P 452	100	4.0	2860	324	400	40	355	287	295	55	550	330	415	370	270	340	410	20	40	11	57	72

* esecuzione con motore standard – standard motor execution

** esecuzione ATEX – ATEX execution

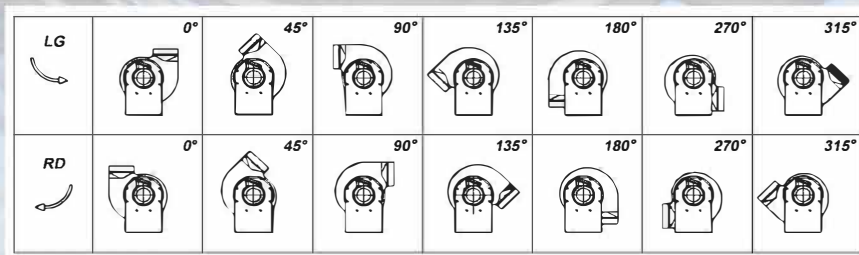

Venplast srl

P 22

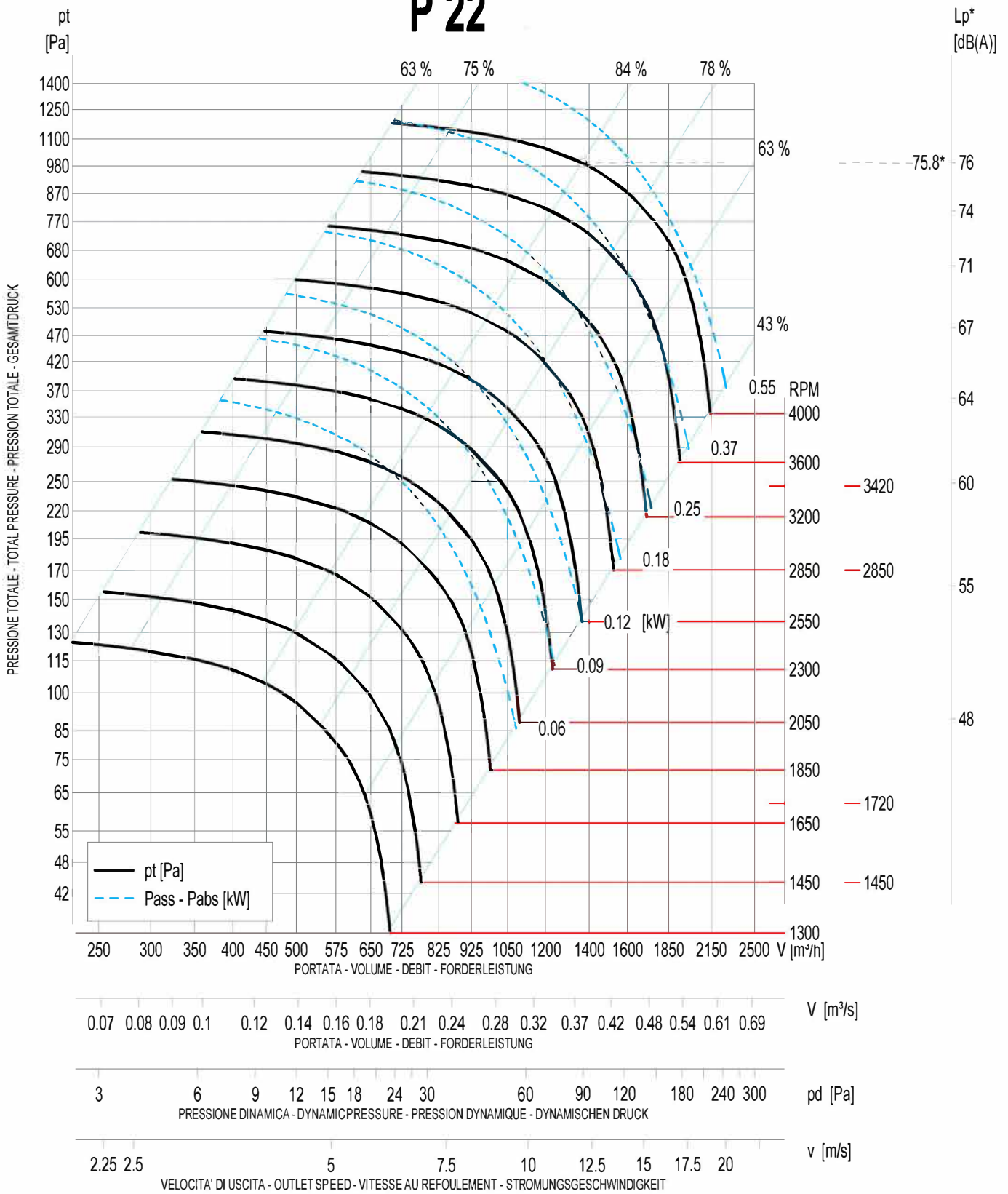

Livello potenza sonora totale - Total sound power level - Gesamt schalleistungspegel - Niveau totale de puissance sonore - [dB] *									
RPM	Banda d'ottava - Octave band - Oktav-Band - Bande d'octave [Hz]								Lp* dB(A)
	63	125	250	500	1000	2000	4000	8000	
1450	66	68	69	64	63	58	50	42	52.1
1720	69.8	71.8	72.8	67.8	66.8	61.8	53.8	45.8	56.1
2000	73.1	75.1	76.1	71.1	70.1	65.1	57.1	49.1	60
2850	81	83	81	82	78	73	65	57	67.8
3420	85	87	85	86	82	77	69	61	71.8

(* Al massimo rendimento - At max. efficiency - (Distanza-distance-abstand-distance : 1.5 [m])

Temperatura - Temperature - Temperatur - Température : 15 [°] - Densità - Density - Bezugsdichte - Densité : 1.225 [kg/m³]

Tolleranza sulla portata ±5% - Capacity tolerance ±5% - Tolérance sur le débit ±5% - Fördertoleranz ±5%

I valori relativi alla rumorosità sono riferiti ad una misurazione in campo libero, con una tolleranza di +3 dB(A)

Noise values refer to a free field measurement with a tolerance of +3 dB(A)

Les valeurs relatives à la bruyance se réfèrent à un mesurage en champ libre, avec une tolérance de +3 dB(A)

Die die Geräuschentwicklung betreffenden Werte beziehen sich auf eine Freifeld-Messung bei einer Toleranz von +3 dB(A)

PD² - WD² - GD² - PD² : 0.008 kgm²

Serie **P-25**

Serie di ventilatori a pale rovesce.

Versioni:

Standard: coclea stampata Pe - girante PP - supporto motore in lamiera di acciaio verniciato polveri - viteria acciaio INOX

ATEX: coclea stampata Pe-el conduttivo - girante PP - supporto motore in lamiera di acciaio verniciato polveri - viteria acciaio INOX

Fans series with backward curved blades.

Versions:

Standard: Pe moulded housing - PP impeller - epoxy painted motor support - stainless steel screws

ATEX: Pe-el antistatic housing - PP impeller - epoxy painted motor support - stainless steel screws

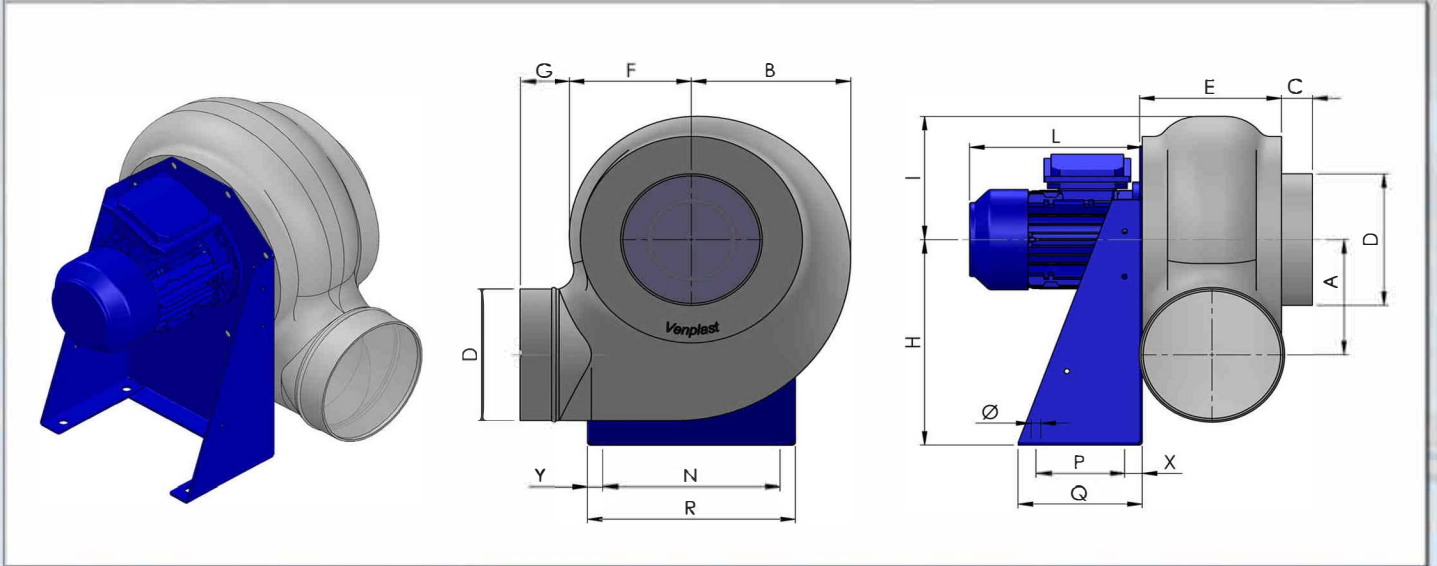

Tipo Type	Mot.Gr. Size	Mot. Kw	Giri Rpm	A	B	C	D	E	F	G	H	I	L	N	P	Q	R	Y	X	Ø	KG.*	KG.**
P 204	63	0.12	1370	140	180	35	160	160	138	55	250	150	190	200	100	140	235	17,5	20	11	9	17
P 202	63	0.18	2750	140	180	35	160	160	138	55	250	150	195	200	100	140	235	17,5	20	11	9	17
P 224	63	0.12	1370	173	228	35	200	185	170	55	310	190	190	255	100	140	290	17,5	20	11	10	18
P 222	63	0.25	2800	173	228	35	200	185	170	55	310	190	210	225	100	140	290	17,5	20	11	13	24
P 254	63	0.12	1370	173	228	35	200	185	170	55	310	190	190	255	100	140	290	17,5	20	11	10	18
P 252	71	0.37	2800	173	228	35	200	185	170	55	310	190	220	255	100	140	290	17,5	20	11	13	24
P 284	63	0.18	1370	208	255	40	225	195	190	70	350	210	190	280	120	190	316	18	35	11	14	23
P 282	80	0.75	2850	208	255	40	225	195	190	70	350	210	240	280	120	190	316	18	35	11	19	33
P 316	71	0.18	930	240	280	40	250	200	210	70	410	230	210	320	150	230	355	17,5	40	11	19	30
P 314	71	0.25	1400	240	280	40	250	200	210	70	410	230	220	320	150	230	355	17,5	40	11	19	30
P 312	90	1.50	2850	240	280	40	250	200	210	70	410	230	290	320	150	230	355	17,5	40	11	26	45
P 356	71	0.18	930	260	312	40	280	237	230	55	445	270	210	355	150	230	390	17,5	40	11	23	34
P 354	71	0.37	1400	260	312	40	280	237	230	55	445	270	220	355	150	230	390	17,5	40	11	23	34
P 352	90	2.20	2870	260	312	40	280	237	230	55	445	270	290	355	150	230	390	17,5	40	11	32	51
P 406	71	0.25	920	290	356	40	315	252	264	55	495	295	220	325	170	250	365	20	40	11	30	41
P 404	80	0.55	1410	290	356	40	315	252	264	55	495	295	240	325	170	250	365	20	40	11	33	47
P 456	80	0.37	920	324	400	40	355	287	295	55	550	330	240	370	170	250	410	20	40	11	37	51
P 454	90	1.10	1410	324	400	40	355	287	295	55	550	330	290	370	170	250	410	20	40	11	40	61
P 452	100	4.0	2860	324	400	40	355	287	295	55	550	330	415	370	270	340	410	20	40	11	57	72

* esecuzione con motore standard – standard motor execution

** esecuzione ATEX – ATEX execution

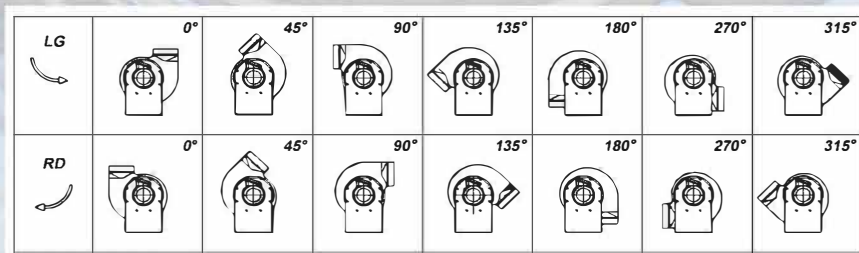

Venplast srl

P 25

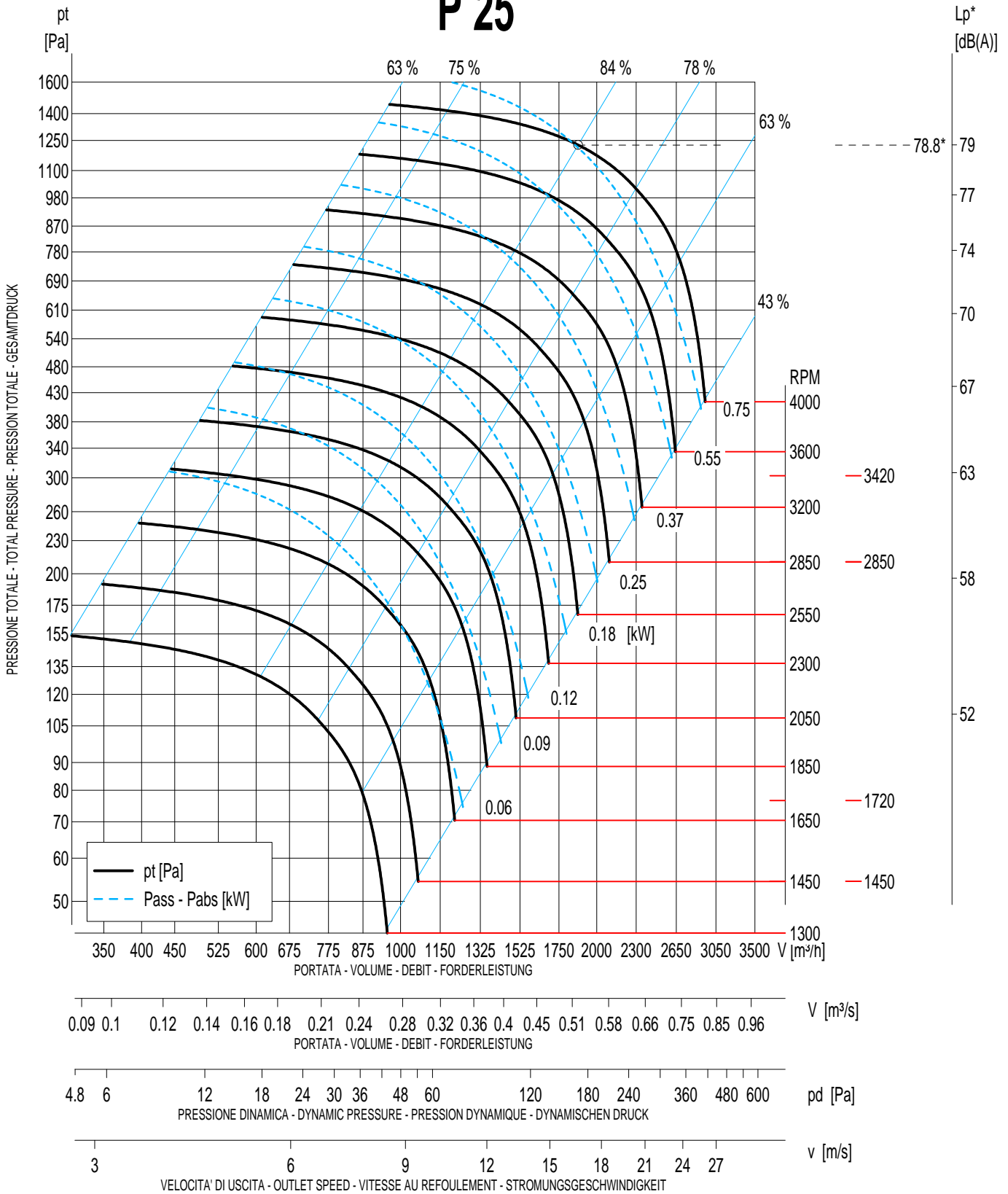

Livello potenza sonora totale - Total sound power level - Gesamt schalleistungspegel - Niveau totale de puissance sonore - [dB] *									
RPM	Banda d'ottava - Octave band - Oktav-Band - Bande d'octave [Hz]								Lp* dB(A)
	63	125	250	500	1000	2000	4000	8000	
1450	69.3	71.3	72.3	67.3	66.3	61.3	53.3	45.3	56
1720	73	75	76	71	70	65	57	49	59.1
2000	76.4	78.4	79.4	74.4	73.4	68.4	60.4	52.4	63
2850	84.2	86.2	84.2	85.2	81.2	76.2	68.2	60.2	71.7
3420	88.3	90.3	88.3	89.3	85.3	80.3	72.3	64.3	75.7

(*) Al massimo rendimento - At max. efficiency - (Distanza-distance-abstand-distance : 1.5 [m])

Temperatura - Temperature - Temperatur - Température : 15 [°] - Densità - Density - Bezugsdichte - Densité : 1.225 [kg/m³]

Tolleranza sulla portata ±5% - Capacity tolerance ±5% - Tolérance sur le débit ±5% - Fördertoleranz ±5%

I valori relativi alla rumorosità sono riferiti ad una misurazione in campo libero, con una tolleranza di +3 dB(A)

Noise values refer to a free field measurement with a tolerance of +3 dB(A)

Les valeurs relatives à la bruyance se réfèrent à un mesurage en champ libre, avec une tolérance de +3 dB(A)

Die die Geräuschentwicklung betreffenden Werte beziehen sich auf eine Freifeld-Messung bei einer Toleranz von +3 dB(A)

PD² - WD² - GD² - PD² : 0.008 kgm²

Serie P-28

Serie di ventilatori a pale rovesce.

Versioni:

Standard: coclea stampata Pe - girante PP - supporto motore in lamiera di acciaio verniciato polveri - viteria acciaio INOX

ATEX: coclea stampata Pe-el conduttivo - girante PP - supporto motore in lamiera di acciaio verniciato polveri - viteria acciaio INOX

Fans series with backward curved blades.

Versions:

Standard: Pe moulded housing - PP impeller - epoxy painted motor support - stainless steel screws

ATEX: Pe-el antistatic housing - PP impeller - epoxy painted motor support - stainless steel screws

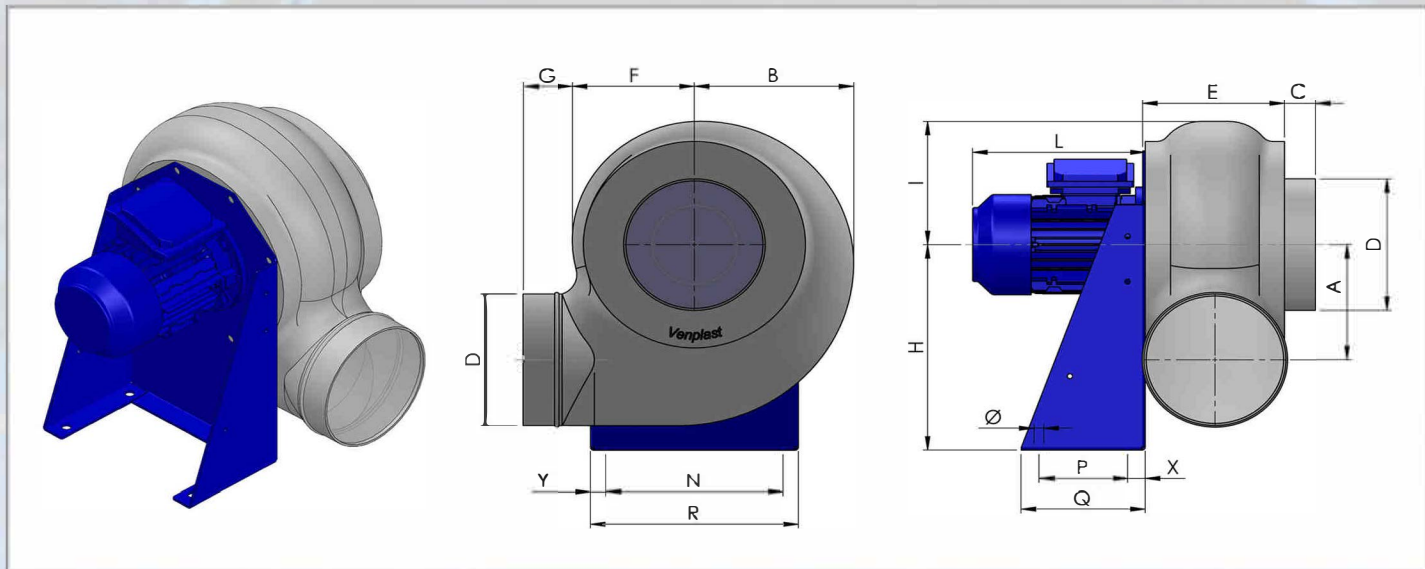

Tipo Type	Mot.Gr. Size	Mot. Kw	Giri Rpm	A	B	C	D	E	F	G	H	I	L	N	P	Q	R	Y	X	Ø	KG.*	KG.**
P 204	63	0.12	1370	140	180	35	160	160	138	55	250	150	190	200	100	140	235	17,5	20	11	9	17
P 202	63	0.18	2750	140	180	35	160	160	138	55	250	150	195	200	100	140	235	17,5	20	11	9	17
P 224	63	0.12	1370	173	228	35	200	185	170	55	310	190	190	255	100	140	290	17,5	20	11	10	18
P 222	63	0.25	2800	173	228	35	200	185	170	55	310	190	210	225	100	140	290	17,5	20	11	13	24
P 254	63	0.12	1370	173	228	35	200	185	170	55	310	190	190	255	100	140	290	17,5	20	11	10	18
P 252	71	0.37	2800	173	228	35	200	185	170	55	310	190	220	255	100	140	290	17,5	20	11	13	24
P 284	63	0.18	1370	208	255	40	225	195	190	70	350	210	190	280	120	190	316	18	35	11	14	23
P 282	80	0.75	2850	208	255	40	225	195	190	70	350	210	240	280	120	190	316	18	35	11	19	33
P 316	71	0.18	930	240	280	40	250	200	210	70	410	230	210	320	150	230	355	17,5	40	11	19	30
P 314	71	0.25	1400	240	280	40	250	200	210	70	410	230	220	320	150	230	355	17,5	40	11	19	30
P 312	90	1.50	2850	240	280	40	250	200	210	70	410	230	290	320	150	230	355	17,5	40	11	26	45
P 356	71	0.18	930	260	312	40	280	237	230	55	445	270	210	355	150	230	390	17,5	40	11	23	34
P 354	71	0.37	1400	260	312	40	280	237	230	55	445	270	220	355	150	230	390	17,5	40	11	23	34
P 352	90	2.20	2870	260	312	40	280	237	230	55	445	270	290	355	150	230	390	17,5	40	11	32	51
P 406	71	0.25	920	290	356	40	315	252	264	55	495	295	220	325	170	250	365	20	40	11	30	41
P 404	80	0.55	1410	290	356	40	315	252	264	55	495	295	240	325	170	250	365	20	40	11	33	47
P 456	80	0.37	920	324	400	40	355	287	295	55	550	330	240	370	170	250	410	20	40	11	37	51
P 454	90	1.10	1410	324	400	40	355	287	295	55	550	330	290	370	170	250	410	20	40	11	40	61
P 452	100	4.0	2860	324	400	40	355	287	295	55	550	330	415	370	270	340	410	20	40	11	57	72

* esecuzione con motore standard – standard motor execution

** esecuzione ATEX – ATEX execution

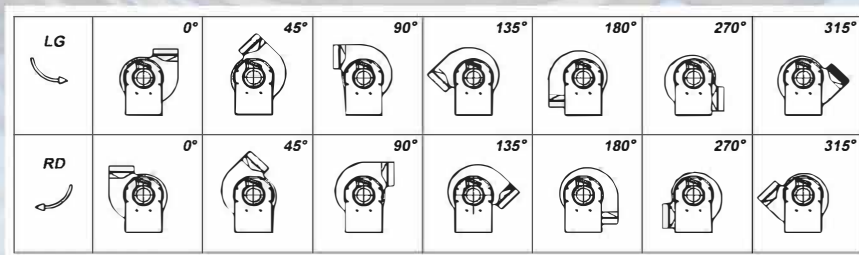

Venplast srl

P 28

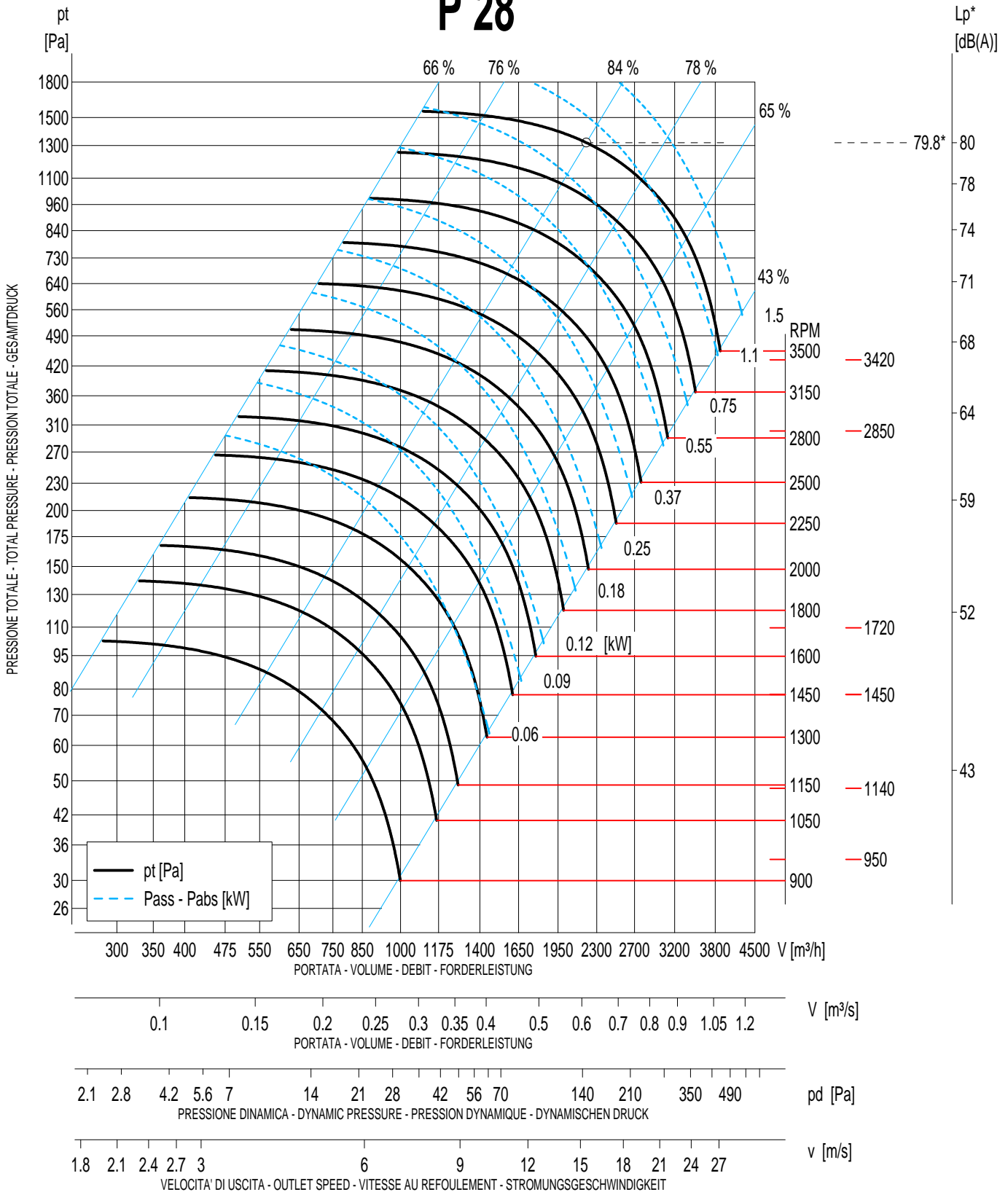

Livello potenza sonora totale - Total sound power level - Gesamt schalleistungspegel - Niveau totale de puissance sonore - [dB] *									
RPM	Banda d'ottava - Octave band - Oktav-Band - Bande d'octave [Hz]								Lp* dB(A)
	63	125	250	500	1000	2000	4000	8000	
900	62.5	67.5	62.5	60.5	59.5	54.5	46.5	38.5	48.8
1140	67.7	72.7	67.7	65.7	64.7	59.7	51.7	43.7	53.9
1450	73	75	76	71	70	65	57	49	59.1
1720	76.8	78.8	79.8	74.8	73.8	68.8	60.8	52.8	63.1
2850	88	90	88	89	85	80	72	64	74.8

(* Al massimo rendimento - At max. efficiency - (Distanza-distance-abstand-distance : 1.5 [m])

Temperatura - Temperature - Temperatur - Température : 15 [°] - Densità - Density - Bezugsdichte - Densité : 1.225 [kg/m³]

Tolleranza sulla portata ±5% - Capacity tolerance ±5% - Tolérance sur le débit ±5% - Fördertoleranz ±5%

I valori relativi alla rumorosità sono riferiti ad una misurazione in campo libero, con una tolleranza di +3 dB(A)

Noise values refer to a free field measurement with a tolerance of +3 dB(A)

Les valeurs relatives à la bruyance se réfèrent à un mesurage en champ libre, avec une tolérance de +3 dB(A)

Die die Geräuschentwicklung betreffenden Werte beziehen sich auf eine Freifeld-Messung bei einer Toleranz von +3 dB(A)

PD² - WD² - GD² - PD² : 0.017 kgm²

Serie P-31

Serie di ventilatori a pale rovesce.

Versioni:

Standard: coclea stampata Pe - girante PP - supporto motore in lamiera di acciaio verniciato polveri - viteria acciaio INOX

ATEX: coclea stampata Pe-el conduttivo - girante PP - supporto motore in lamiera di acciaio verniciato polveri - viteria acciaio INOX

Fans series with backward curved blades.

Versions:

Standard: Pe moulded housing - PP impeller - epoxy painted motor support - stainless steel screws

ATEX: Pe-el antistatic housing - PP impeller - epoxy painted motor support - stainless steel screws

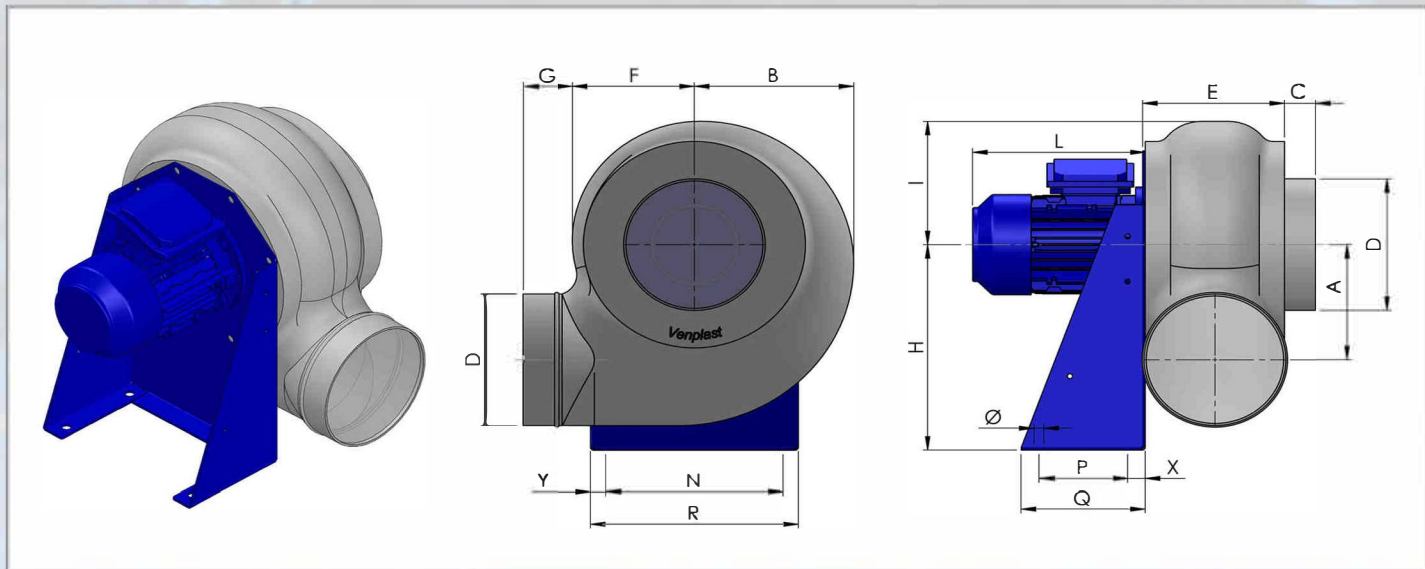

Tipo Type	Mot.Gr. Size	Mot. Kw	Giri Rpm	A	B	C	D	E	F	G	H	I	L	N	P	Q	R	Y	X	Ø	KG.*	KG.**
P 204	63	0.12	1370	140	180	35	160	160	138	55	250	150	190	200	100	140	235	17,5	20	11	9	17
P 202	63	0.18	2750	140	180	35	160	160	138	55	250	150	195	200	100	140	235	17,5	20	11	9	17
P 224	63	0.12	1370	173	228	35	200	185	170	55	310	190	190	255	100	140	290	17,5	20	11	10	18
P 222	63	0.25	2800	173	228	35	200	185	170	55	310	190	210	225	100	140	290	17,5	20	11	13	24
P 254	63	0.12	1370	173	228	35	200	185	170	55	310	190	190	255	100	140	290	17,5	20	11	10	18
P 252	71	0.37	2800	173	228	35	200	185	170	55	310	190	220	255	100	140	290	17,5	20	11	13	24
P 284	63	0.18	1370	208	255	40	225	195	190	70	350	210	190	280	120	190	316	18	35	11	14	23
P 282	80	0.75	2850	208	255	40	225	195	190	70	350	210	240	280	120	190	316	18	35	11	19	33
P 316	71	0.18	930	240	280	40	250	200	210	70	410	230	210	320	150	230	355	17,5	40	11	19	30
P 314	71	0.25	1400	240	280	40	250	200	210	70	410	230	220	320	150	230	355	17,5	40	11	19	30
P 312	90	1.50	2850	240	280	40	250	200	210	70	410	230	290	320	150	230	355	17,5	40	11	26	45
P 356	71	0.18	930	260	312	40	280	237	230	55	445	270	210	355	150	230	390	17,5	40	11	23	34
P 354	71	0.37	1400	260	312	40	280	237	230	55	445	270	220	355	150	230	390	17,5	40	11	23	34
P 352	90	2.20	2870	260	312	40	280	237	230	55	445	270	290	355	150	230	390	17,5	40	11	32	51
P 406	71	0.25	920	290	356	40	315	252	264	55	495	295	220	325	170	250	365	20	40	11	30	41
P 404	80	0.55	1410	290	356	40	315	252	264	55	495	295	240	325	170	250	365	20	40	11	33	47
P 456	80	0.37	920	324	400	40	355	287	295	55	550	330	240	370	170	250	410	20	40	11	37	51
P 454	90	1.10	1410	324	400	40	355	287	295	55	550	330	290	370	170	250	410	20	40	11	40	61
P 452	100	4.0	2860	324	400	40	355	287	295	55	550	330	415	370	270	340	410	20	40	11	57	72

* esecuzione con motore standard – standard motor execution

** esecuzione ATEX – ATEX execution

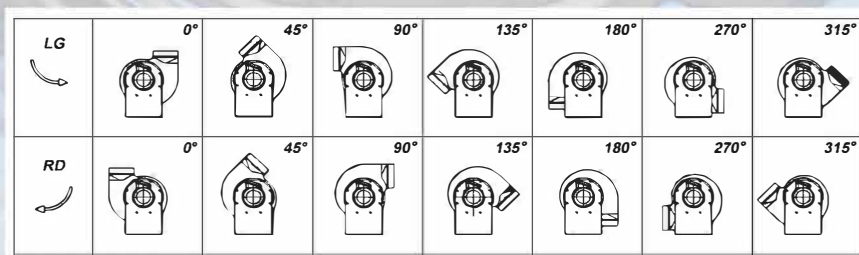

Venplast srl

P 31

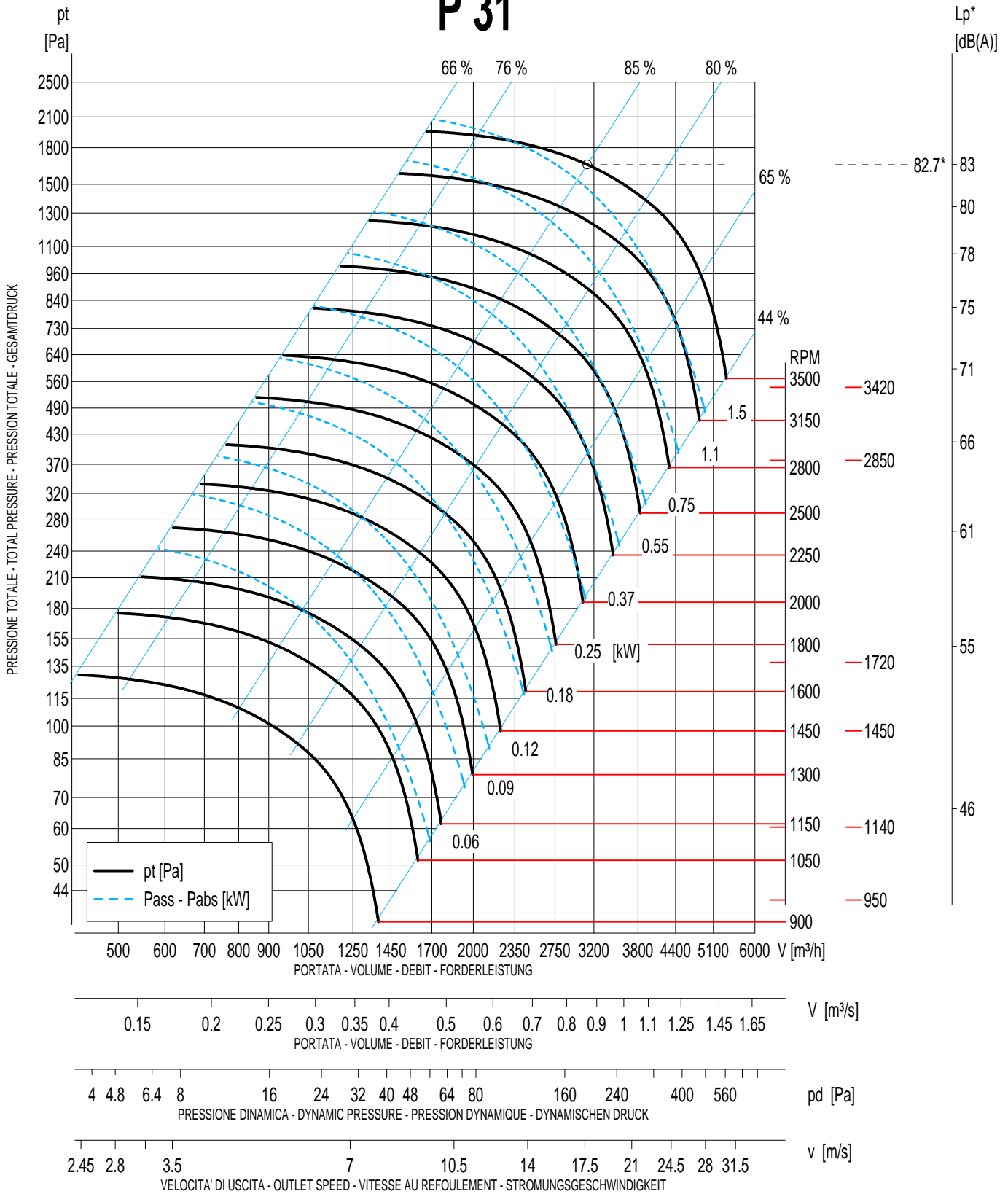

Livello potenza sonora totale - Total sound power level - Gesamt schalleistungspegel - Niveau totale de puissance sonore - [dB] *									
RPM	Banda d'ottava - Octave band - Oktav-Band - Bande d'octave [Hz]								Lp* dB(A)
	63	125	250	500	1000	2000	4000	8000	
900	65.2	70.2	65.2	63.2	62.2	57.2	49.2	41.2	51.8
1140	70.4	72.4	73.4	68.4	67.4	62.4	54.4	46.4	57
1450	75.7	77.7	78.7	73.7	72.7	67.7	59.7	51.7	62.1
2850	90.7	92.7	90.7	91.7	87.7	82.7	74.7	66.7	77.8
3420	94.7	96.7	94.7	95.7	91.7	86.7	78.7	70.7	81.8

(*) Al massimo rendimento - At max. efficiency - (Distanza-distance-abstand-distance : 1.5 [m])

Temperatura - Temperature - Temperatur - Température : 15 [°] - Densità - Density - Bezugsdichte - Densité : 1.225 [kg/m³]

Tolleranza sulla portata ±5% - Capacity tolerance ±5% - Tolérance sur le débit ±5% - Fördertoleranz ±5%

I valori relativi alla rumorosità sono riferiti ad una misurazione in campo libero, con una tolleranza di +3 dB(A)

Noise values refer to a free field measurement with a tolerance of +3 dB(A)

Les valeurs relatives à la bruyance se réfèrent à un mesurage en champ libre, avec une tolérance de +3 dB(A)

Die die Geräuschentwicklung betreffenden Werte beziehen sich auf eine Freifeld-Messung bei einer Toleranz von +3 dB(A)

PD² - WD² - GD² - PD² : 0.026 kgm²

Serie P-35

Serie di ventilatori a pale rovesce.

Versioni:

Standard: coclea stampata Pe - girante PP - supporto motore in lamiera di acciaio verniciato polveri - viteria acciaio INOX

ATEX: coclea stampata Pe-el conduttivo - girante PP - supporto motore in lamiera di acciaio verniciato polveri - viteria acciaio INOX

Fans series with backward curved blades.

Versions:

Standard: Pe moulded housing - PP impeller - epoxy painted motor support - stainless steel screws

ATEX: Pe-el antistatic housing - PP impeller - epoxy painted motor support - stainless steel screws

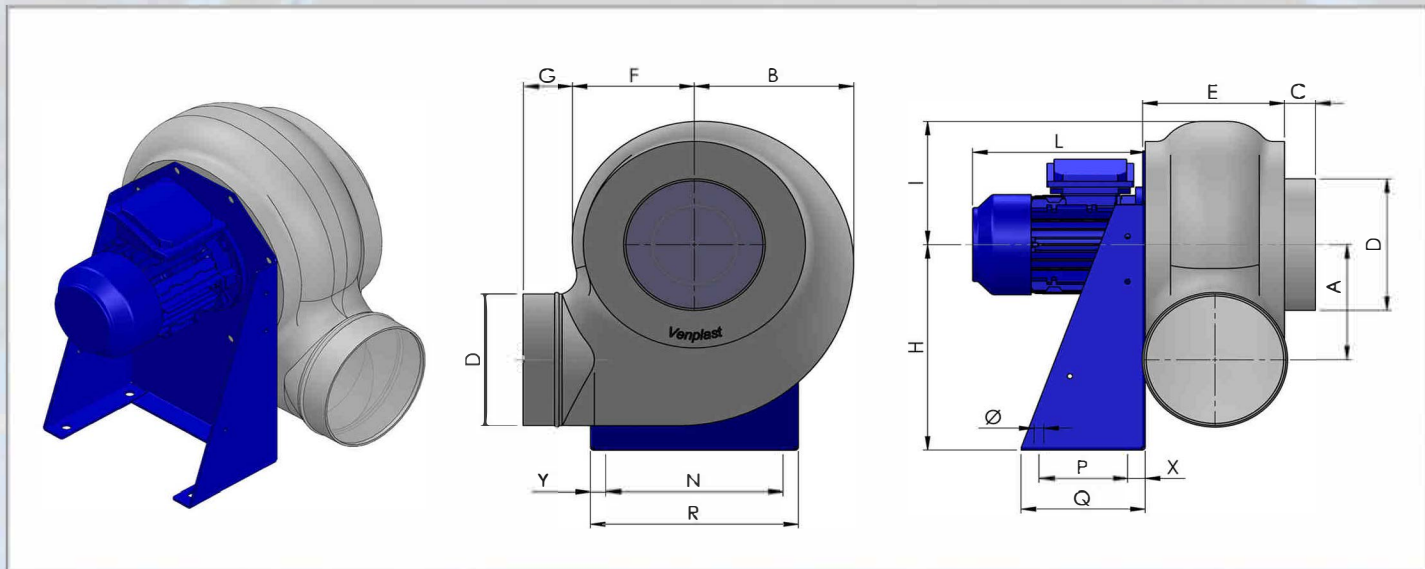

Tipo Type	Mot.Gr. Size	Mot. Kw	Giri Rpm	A	B	C	D	E	F	G	H	I	L	N	P	Q	R	Y	X	Ø	KG.*	KG.**
P 204	63	0.12	1370	140	180	35	160	160	138	55	250	150	190	200	100	140	235	17,5	20	11	9	17
P 202	63	0.18	2750	140	180	35	160	160	138	55	250	150	195	200	100	140	235	17,5	20	11	9	17
P 224	63	0.12	1370	173	228	35	200	185	170	55	310	190	190	255	100	140	290	17,5	20	11	10	18
P 222	63	0.25	2800	173	228	35	200	185	170	55	310	190	210	225	100	140	290	17,5	20	11	13	24
P 254	63	0.12	1370	173	228	35	200	185	170	55	310	190	190	255	100	140	290	17,5	20	11	10	18
P 252	71	0.37	2800	173	228	35	200	185	170	55	310	190	220	255	100	140	290	17,5	20	11	13	24
P 284	63	0.18	1370	208	255	40	225	195	190	70	350	210	190	280	120	190	316	18	35	11	14	23
P 282	80	0.75	2850	208	255	40	225	195	190	70	350	210	240	280	120	190	316	18	35	11	19	33
P 316	71	0.18	930	240	280	40	250	200	210	70	410	230	210	320	150	230	355	17,5	40	11	19	30
P 314	71	0.25	1400	240	280	40	250	200	210	70	410	230	220	320	150	230	355	17,5	40	11	19	30
P 312	90	1.50	2850	240	280	40	250	200	210	70	410	230	290	320	150	230	355	17,5	40	11	26	45
P 356	71	0.18	930	260	312	40	280	237	230	55	445	270	210	355	150	230	390	17,5	40	11	23	34
P 354	71	0.37	1400	260	312	40	280	237	230	55	445	270	220	355	150	230	390	17,5	40	11	23	34
P 352	90	2.20	2870	260	312	40	280	237	230	55	445	270	290	355	150	230	390	17,5	40	11	32	51
P 406	71	0.25	920	290	356	40	315	252	264	55	495	295	220	325	170	250	365	20	40	11	30	41
P 404	80	0.55	1410	290	356	40	315	252	264	55	495	295	240	325	170	250	365	20	40	11	33	47
P 456	80	0.37	920	324	400	40	355	287	295	55	550	330	240	370	170	250	410	20	40	11	37	51
P 454	90	1.10	1410	324	400	40	355	287	295	55	550	330	290	370	170	250	410	20	40	11	40	61
P 452	100	4.0	2860	324	400	40	355	287	295	55	550	330	415	370	270	340	410	20	40	11	57	72

* esecuzione con motore standard – standard motor execution

** esecuzione ATEX – ATEX execution

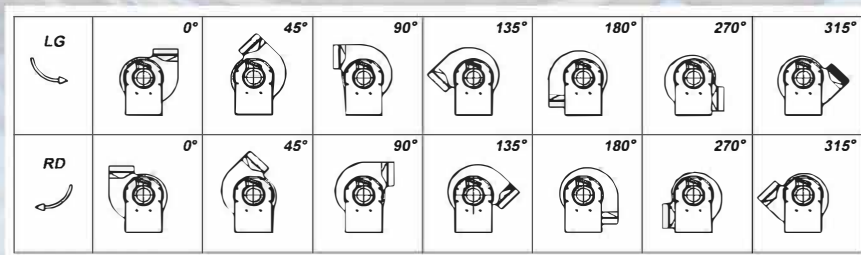

Venplast srl

P 35

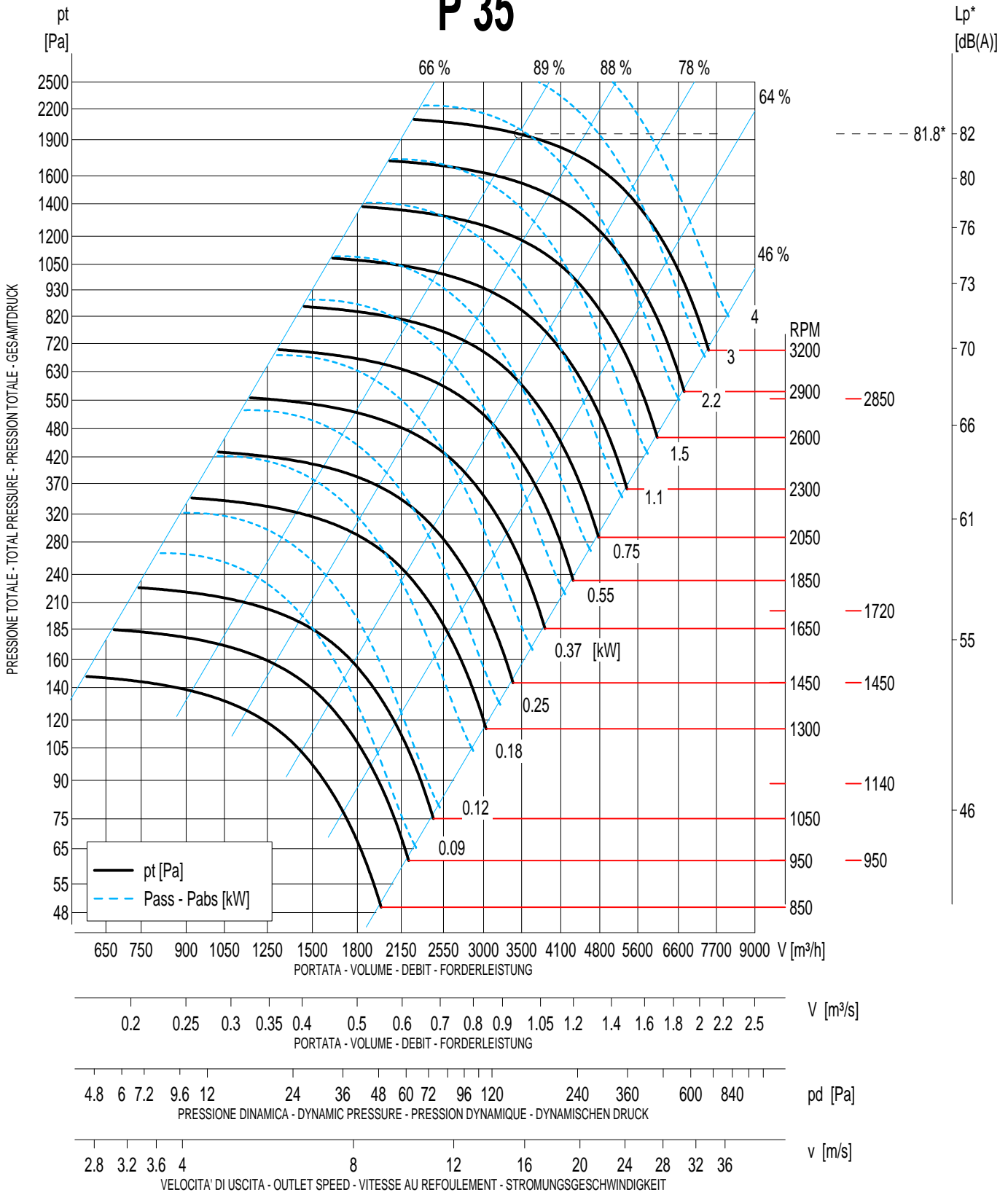

Livello potenza sonora totale - Total sound power level - Gesamt schalleistungspegel - Niveau totale de puissance sonore - [dB] *									
RPM	Banda d'ottava - Octave band - Oktav-Band - Bande d'octave [Hz]								Lp* dB(A)
	63	125	250	500	1000	2000	4000	8000	
900	66.7	71.7	66.7	64.7	63.7	58.7	50.7	42.7	52.9
1140	71.9	76.9	71.9	69.9	68.9	63.9	55.9	47.9	57.9
1450	77.2	79.2	80.2	75.2	74.2	69.2	61.2	53.2	64
2850	92.2	94.2	92.2	93.2	89.2	84.2	76.2	68.2	79.7
3420	96.2	98.2	96.2	97.2	93.2	88.2	80.2	72.2	83.7

(*) Al massimo rendimento - At max. efficiency - (Distanza-distance-abstand-distance : 1.5 [m])

Temperatura - Temperature - Temperatur - Température : 15 [°] - Densità - Density - Bezugsdichte - Densité : 1.225 [kg/m³]

Tolleranza sulla portata ±5% - Capacity tolerance ±5% - Tolérance sur le débit ±5% - Fördertoleranz ±5%

I valori relativi alla rumorosità sono riferiti ad una misurazione in campo libero, con una tolleranza di +3 dB(A)

Noise values refer to a free field measurement with a tolerance of +3 dB(A)

Les valeurs relatives à la bruyance se réfèrent à un mesurage en champ libre, avec une tolérance de +3 dB(A)

Die die Geräuschentwicklung betreffenden Werte beziehen sich auf eine Freifeld-Messung bei einer Toleranz von +3 dB(A)

PD² - WD² - GD² - PD² : 0.045 kgm²

Serie P-40

Serie di ventilatori a pale rovesce.

Versioni:

Standard: coclea stampata Pe - girante PP - supporto motore in lamiera di acciaio verniciato polveri - viteria acciaio INOX

ATEX: coclea stampata Pe-el conduttivo - girante PP - supporto motore in lamiera di acciaio verniciato polveri - viteria acciaio INOX

Fans series with backward curved blades.

Versions:

Standard: Pe moulded housing - PP impeller - epoxy painted motor support - stainless steel screws

ATEX: Pe-el antistatic housing - PP impeller - epoxy painted motor support - stainless steel screws

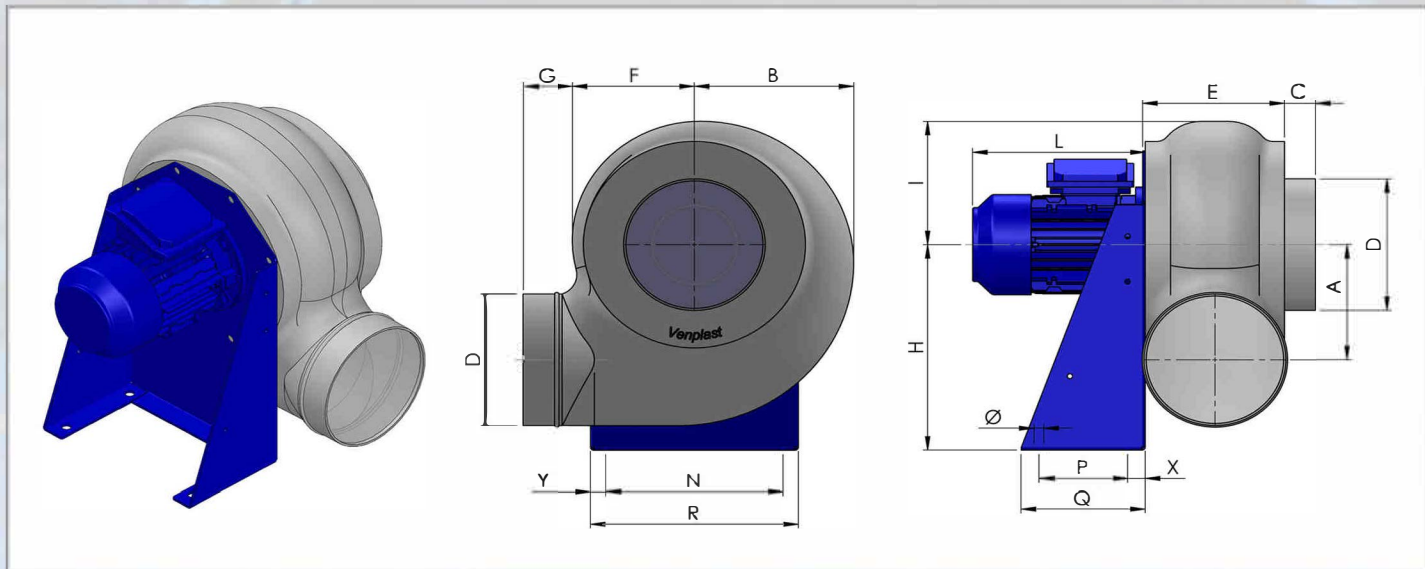

Tipo Type	Mot.Gr. Size	Mot. Kw	Giri Rpm	A	B	C	D	E	F	G	H	I	L	N	P	Q	R	Y	X	Ø	KG.*	KG.**
P 204	63	0.12	1370	140	180	35	160	160	138	55	250	150	190	200	100	140	235	17,5	20	11	9	17
P 202	63	0.18	2750	140	180	35	160	160	138	55	250	150	195	200	100	140	235	17,5	20	11	9	17
P 224	63	0.12	1370	173	228	35	200	185	170	55	310	190	190	255	100	140	290	17,5	20	11	10	18
P 222	63	0.25	2800	173	228	35	200	185	170	55	310	190	210	225	100	140	290	17,5	20	11	13	24
P 254	63	0.12	1370	173	228	35	200	185	170	55	310	190	190	255	100	140	290	17,5	20	11	10	18
P 252	71	0.37	2800	173	228	35	200	185	170	55	310	190	220	255	100	140	290	17,5	20	11	13	24
P 284	63	0.18	1370	208	255	40	225	195	190	70	350	210	190	280	120	190	316	18	35	11	14	23
P 282	80	0.75	2850	208	255	40	225	195	190	70	350	210	240	280	120	190	316	18	35	11	19	33
P 316	71	0.18	930	240	280	40	250	200	210	70	410	230	210	320	150	230	355	17,5	40	11	19	30
P 314	71	0.25	1400	240	280	40	250	200	210	70	410	230	220	320	150	230	355	17,5	40	11	19	30
P 312	90	1.50	2850	240	280	40	250	200	210	70	410	230	290	320	150	230	355	17,5	40	11	26	45
P 356	71	0.18	930	260	312	40	280	237	230	55	445	270	210	355	150	230	390	17,5	40	11	23	34
P 354	71	0.37	1400	260	312	40	280	237	230	55	445	270	220	355	150	230	390	17,5	40	11	23	34
P 352	90	2.20	2870	260	312	40	280	237	230	55	445	270	290	355	150	230	390	17,5	40	11	32	51
P 406	71	0.25	920	290	356	40	315	252	264	55	495	295	220	325	170	250	365	20	40	11	30	41
P 404	80	0.55	1410	290	356	40	315	252	264	55	495	295	240	325	170	250	365	20	40	11	33	47
P 456	80	0.37	920	324	400	40	355	287	295	55	550	330	240	370	170	250	410	20	40	11	37	51
P 454	90	1.10	1410	324	400	40	355	287	295	55	550	330	290	370	170	250	410	20	40	11	40	61
P 452	100	4.0	2860	324	400	40	355	287	295	55	550	330	415	370	270	340	410	20	40	11	57	72

* esecuzione con motore standard – standard motor execution

** esecuzione ATEX – ATEX execution

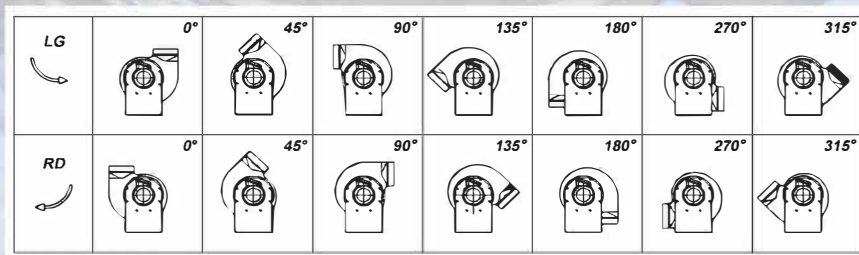

Venplast srl

P 40

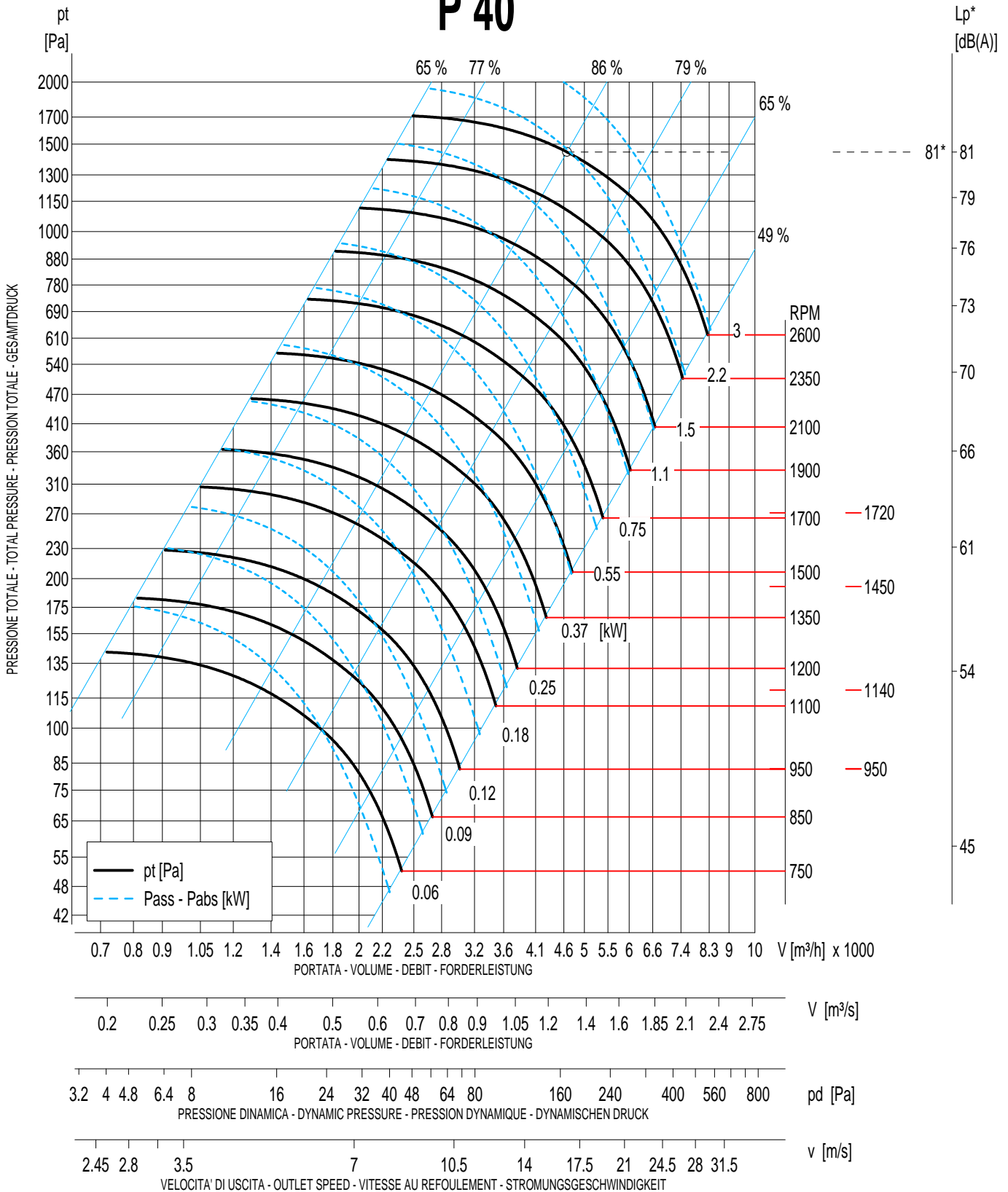

Livello potenza sonora totale - Total sound power level - Gesamt schalleistungspegel - Niveau totale de puissance sonore - [dB] *									
RPM	Banda d'ottava - Octave band - Oktav-Band - Bande d'octave [Hz]								Lp* dB(A)
	63	125	250	500	1000	2000	4000	8000	
750	66.9	71.9	66.9	64.9	63.9	58.9	50.9	42.9	52.9
950	72.1	77.1	72.1	70.1	69.1	64.1	56.1	48.1	58.8
1450	81.5	83.5	84.5	79.5	78.5	73.5	65.5	57.5	68
1720	85.3	87.3	88.3	83.3	82.3	77.3	69.3	61.3	72
2100	89.7	91.7	92.7	87.7	86.7	81.7	73.7	65.7	76.1

(*) Al massimo rendimento - At max. efficiency - (Distanza-distance-abstand-distance : 1.5 [m])

Temperatura - Temperature - Temperatur - Température : 15 [°] - Densità - Density - Bezugsdichte - Densité : 1.225 [kg/m³]

Tolleranza sulla portata ±5% - Capacity tolerance ±5% - Tolérance sur le débit ±5% - Fördertoleranz ±5%

I valori relativi alla rumorosità sono riferiti ad una misurazione in campo libero, con una tolleranza di +3 dB(A)

Noise values refer to a free field measurement with a tolerance of +3 dB(A)

Les valeurs relatives à la bruyance se réfèrent à un mesurage en champ libre, avec une tolérance de +3 dB(A)

Die die Geräuschentwicklung betreffenden Werte beziehen sich auf eine Freifeld-Messung bei einer Toleranz von +3 dB(A)

PD² - WD² - GD² - PD² : 0.077 kgm²

Serie P-45

Serie di ventilatori a pale rovesce.

Versioni:

Standard: coclea stampata Pe - girante PP - supporto motore in lamiera di acciaio verniciato polveri - viteria acciaio INOX

ATEX: coclea stampata Pe-el conduttivo - girante PP - supporto motore in lamiera di acciaio verniciato polveri - viteria acciaio INOX

Fans series with backward curved blades.

Versions:

Standard: Pe moulded housing - PP impeller - epoxy painted motor support - stainless steel screws

ATEX: Pe-el antistatic housing - PP impeller - epoxy painted motor support - stainless steel screws

Esecuzione 5
Arrangement 5

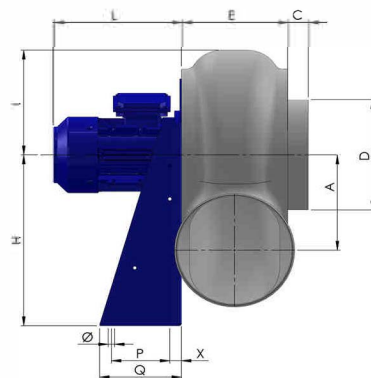
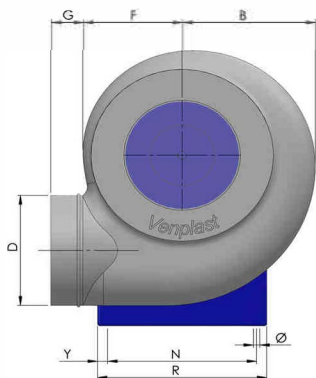
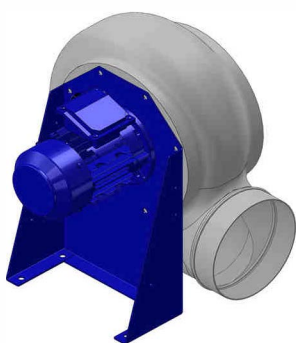

Esecuzione 4
Arrangement 4

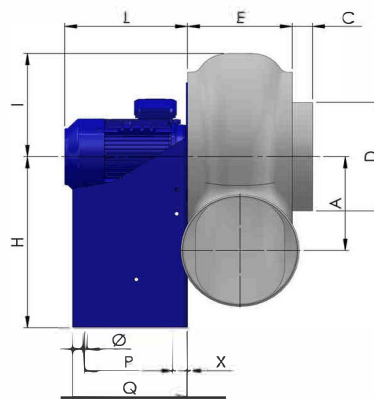
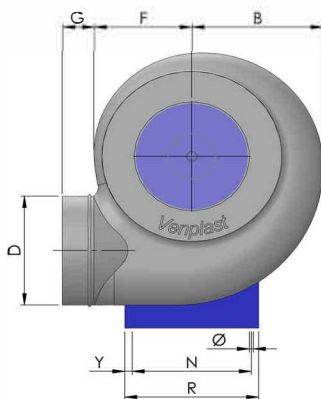
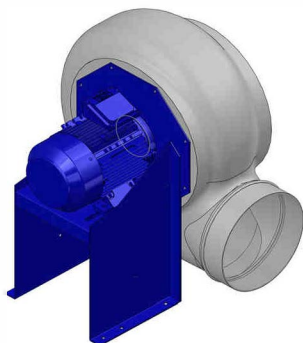

	Tipo	Mot.Gr.	Mot.	Giri	A	B	C	D	E	F	G	H	I	L	N	P	Q	R	Y	X	Ø	KG.*	KG.**
	Type	Size	Kw	Rpm																			
Es.5 Arr.5	P 456	80	0.37	920	324	400	40	355	287	295	55	550	330	240	370	170	250	410	20	40	11	37	51
	P 454	90	1.10	1410	324	400	40	355	287	395	55	550	330	290	370	170	250	410	20	40	11	40	61
Es.4 Arr.4	P 452	100	4.0	2860	324	400	40	355	287	295	55	550	330	415	370	270	340	410	20	40	11	57	72

* esecuzione con motore standard - standard motor execution

** esecuzione ATEX - ATEX execution

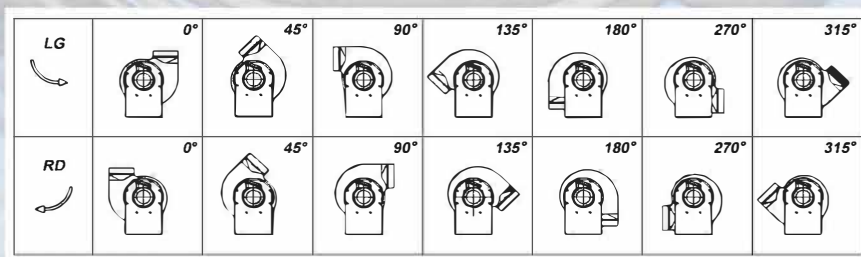

Venplast srl

P 45

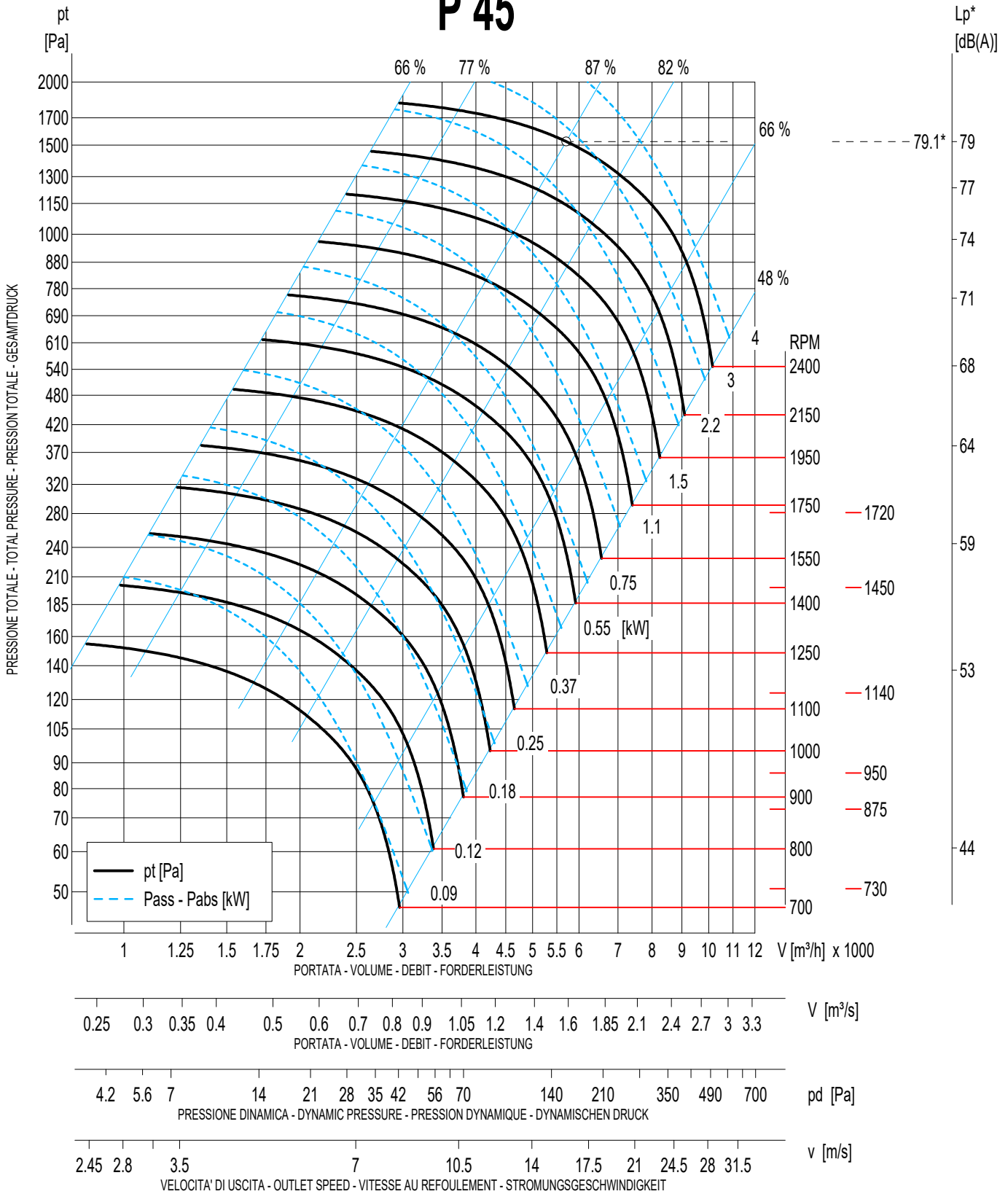

Livello potenza sonora totale - Total sound power level - Gesamt schalleistungspegel - Niveau totale de puissance sonore - [dB] *									
RPM	Banda d'ottava - Octave band - Oktav-Band - Bande d'octave [Hz]								Lp* dB(A)
	63	125	250	500	1000	2000	4000	8000	
750	67	72	67	65	64	59	51	43	52.9
950	72.3	77.3	72.3	70.3	69.3	64.3	56.3	48.3	58.8
1450	81.6	83.6	84.6	79.6	78.6	73.6	65.6	57.6	68.1
1720	85.4	87.4	88.4	83.4	82.4	77.4	69.4	61.4	72
2000	88.8	90.8	91.8	86.8	85.8	80.8	72.8	64.8	75.1

(*) Al massimo rendimento - At max. efficiency - (Distanza-distance-abstand-distance : 1.5 [m])

Temperatura - Temperature - Temperatur - Température : 15 [°] - Densità - Density - Bezugsdichte - Densité : 1.225 [kg/m³]

Tolleranza sulla portata ±5% - Capacity tolerance ±5% - Tolérance sur le débit ±5% - Fördertoleranz ±5%

I valori relativi alla rumorosità sono riferiti ad una misurazione in campo libero, con una tolleranza di +3 dB(A)

Noise values refer to a free field measurement with a tolerance of +3 dB(A)

Les valeurs relatives à la bruyance se réfèrent à un mesurage en champ libre, avec une tolérance de +3 dB(A)

Die die Geräuschentwicklung betreffenden Werte beziehen sich auf eine Freifeld-Messung bei einer Toleranz von +3 dB(A)

PD² - WD² - GD² - PD² : 0.128 kgm²

Serie **P-45/2**

Serie di ventilatori a pale rovesce.

Versioni:

Standard: coclea stampata Pe - girante PP - supporto motore in lamiera di acciaio verniciato polveri - viteria acciaio INOX

ATEX: coclea stampata Pe-el conduttivo - girante PP - supporto motore in lamiera di acciaio verniciato polveri - viteria acciaio INOX

Fans series with backward curved blades.

Versions:

Standard: Pe moulded housing - PP impeller - epoxy painted motor support - stainless steel screws

ATEX: Pe-el antistatic housing - PP impeller - epoxy painted motor support - stainless steel screws

Esecuzione 5
Arrangement 5

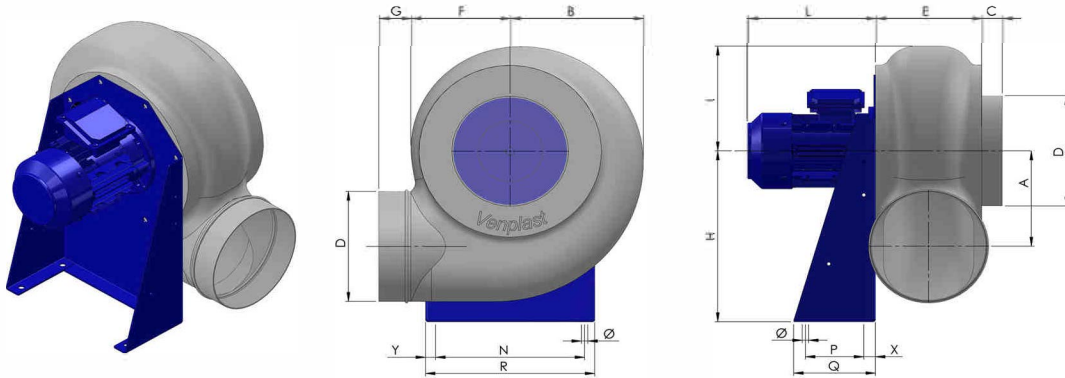

Esecuzione 4
Arrangement 4

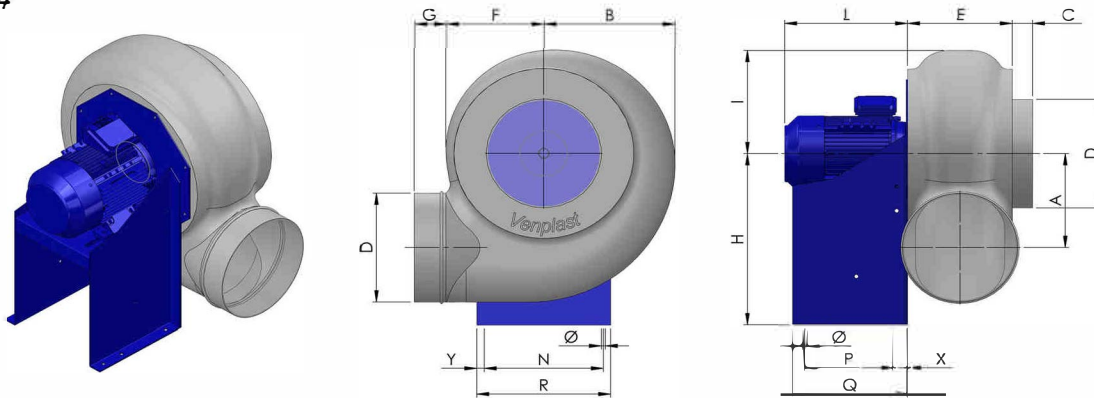

	Tipo	Mot.Gr.	Mot.	Giri	A	B	C	D	E	F	G	H	I	L	N	P	Q	R	Y	X	Ø	KG.*	KG.**
	Type	Size	Kw	Rpm																			
Es.5 Arr.5	P 456	80	0.37	920	324	400	40	355	287	295	55	550	330	240	370	170	250	410	20	40	11	37	51
	P 454	90	1.10	1410	324	400	40	355	287	395	55	550	330	290	370	170	250	410	20	40	11	40	61
Es.4 Arr.4	P 452	100	4.0	2860	324	400	40	355	287	295	55	550	330	415	370	270	340	410	20	40	11	57	72

* esecuzione con motore standard – standard motor execution

** esecuzione ATEX – ATEX execution

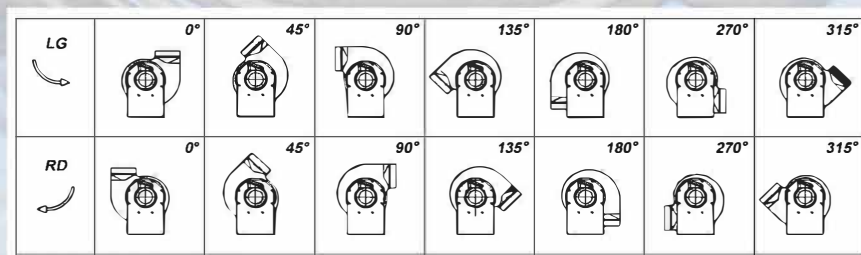

Venplast srl

P 45-2

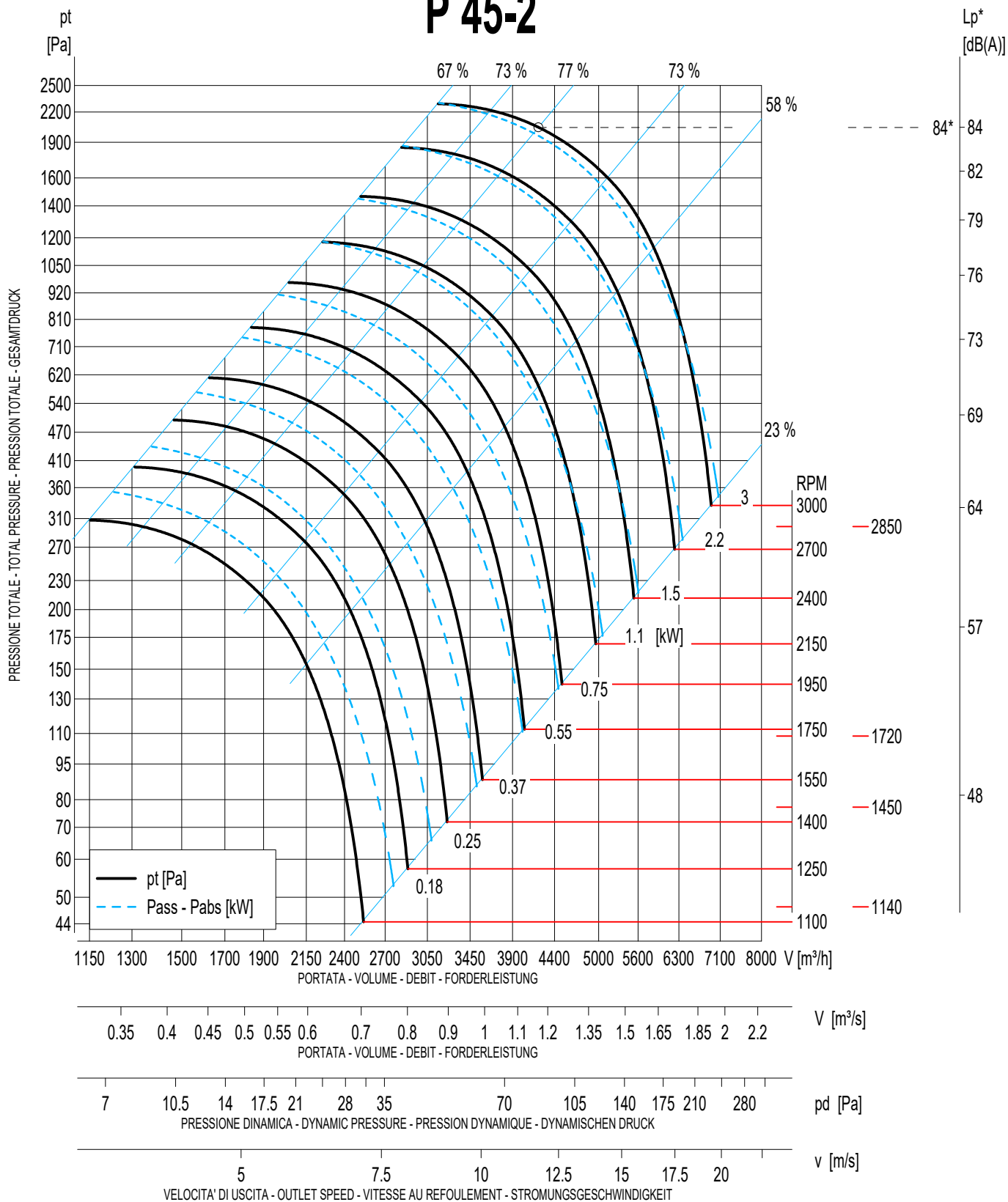

Livello potenza sonora totale - Total sound power level - Gesamt schalleistungspegel - Niveau totale de puissance sonore - [dB] *									
RPM	Banda d'ottava - Octave band - Oktav-Band - Bande d'octave [Hz]								Lp* dB(A)
	63	125	250	500	1000	2000	4000	8000	
1100	75.3	80.3	75.3	73.3	72.3	67.3	59.3	51.3	61.8
1550	82.9	87.9	82.9	80.9	79.9	74.9	66.9	58.9	68.9
2150	90.1	92.1	93.1	88.1	87.1	82.1	74.1	66.1	77
2500	93.5	95.5	96.5	91.5	90.5	85.5	77.5	69.5	80
3000	97.5	99.5	100.5	95.5	94.5	89.5	81.5	73.5	84

(*) Al massimo rendimento - At max. efficiency - (Distanza-distance-abstand-distance : 1.5 [m])

Temperatura - Temperature - Temperatur - Température : 15 [°] - Densità - Density - Bezugsdichte - Densité : 1.225 [kg/m³]

Tolleranza sulla portata ±5% - Capacity tolerance ±5% - Tolérance sur le débit ±5% - Fördertoleranz ±5%

I valori relativi alla rumorosità sono riferiti ad una misurazione in campo libero, con una tolleranza di +3 dB(A)

Noise values refer to a free field measurement with a tolerance of +3 dB(A)

Les valeurs relatives à la bruyance se réfèrent à un mesurage en champ libre, avec une tolérance de +3 dB(A)

Die die Geräuschentwicklung betreffenden Werte beziehen sich auf eine Freifeld-Messung bei einer Toleranz von +3 dB(A)

PD² - WD² - GD² - PD² : 0.128 kgm²

14/07/2014