

**AAVA**



**HIGH PRESSURE WITH BACKWARD IMPELLER**

**MANUFACTURING FEATURES:**

- Fan made of Fe360 sheet. The fan paint finish is based on a Qualicoat polyester powder coating stoved at 200°C, with an average film thickness of 70 microns. Average heat resistance of coating is 180°C with peaks of 200°C.
- Fully welded housing.
- High efficiency simple inlet backward impeller with self-cleaning system made of Fe360 sheet statically and dynamically balanced. Impellers are painted with polyester primer that resists temperatures up to 300°C.
- Standard asynchronous squirrel-cage motor with IP-55 protection and class F insulation. Manufactured with standard voltages: 230/400V 50Hz in three phase motors up to 4kW and 400/690V 50Hz for higher powers.
- Standard orientation LG270.
- It allows adjusting the orientation locally from models 220 to 630. Models sizes from 710 to 1000 size the orientation is fixed.

**APPLICATIONS:**

- Designed for inline installation, they are suitable for:
- Industrial applications, extraction or injection of air.
  - Cooling of machines and parts.
  - Clean air transport.
  - Exhaust after filters, separators and cyclones.
  - Pneumatic transport.
  - Maximum working temperature: carried air: 130°C, ambient: 60°C.

**UNDER REQUEST**

- Fans for 60Hz and special voltages.
- 2 speed motor.
- C4 or C5 coating painting
- Hot dip galvanized
- Special steel (Cor-Ten A, Hardox...)
- Inox 304 (normal or electropolished finish)
- Inox 316 (normal or electropolished finish)
- Cooling wheel
- Anticaloric paint
- Reinforced housing
- Fully welded housing (waterproof)
- Insulated housing
- Split casing (for big sizes)
- Inspection door to facilitate maintenance and cleaning
- Drain plug.
- Airtight axle
- Frontal foot
- Double suction flange
- Available in non-sparking air passage and standard motor.
- Other brands of motors.
- Orientation: RD0, RD45, RD90, RD135, RD180, RD225, RD270, RD315, LG0, LG45, LG90, LG135, LG180. LG225, LG315.

**Accessories**



**AB**



**AC**



**AVR**



**AVS**



**BA-400**



**BAD**



**EI**



**FS**



**INT**



**JE 45**



**RA**



**RI**



**SFC**

## Technical data

### Three-phase motor / 2 poles

Code	Model	R.P.M.	Rated I. (A) 400V	Rated power kW	Max. Airflow m <sup>3</sup> /h	Sound db (A)**	Weight	Connect. diagram
502403114	AAVA 310/P T2 0,25kW	2800	0,65	0,25	120	58	29	1
502403515	AAVA 350/P T2 0,37kW	2800	0,91	0,37	190	59	33	1
502404016	AAVA 400/P T2 0,55kW	2800	1,29	0,55	260	62	44	1
502404517	AAVA 450/P T2 0,75kW	2800	1,58	0,75	330	64	46	1
502405018	AAVA 500/P T2 1,1kW	2800	2,33	1,1	330	66	51	1
502405619	AAVA 560/P T2 1,5kW	2865	3,14	1,5	370	68	89	1
502406319	AAVA 631/P T2 1,5kW	2865	3,14	1,5	330	69	116	1
502406327	AAVA 632/P T2 2,2kW	2840	4,58	2,2	400	70	119	1
502407129	AAVA 711/P T2 3kW	2880	5,92	3	480	72	149	1
502407132	AAVA 712/P T2 4kW	2880	7,63	4	550	73	168	1
502408032	AAVA 801/P T2 4kW	2880	7,63	4	480	75	195	1
502408034	AAVA 802/P T2 5,5kW	2910	10,6	5,5	550	77	197	1
502408036	AAVA 803/P T2 7,5kW	2910	14,1	7,5	730	79	197	1
502409021	AAVA 901/P T2 11kW	2940	20,8	11	870	81	330	1
502409024	AAVA 902/P T2 15kW	2935	27,4	15	1.230	83	390	1
502410026	AAVA 1001/P T2 18,5kW	2940	34,4	18,5	1.450	85	442	1
502410028	AAVA 1002/P T2 22kW	2940	39,8	22	1.640	87	501	1

**Notes:**

\*\* Total sound pressure level at the point of maximum flow measured in dB(A) in the suction measured in free field at a distance of 6m from the source

## Dimensions

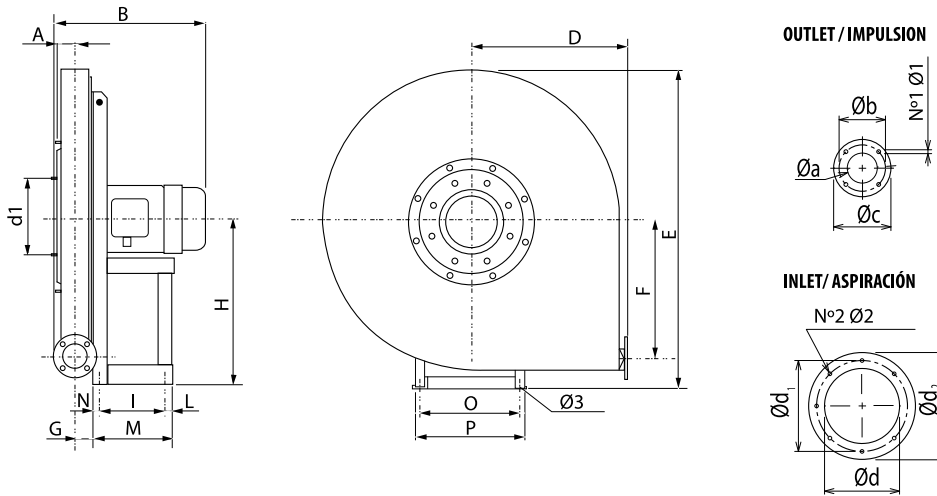

Model	A	B	D	E	F	G	H	I	L
AAVA 310/P T2 0,25kW	34	280	270	550	220	30	280	86	14
AAVA 350/P T2 0,37kW	34	310	270	550	220	30	280	121	23
AAVA 400/P T2 0,55kW	34	310	350	705	300	31	355	121	23
AAVA 450/P T2 0,75kW	34	335	350	705	300	31	355	121	45
AAVA 500/P T2 1,1kW	34	335	350	705	300	31	355	121	45
AAVA 560/P T2 1,5kW	34	380	405	830	355	32	425	133	58
AAVA 631/P T2 1,5kW	34	380	405	830	355	32	425	133	58
AAVA 632/P T2 2,2kW	34	380	405	830	355	32	425	133	58
AAVA 711/P T2 3kW	40	440	455	930	400	38	475	197	49
AAVA 712/P T2 4kW	40	460	455	930	400	38	475	197	49
AAVA 801/P T2 4kW	40	460	505	1035	450	38	530	197	49
AAVA 802/P T2 5,5kW	40	460	505	1035	450	38	530	197	49
AAVA 803/P T2 7,5kW	40	460	505	1035	450	38	530	197	49
AAVA 901/P T2 11kW	49	610	570	1170	500	48	600	337	49
AAVA 902/P T2 15kW	49	610	570	1170	500	48	600	337	49
AAVA 1001/P T2 18,5kW	49	610	635	1305	560	48	670	337	49
AAVA 1002/P T2 22kW	49	610	635	1305	560	48	670	337	49

Model	M	N	N1xØ1	N2xØ2	O	P	Ø3	Øa	Øb
AAVA 310/P T2 0,25kW	145	45	4x8,5	Nº8 M6x20	184	206	10	54	84
AAVA 350/P T2 0,37kW	189	45	4x8,5	Nº8 M6x20	203	225	10	54	84
AAVA 400/P T2 0,55kW	189	45	4x8,5	Nº8 M6x20	203	225	10	54	84

Model	M	N	N1xØ1	N2xØ2	O	P	Ø3	Øa	Øb
AAVA 450/P T2 0,75kW	211	45	4x8,5	Nº8 M6x20	203	225	10	54	84
AAVA 500/P T2 1,1kW	211	45	4x8,5	Nº8 M6x20	203	225	10	54	84
AAVA 560/P T2 1,5kW	246	55	4x8,5	Nº8 M6x20	246	260	10	54	84
AAVA 631/P T2 1,5kW	246	55	4x8,5	Nº8 M6x20	234	260	10	54	84
AAVA 632/P T2 2,2kW	246	55	4x8,5	Nº8 M6x20	234	260	10	54	84
AAVA 711/P T2 3kW	276	30	4x8,5	Nº8 M6x20	289	324	12	66	102
AAVA 712/P T2 4kW	276	30	4x8,5	Nº8 M6x20	289	324	12	66	102
AAVA 801/P T2 4kW	276	30	4x8,5	Nº8 M6x20	289	324	12	66	102
AAVA 802/P T2 5,5kW	276	30	4x8,5	Nº8 M6x20	289	324	12	66	102
AAVA 803/P T2 7,5kW	276	30	4x8,5	Nº8 M6x20	289	324	12	66	102
AAVA 901/P T2 11kW	436	50	4x8,5	Nº8 M6x20	395	440	14	83	118
AAVA 902/P T2 15kW	436	50	4x8,5	Nº8 M6x20	395	440	14	83	118
AAVA 1001/P T2 18,5kW	436	50	4x8,5	Nº8 M6x20	395	440	14	83	118
AAVA 1002/P T2 22kW	436	50	4x8,5	Nº8 M6x20	395	440	14	83	118

Model	Øc	Ød	Ød1	Ød2
AAVA 310/P T2 0,25kW	104	145	182	215
AAVA 350/P T2 0,37kW	104	145	182	215
AAVA 400/P T2 0,55kW	104	145	182	215
AAVA 450/P T2 0,75kW	104	145	182	215
AAVA 500/P T2 1,1kW	104	145	182	215
AAVA 560/P T2 1,5kW	104	145	182	215
AAVA 631/P T2 1,5kW	104	145	182	215
AAVA 632/P T2 2,2kW	104	145	182	215
AAVA 711/P T2 3kW	126	165	200	235
AAVA 712/P T2 4kW	126	165	200	235
AAVA 801/P T2 4kW	126	165	200	235
AAVA 802/P T2 5,5kW	126	165	200	235
AAVA 803/P T2 7,5kW	126	165	200	235
AAVA 901/P T2 11kW	143	185	219	250

Model	Øc	Ød	Ød1	Ød2
AAVA 902/P T2 15kW	143	185	219	250
AAVA 1001/P T2 18,5kW	143	185	219	250
AAVA 1002/P T2 22kW	143	185	219	250

# Wiring diagram

DIAGRAM N° 1

230/400V

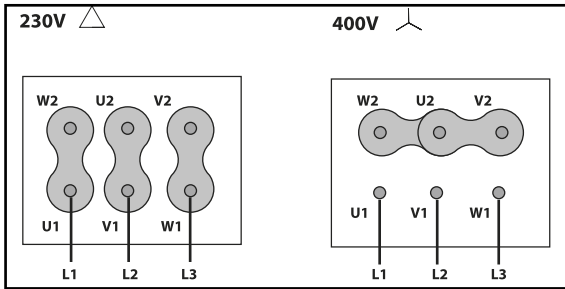

400/690V

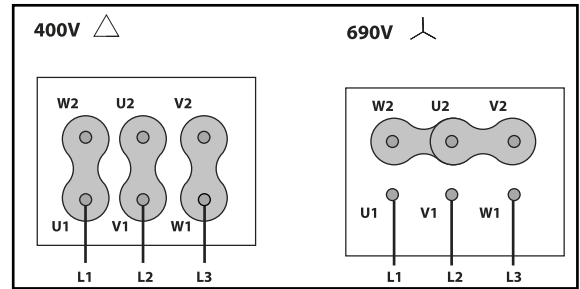

# CHARACTERISTIC CURVE

1	AAVA 310/P T2 0,25kW	2	AAVA 350/P T2 0,37kW	3	AAVA 400/P T2 0,55kW	4	AAVA 450/P T2 0,75kW
5	AAVA 500/P T2 1,1kW	6	AAVA 560/P T2 1,5kW	7	AAVA 631/P T2 1,5kW	8	AAVA 632/P T2 2,2kW
9	AAVA 711/P T2 3kW						

## AIR FLOW - PRESSURE

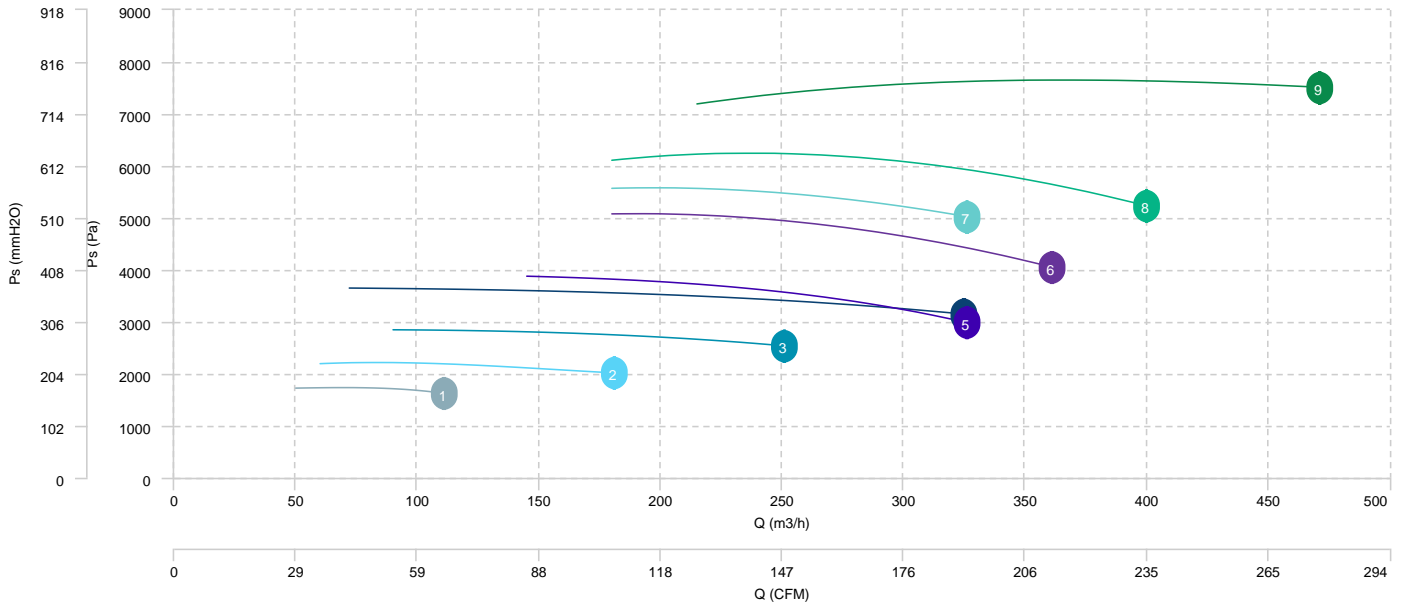

## AIR FLOW - ABSORBED POWER

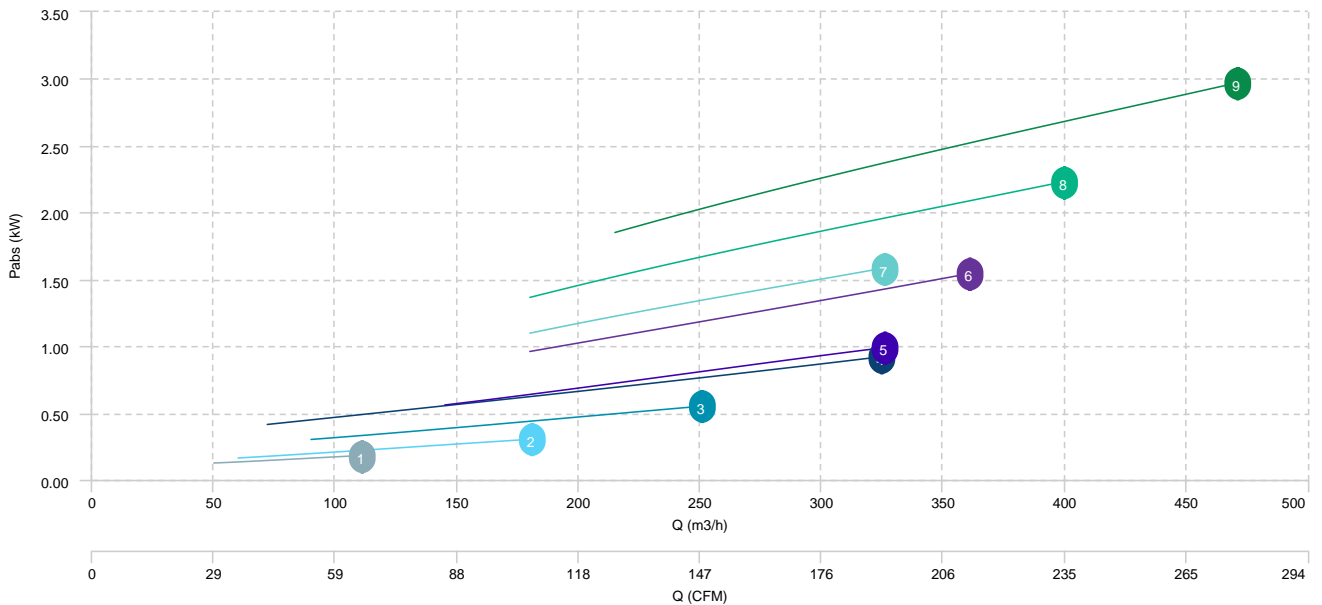

1	AAVA 712/P T2 4kW	2	AAVA 801/P T2 4kW	3	AAVA 802/P T2 5,5kW	4	AAVA 803/P T2 7,5kW
5	AAVA 901/P T2 11kW	6	AAVA 902/P T2 15kW	7	AAVA 1001/P T2 18,5kW	8	AAVA 1002/P T2 22kW

## AIR FLOW - PRESSURE

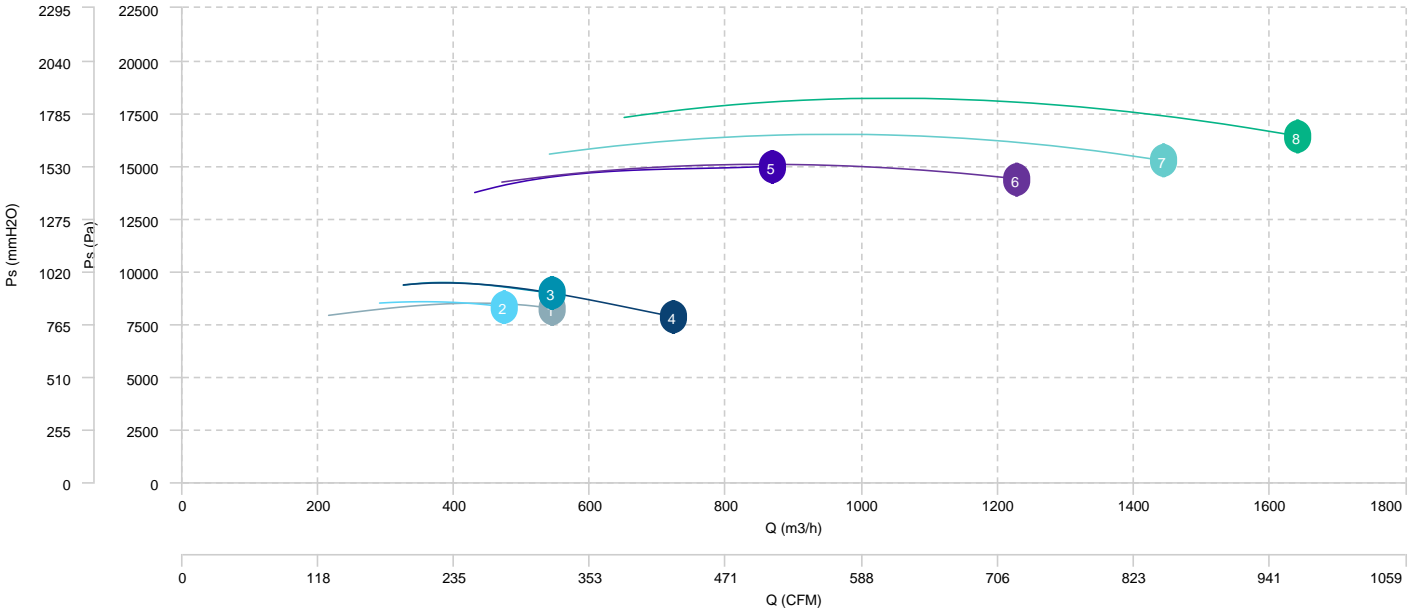

## AIR FLOW - ABSORBED POWER

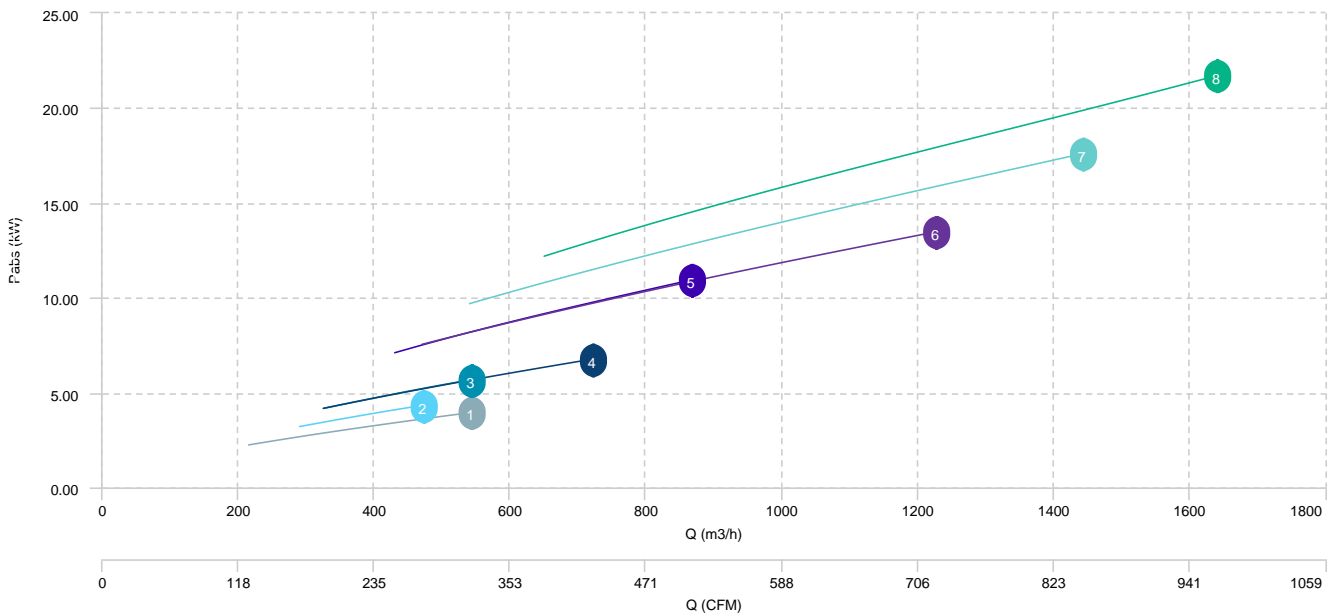



## Sound data

### Sound / 2 poles

Sound power Lw dB (A)										
Model		63 Hz	125 Hz	250 Hz	500 Hz	1000 Hz	2000 Hz	4000 Hz	8000 Hz	Total
AAVA 310/P T2 0,25kW	Inlet	47	62	70	78	79	78	70	71	84
AAVA 350/P T2 0,37kW	Inlet	49	63	72	80	81	80	72	72	85
AAVA 400/P T2 0,55kW	Inlet	51	65	74	82	83	82	74	75	88
AAVA 450/P T2 0,75kW	Inlet	53	67	76	84	85	84	76	76	90
AAVA 500/P T2 1,1kW	Inlet	55	70	78	86	87	86	78	79	92
AAVA 560/P T2 1,5kW	Inlet	57	72	80	88	89	88	80	81	94
AAVA 631/P T2 1,5kW	Inlet	58	73	81	89	90	89	81	82	95
AAVA 632/P T2 2,2kW	Inlet	59	74	82	90	91	90	82	83	96
AAVA 711/P T2 3kW	Inlet	61	76	84	92	93	92	84	85	98
AAVA 712/P T2 4kW	Inlet	63	77	85	93	95	93	85	86	99
AAVA 801/P T2 4kW	Inlet	65	79	88	96	97	95	87	88	101
AAVA 802/P T2 5,5kW	Inlet	67	81	90	98	99	97	90	90	103
AAVA 803/P T2 7,5kW	Inlet	69	83	92	100	101	99	92	92	105
AAVA 901/P T2 11kW	Inlet	70	85	93	101	102	101	93	94	107
AAVA 902/P T2 15kW	Inlet	72	87	95	103	104	103	95	96	109
AAVA 1001/P T2 18,5kW	Inlet	74	89	97	105	106	105	97	98	111
AAVA 1002/P T2 22kW	Inlet	76	91	99	107	108	107	99	100	113

## erp data

ERP	
Fan type	Centrifugal fan backward blades with casing
Installation category	A
Efficiency category	Static
The fan has to be installed with FSC	No

## ERP / 2 poles

Model	Motor power (kW)	Maximum efficiency point data						
		Max. efficiency (%)	Efficiency grade (N) (N)	Air Flow (m <sup>3</sup> /h)	Ps (Pa)	Pabs (kW)	speed (rpm)	Specific ratio
AAVA 310/P T2 0,25kW	0,25	27,58	45,89	110	1.630,64	0,18	2800	1,00
AAVA 350/P T2 0,37kW	0,37	33,43	49,38	180	2.020,45	0,30	2800	1,00