

BVC



MANUFACTURING FEATURES:

- Galvanized steel sheet housing.
- Double inlet forward curved impeller in all models
- Transmission shaft with anticorrosion treatment.
- Supplied with free shaft.
- Transmission shaft standing out on both sides of the fan to allow motor, pulleys and belts assembly.
- Impellers made of polyamide reinforced with fiberglass for sizes 9/9, 10/10 and 12/12; the other models are made of galvanized steel sheet. Ball bearings permanently greased on rubber rings.
- Reinforced cubic assembly with lateral panels and a bearings base plate as well.

APPLICATIONS:

Designed for assembly in equipment:

- Ventilation boxes and air handling units.
- Centrifugal heaters.
- Industrial and professional kitchen hoods.
- Maximum working temperature: 60°C.

Accessories



BS

INT

JE 45

RI

UNDER REQUEST:

- Metallic impeller.

Technical data

Code	Model	Max. Airflow m3/h	Weight
252180180	BVC 9/9	5.820	12
252210180	BVC 10/10	7.460	14
252300180	BVC 12/12	10.450	22
252370180	BVC 15/15	15.150	33
252450180	BVC 18/18	24.510	45

Dimensions

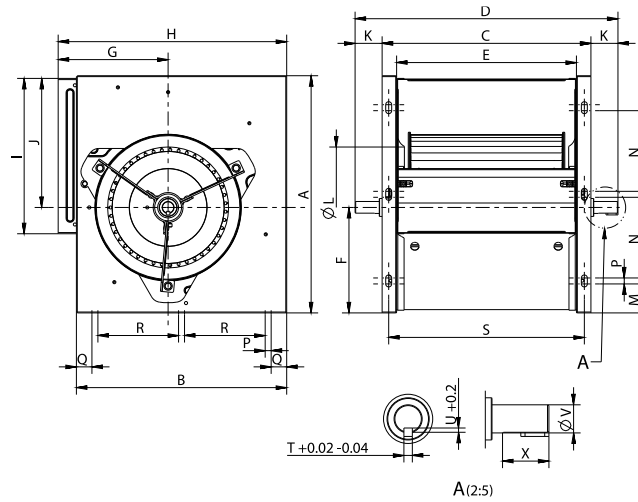

Model	A	B	C	D	E	F	G	H	I
BVC 9/9	397	352	351	440	301	181	184	383	260
BVC 10/10	455	398	380	470	330	205	198	426	291
BVC 12/12	534	468	446	546	396	243	230	497	341
BVC 15/15	628	553	533	630	473	285	271	585	404
BVC 18/18	748	653	616	728	556	335	311	685	483

Model	J	K	LØ	M	N	O	P	Q	R
BVC 9/9	216	45	200	49	135	135	10	30	135
BVC 10/10	250	45	220	61	152	152	10	30	152
BVC 12/12	291	50	260	58	195	195	10	30	195
BVC 15/15	343	49	321	99	200	200	10	60	200
BVC 18/18	413	56	397	109	250	250	10	60	250

Model	S	T	U	V	X
BVC 9/9	329	6	3,5	20	33
BVC 10/10	369	6	3,5	20	33
BVC 12/12	424	8	4	25	46
BVC 15/15	503	8	4	25	52
BVC 18/18	586	8	4	25	52

CHARACTERISTIC CURVE

BVC 9/9

AIR FLOW - PRESSURE

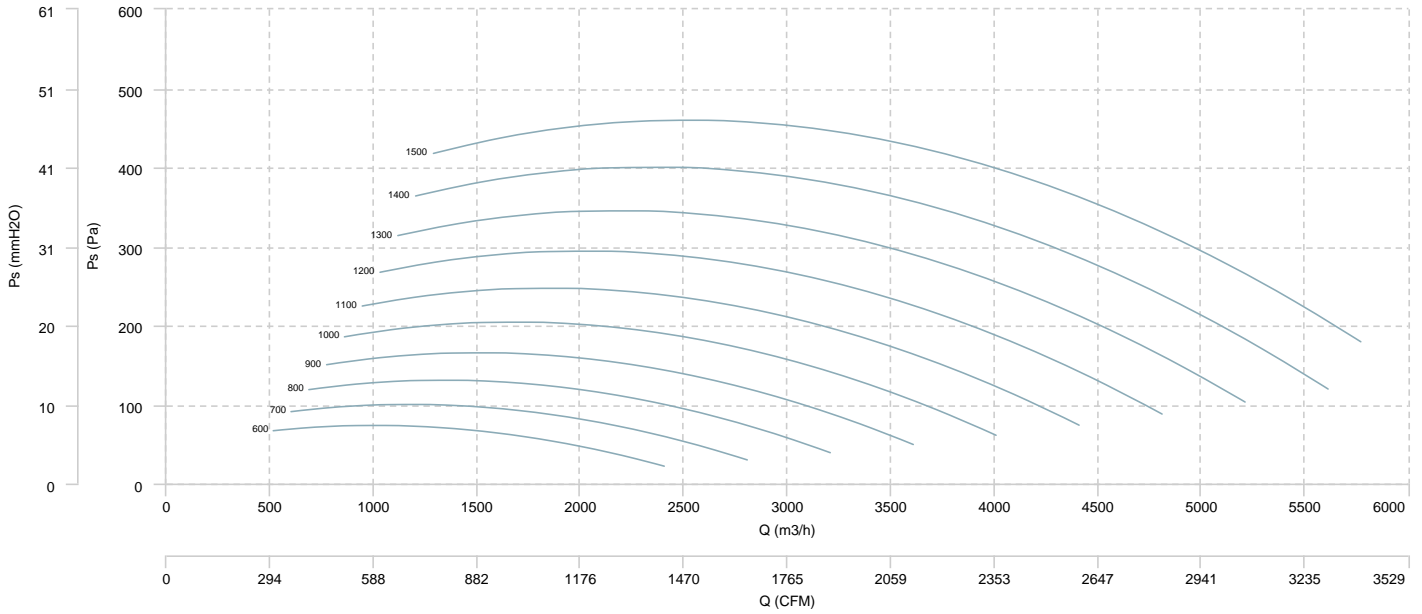

BVC 10/10

AIR FLOW - PRESSURE

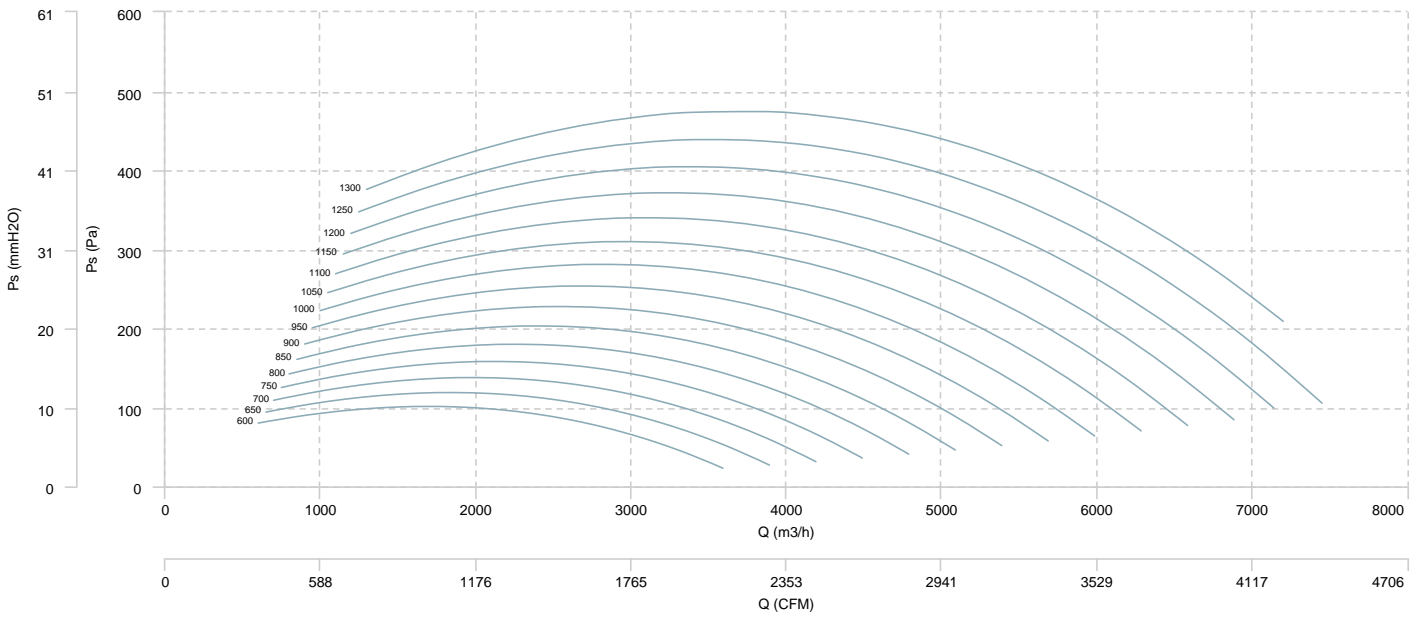

BVC 12/12

AIR FLOW - PRESSURE

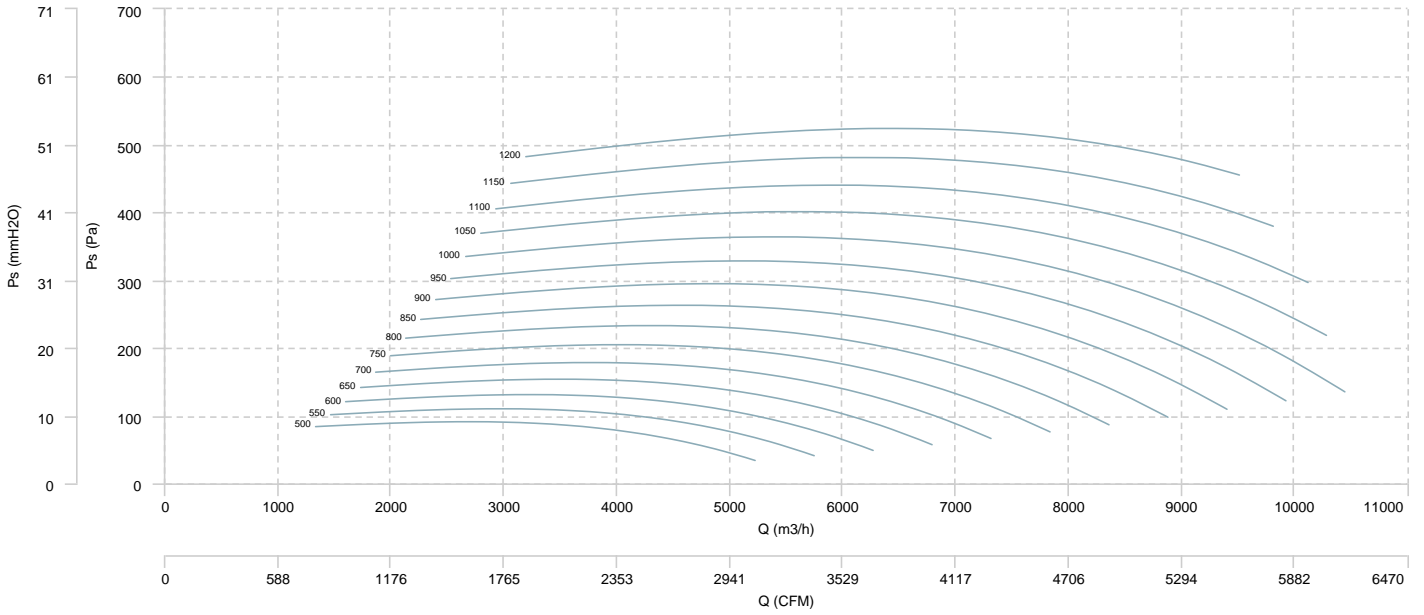

BVC 15/15

AIR FLOW - PRESSURE

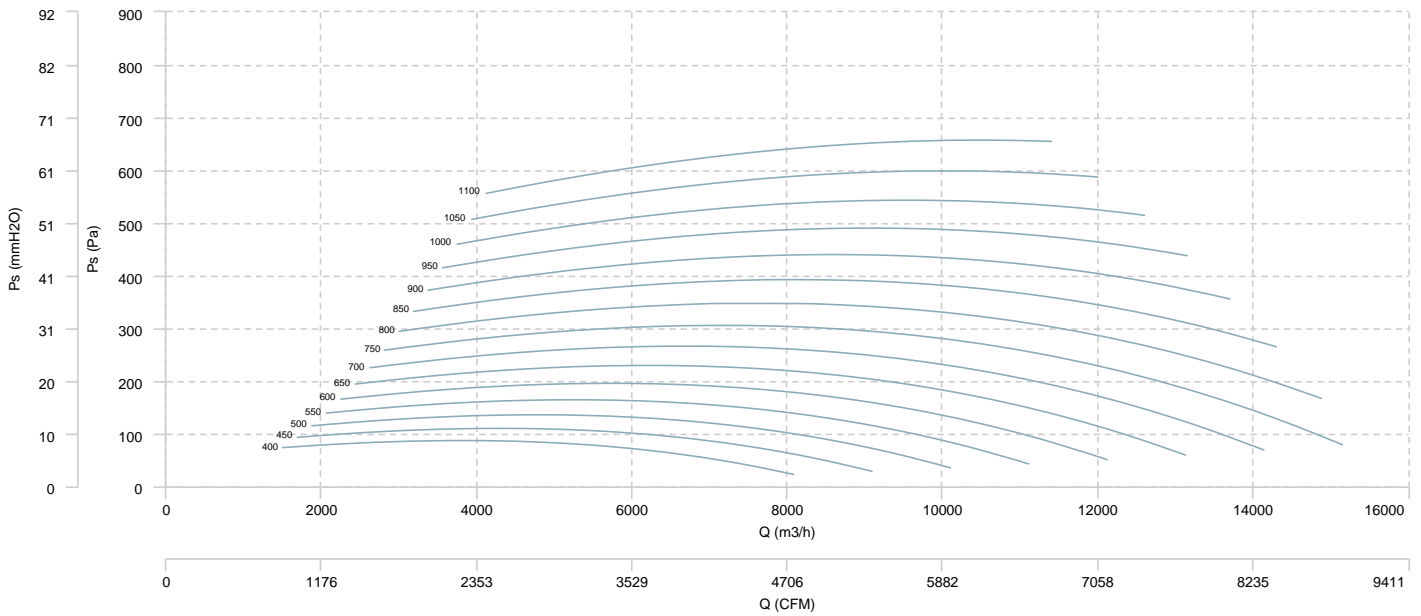

BVC 18/18

AIR FLOW - PRESSURE

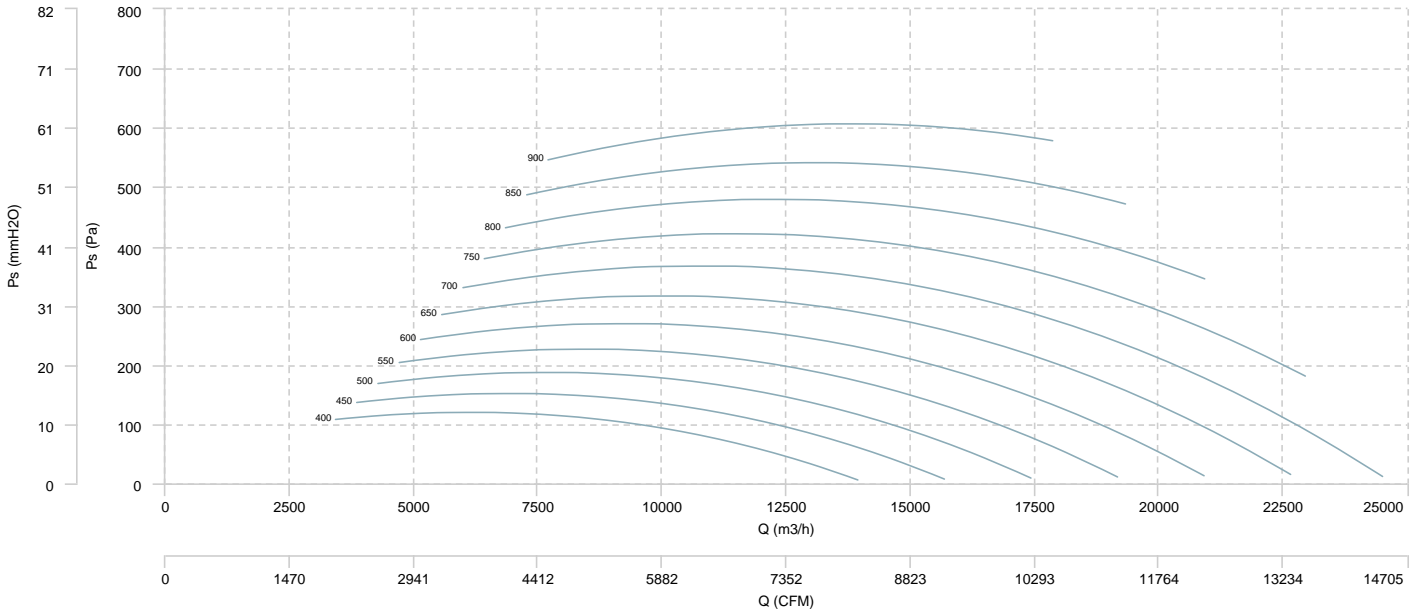

Sound data

Sound power Lw dB (A)										
Model		63 Hz	125 Hz	250 Hz	500 Hz	1000 Hz	2000 Hz	4000 Hz	8000 Hz	Total
BVC 9/9 (600 RPM)	Inlet	46	49	57	60	66	64	61	54	70
BVC 10/10 (600 RPM)	Inlet	44	54	61	66	71	69	66	58	75
BVC 12/12 (500 RPM)	Inlet	46	55	62	68	73	70	67	60	76
BVC 15/15 (400 RPM)	Inlet	50	60	60	66	70	69	65	59	74
BVC 18/18 (400 RPM)	Inlet	53	60	63	71	72	70	67	58	77

Notes:

* To calculate the sound power level at different rpm from those indicated above, use the following formula:

$$Lw\ dB(A)_{rpmA} = Lw\ dB(A)_{rpmB} + 52.5 \cdot \log_{10} \frac{rpmA}{rpmB}$$