

## FOCCETA REG (510117039REG)

### GENERAL DATA



#### FAN FOR BARBECUES WITH DRAUGHT CONTROLLER

This kit is composed of a centrifugal roof extractor fan for fireplaces, stoves and barbecues, together with a REG 1,5 A speed controller to adjust the draught, and a 2 m pre-terminated cable for easy connection.

- **FOCCETA roof extractor:** backward-curved aluminium impeller, up to 750 m<sup>3</sup>/h at 52 dB(A). Continuous duty operation at 200°C. Class I motor, IPX4 with thermal cut-out and ball bearings. Hammer-finish steel cowl, black polyester coating, epoxy base, and welded steel anti-bird guard (according to UNI ISO 13857 standard). Sub-frame for chimney mounting, with stainless steel safety wire to secure the unit once installed.
- **REG 1.5 A manual speed controller:** adjusts draught for ignition, steady cooking, or overnight burning. IP54 sealed enclosure. Switch with pilot light.
- **Pre-terminated cable:** 2 m flexible three-core cable with pin terminals for easy connection from motor to controller. No crimping or soldering required.

#### Applications:

- Fireplaces, stoves, and barbecues.
- Professional-grade extraction with maximum ease of installation.

### PERFORMANCE CURVE

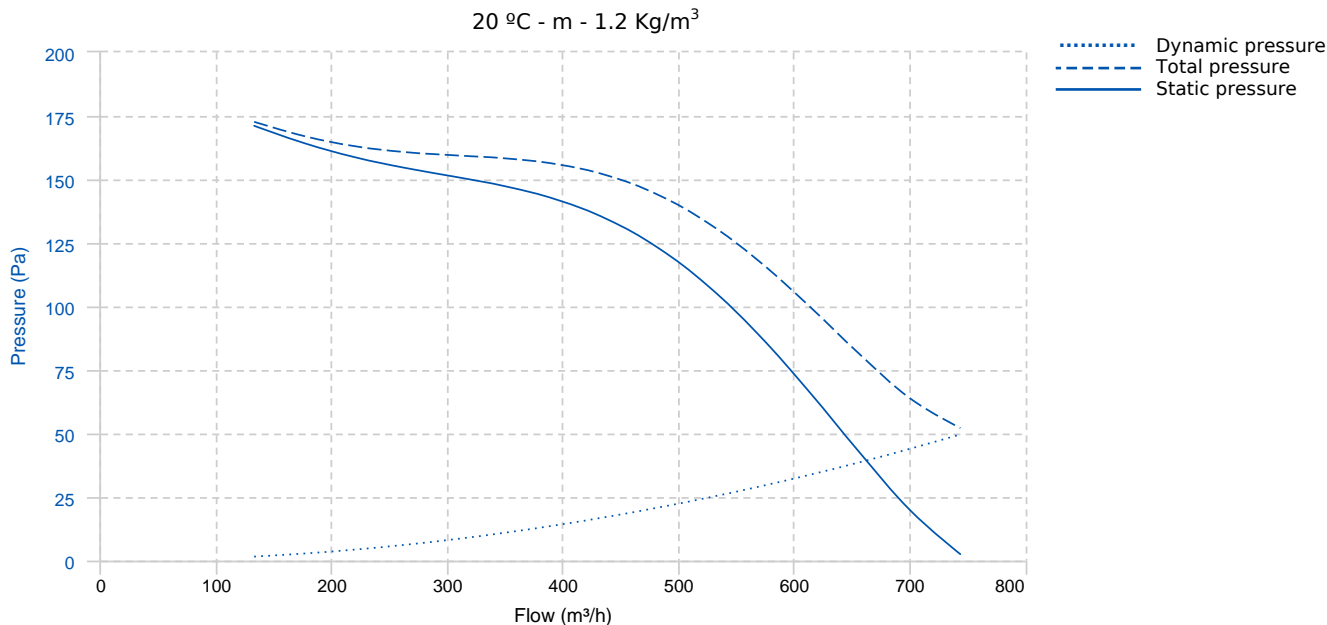

### TECHNICAL DATA

Fan							
RPM	1400	Approx. weight	19 kg	Max. Flow	750 m <sup>3</sup> /h		
Motor							
Power	0,12 kW	RPM	1400	I max. (230V)	0,5 A	Approx. weight	0 kg

**DIMENSIONS**

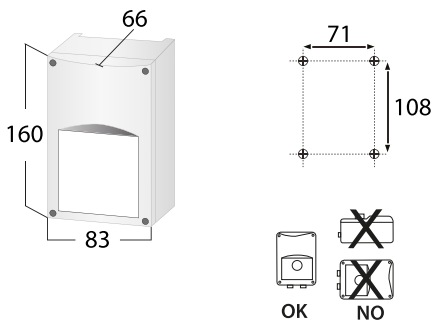
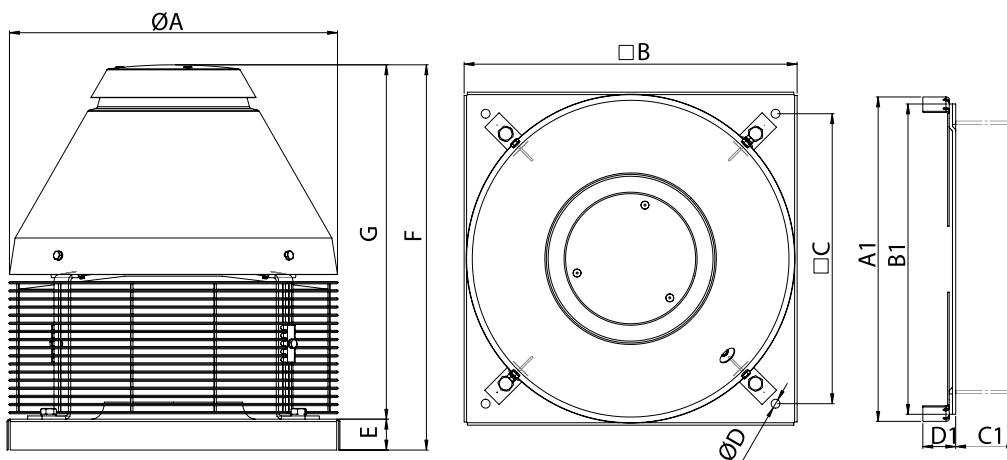

**Dimensions (mm)**

A1	401	B	410	B1	357	C	357	C1	140
D1	40	E	38	F	518	G	480	$\varnothing A$	405
$\varnothing D$	10	$\varnothing$ duct	200	$\varnothing$ inlet	170				

**WIRING DIAGRAM**

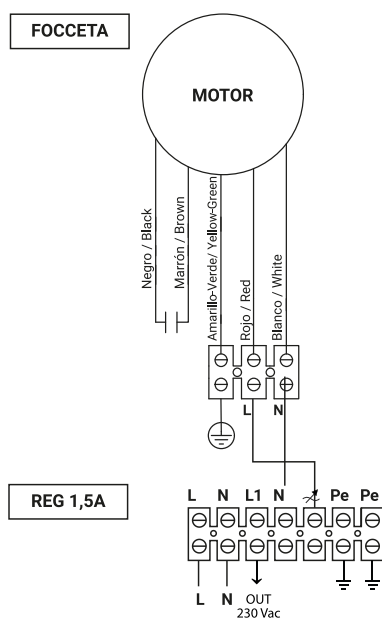

L N	main supply 230 VAC - 50 Hz   alimentación principal 230 VAC-50Hz
N	neutral   neutro
Pe	earth connection   tierra
L1 N	unregulated out 230 VAC (2A)   salida no regulada 230 VAC (2A)
N	regulated output to motor   salida a motor regulada
JP1	jumper removed = normal working mode   puente desconectado = modo normal jumper in place = quickstart mode   puente conectado = modo de arranque rápido
PT1	minimum speed adjustment trimmer   ajuste de velocidad mínima

**ACCESSORIES**



**SAFETY SWITCH**  
**INT 25 3P A**  
**REF: INT253PA**